

REV.	DATE	DCN #	DRAWING TREE #

NOTES CONTINUED:
 ○ SCRIBE, ENGRAVE, OR MECHANICALLY STAMP (NO INKS OR DYES) DRAWING PART NUMBER AND REVISION ON NOTED SURFACE FOLLOWED ON NEXT LINE BY A THREE DIGIT SERIAL NUMBER. SERIAL NUMBERS START AT 001 FOR THE FIRST ANGLE AND PROCEED CONSECUTIVELY. USE 07" HIGH CHARACTERS. EXAMPLE: D100000.VV.5/01.001 VIBRATORY TOOL MAY BE USED.
 A APPROXIMATE WEIGHT - XXXX LB.
 6. MACHINE ALL SURFACES TO REMOVE OXIDES AND MILL FINISH. USE OF ABRASIVE REMOVAL TECHNIQUES IS NOT ALLOWED. REFER TO LIGO E0900364.
 8. ALL PARTS SHALL BE MANUFACTURED IN ACCORDANCE WITH LIGO SPECIFICATION E0900364.
 9. ALL HELI-COIL HOLES TO BE PREPARED ACCORDING TO EMHART HELI-COIL PRODUCT CATALOG, HC2000, REV 4
 10. ALL HELI-COIL INSERTS TO BE INSTALLED BY LIGO PERSONNEL AFTER DELIVERY OF FINISHED PARTS. USE NITRIDING 60 THREADED INSERTS.
 11. ALL MATERIAL IS TO BE VIRGIN MATERIAL (i.e. NO WELD REPAIRS, PLUGS OR RECYCLED MATERIAL). NO REPAIRS SHALL BE MADE UNLESS APPROVED IN ADVANCE, AND IN WRITING, BY LIGO LABORATORY. REFER TO LIGO E0900364.
 12. SURFACE FINISH TO BE AS PROCESSED FROM MILL/SUPPLIER, FREE FROM SCRATCHES OR GOUGES.
 13. PART WILL BE PORCELAIN COATED PER LIGO SPECIFICATION E1000083 AFTER FABRICATION. THE INDICATED HOLES WILL BE MASKED PRIOR TO PORCELAIN COATING TO APPROXIMATELY 2.5-3X HOLE DIAMETER CENTERED ON BOTH SIDES OF THE HOLE.
 14. DIMENSIONS APPLY BEFORE PORCELAIN COATING UNLESS SPECIFIED.
 15. BEND RADIUS: UNLESS OTHERWISE NOTED, THE BEND RADIUS SHOULD BE THE MINIMUM REQUIRED TO FORM WITHOUT CRACKING OR REQUIRING ADDITIONAL WORK WHEN FORMING. IN PARTICULAR IF SHEET METAL IS TO BE PORCELAIN COATED, THE BEND RADIUS SHALL BE A MINIMUM OF 12" OUTSIDE RADIUS OF BEND UNLESS OTHERWISE NOTED.

CONNECTOR J1

ELECTROLESS NICKEL PLATING OVER PEEK

#4-40 THREADED INSERT (x2)

PIN 1

NOT METALIZED NEXT TO PINS

#2-56 x 0.625" (x4) MACHINE SCREW

STANDARD D-SUB 25 PIN MALE MIL-C-24308

CONNECTOR J1

VENT HOLE

CONNECTOR J2

CONNECTOR J3

NON-METALIZED PEEK

48in. [1219.2mm]
NOT TO SCALE

#4-40 x 0.25" (x2) FEMALE COUPLING NUT

SECTION A-A

SECTION B-B

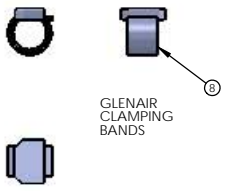
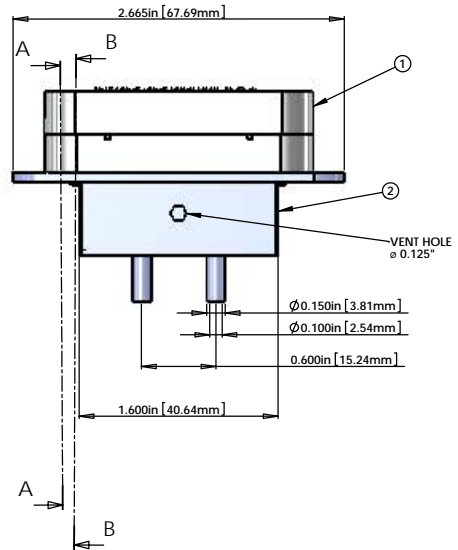

V25Q-48 CABLE ASSEMBLY CIRCUIT SUMMARY
V-DB25 M/S1,9-48-2,DB9 F/S5

FROM					TO		
CONNECTOR J1 - 25 PIN SUBMINI_D MALE CONNECTOR (PEEK)					CONNECTOR J2 - 9 PIN SUBMINI_D FEMALE CONNECTOR (PEEK)		
PIN	WIRE NAME	COLOR	LENGTH	TWISTED PAIR	PIN	WIRE NAME	SIGNAL
1,9	SHELL (BRAID)		48in		5, SHELL	SHELL (BRAID)	SHIELD
1,9	(CABLE 1) WIRE 1	White	48in		5, SHELL	(CABLE 1) WIRE 1	SHIELD
2	(CABLE 1) WIRE 2	White	48in	TP-1	4	(CABLE 1) WIRE 2	POWER
14	(CABLE 1) WIRE 14	White	48in	TP-1	9	(CABLE 1) WIRE 14	POWER - RTN
3	(CABLE 1) WIRE 3	White	48in	TP-2	3	(CABLE 1) WIRE 3	POWER +
15	(CABLE 1) WIRE 15	White	48in	TP-2	8	(CABLE 1) WIRE 15	POWER + RTN
4	(CABLE 1) WIRE 4	White	48in	TP-3	2	(CABLE 1) WIRE 4	LOCK +
16	(CABLE 1) WIRE 16	White	48in	TP-3	7	(CABLE 1) WIRE 16	LOCK -
5	(CABLE 1) WIRE 5	White	48in	TP-4	1	(CABLE 1) WIRE 5	SIG +
17	(CABLE 1) WIRE 17	White	48in	TP-4	6	(CABLE 1) WIRE 17	SIG -
CONNECTOR J3 - 9 PIN SUBMINI_D FEMALE CONNECTOR (PEEK)					CONNECTOR J3 - 9 PIN SUBMINI_D FEMALE CONNECTOR (PEEK)		
PIN	WIRE NAME	COLOR	LENGTH	TWISTED PAIR	PIN	WIRE NAME	SIGNAL
1,9	SHELL (BRAID)		48in		5, SHELL	SHELL (BRAID)	SHIELD
1,9	(CABLE 2) WIRE 9	White	48in		5, SHELL	(CABLE 2) WIRE 9	SHIELD
10	(CABLE 2) WIRE 10	White	48in	TP-5	4	(CABLE 2) WIRE 10	POWER -
22	(CABLE 2) WIRE 22	White	48in	TP-5	9	(CABLE 2) WIRE 22	POWER - RTN
11	(CABLE 2) WIRE 11	White	48in	TP-6	3	(CABLE 2) WIRE 11	POWER +
23	(CABLE 2) WIRE 23	White	48in	TP-6	8	(CABLE 2) WIRE 23	POWER + RTN
12	(CABLE 2) WIRE 12	White	48in	TP-7	2	(CABLE 2) WIRE 12	LOCK +
24	(CABLE 2) WIRE 24	White	48in	TP-7	7	(CABLE 2) WIRE 24	LOCK -
13	(CABLE 2) WIRE 13	White	48in	TP-8	1	(CABLE 2) WIRE 13	SIG +
25	(CABLE 2) WIRE 25	White	48in	TP-8	6	(CABLE 2) WIRE 25	SIG -

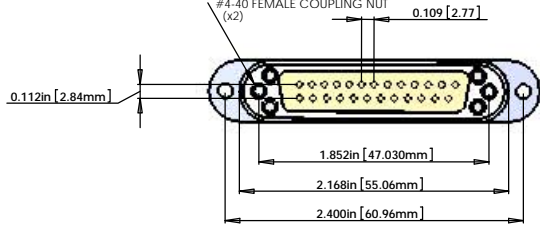

0.375in [9.52mm] 0.739in [18.76mm]

CONNECTOR J2, J3

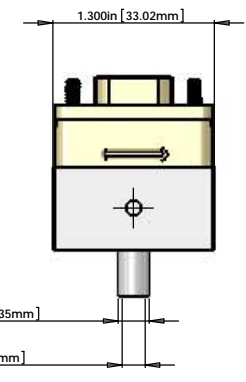
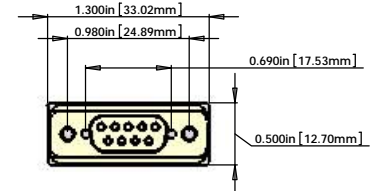

BILL OF MATERIALS

ITEM NO.	PART NUMBER	DESCRIPTION	QTY.	LENGTH *
1	CUSTOM DB25 MALE	DB25 MALE CONNECTOR (J1) FOR UHV (METALIZED PEEK)	1	
2	CUSTOM DB25 BACKSHELL	DB25 CONNECTOR BACKSHELL FOR UHV (STAINLESS)	1	
3	CUSTOM DB9 FEMALE	DB9 FEMALE CONNECTOR (J2 and J3) FOR UHV (PEEK)	2	
4	CUSTOM DB9 BACKSHELL	DB9 CONNECTOR BACKSHELL FOR UHV (STAINLESS)	2	
5	C1	9 COND. (4 TW PAIR + 1 WIRE + SHIELD) CABLE WITH (6) COPPER BRAID (SHIELD) AND (7) PEEK OVERBRAID	2	48"
6	COPPER BRAID	CONTINENTAL CORDAGE PART # 24x3x40BC	2	48"
7	PEEK BRAID	PART #6759 MANUFACTURED WITH ZEUS 0.015" BLACK PEEK DRAWN MONOFILAMENT	2	48"
8	GLENAIR 600-052	GLENAIR 600-052 STANDARD BRAID CLAMP	4	

* NOTE: USE WHATEVER LENGTH IS NECESSARY FOR THE INTERNAL WIRING OF THE CONNECTORS AND STRIP LENGTH TO ACHIEVE THE CORRECT OVERALL LENGTHS.

NOTES: (UNLESS OTHERWISE SPECIFIED)

- MATERIAL:**
 - CONNECTOR SHELL - PEEK OR METALIZED PEEK - VICTREX 450GL30
 - BACKSHELL - STAINLESS STEEL WITH VENT HOLE.
 - CONTACTS - BERYLLIUM COPPER ALLOY C17200 0.000050 MIN. GOLD OVER NICKEL
 - HARDWARE: CORROSION RESISTANCE STEEL, PASSIVATED
 - PEEK BRAID - PEEK VICTREX GRADE IDS-450CA30 CARBON LOADED - SUPPLIED BY LIGO
- CABLE** 9 COND. 28 AWG (40 STRD 44 AWG) WITH 2 LAYERS OF KAPTON TAPE (SUPPLIED BY LIGO) 4 TWISTED PAIRS (4 TO 5 TWISTS PER INCH) + 1 WIRE OVERALL 40AWG COPPER BRAID 50% COVERAGE (SUPPLIED BY LIGO) OVERALL PEEK BRAID MIN. 50% COVERAGE (SUPPLIED BY LIGO) OVERALL CABLE O.D. WILL BE APPROX. 0.240 IN.
- CONNECTORS** WILL BE SUPPLIED WITH HARDWARE (LENGTH OF SCREWS AS SHOWN ARE APPROXIMATE SCREWS SHOULD BE THE PROPER LENGTH FOR PROPER MATING)

STANDARD 9-PIN D-SUB FEMALE MIL-C-24308

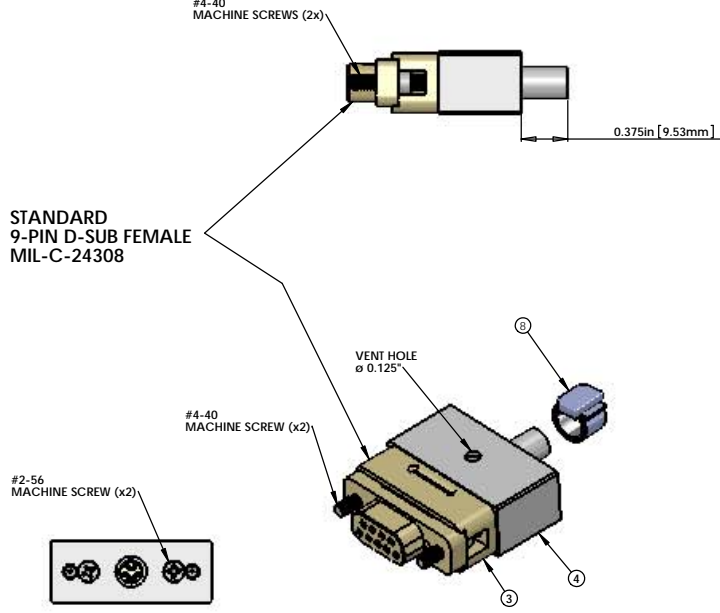

V-DB25 M/S1,9-48-2,DB9 F/S5

STANDARD USE FOR THIS CABLE

SUBSYSTEM	AIR/VAC	STANDARD USE
SEI	IN-VAC	FROM BRACKET TO I4-C PODS

NOTES AND TOLERANCES: UNLESS OTHERWISE SPECIFIED
 1. INTERPRET DRAWING PER ASME Y14.5-1994.
 2. REMOVE ALL SHARP EDGES: 0.05-0.15 FOR MACHINED PARTS. ROUND ALL EDGES APPROXIMATELY R.02 FOR SHEET METAL PARTS.
 3. DO NOT SCALE FROM DRAWING.
 4. ALL MACHINING FLUIDS MUST BE FULLY SYNTHETIC, FULLY WATER SOLUBLE AND FREE OF SULFUR, SILICONE, AND CHLORINE.

DIMENSIONS ARE IN: TOLERANCES: .XX ± .XXX ± ANGULAR: ±

MATERIAL: N/A FINISH: N/A μINCH NEXT ASSY: SYSTEM: SUB-SYSTEM: SEI DESIGNER: @/08/07 DATE: 2/28/08/2011 DRAFTER: E.BROCKWELL CHECKER: APPROVAL: SCALE: 2:1 PROJECTION: SHEET 1 OF 1

LIGO CALIFORNIA INSTITUTE OF TECHNOLOGY MASSACHUSETTS INSTITUTE OF TECHNOLOGY PART NAME: CUSTOM CABLE SPECIFICATION V25Q-48

DESIGNER: @/08/07 DATE: 2/28/08/2011 DRAFTER: E.BROCKWELL CHECKER: APPROVAL: SCALE: 2:1 PROJECTION: SHEET 1 OF 1

DWG. NO: **D1100154** REV: **v1**