



LIGO Laboratory / LIGO Scientific Collaboration

LIGO-T1100062-v2

Advanced LIGO

11 March 2011

aLIGO I&Q RF Demodulator Test Procedure

Richard Abbott

Distribution of this document:
LIGO Scientific Collaboration

This is an internal working note
of the LIGO Laboratory.

California Institute of Technology
LIGO Project – MS 18-34
1200 E. California Blvd.
Pasadena, CA 91125
Phone (626) 395-2129
Fax (626) 304-9834
E-mail: info@ligo.caltech.edu

Massachusetts Institute of Technology
LIGO Project – NW22-295
185 Albany St
Cambridge, MA 02139
Phone (617) 253-4824
Fax (617) 253-7014
E-mail: info@ligo.mit.edu

LIGO Hanford Observatory
P.O. Box 1970
Richland WA 99352
Phone 509-372-8106
Fax 509-372-8137

LIGO Livingston Observatory
P.O. Box 940
Livingston, LA 70754
Phone 225-686-3100
Fax 225-686-7189

<http://www.ligo.caltech.edu/>

1 Overview

This test procedure applies to I&Q demodulator circuit board LIGO-D0902745-v3 contained within chassis assembly D0902796. There are two variants of the demodulator chassis, one for LSC photodetectors, and one for ASC (WFS) type photodetectors. A block diagram of the I&Q RF demodulator circuit board common to both variants is shown in Figure 1. Four such demodulator cells are packaged in one chassis. Refer to LIGO-T1000044 for principles of operation.

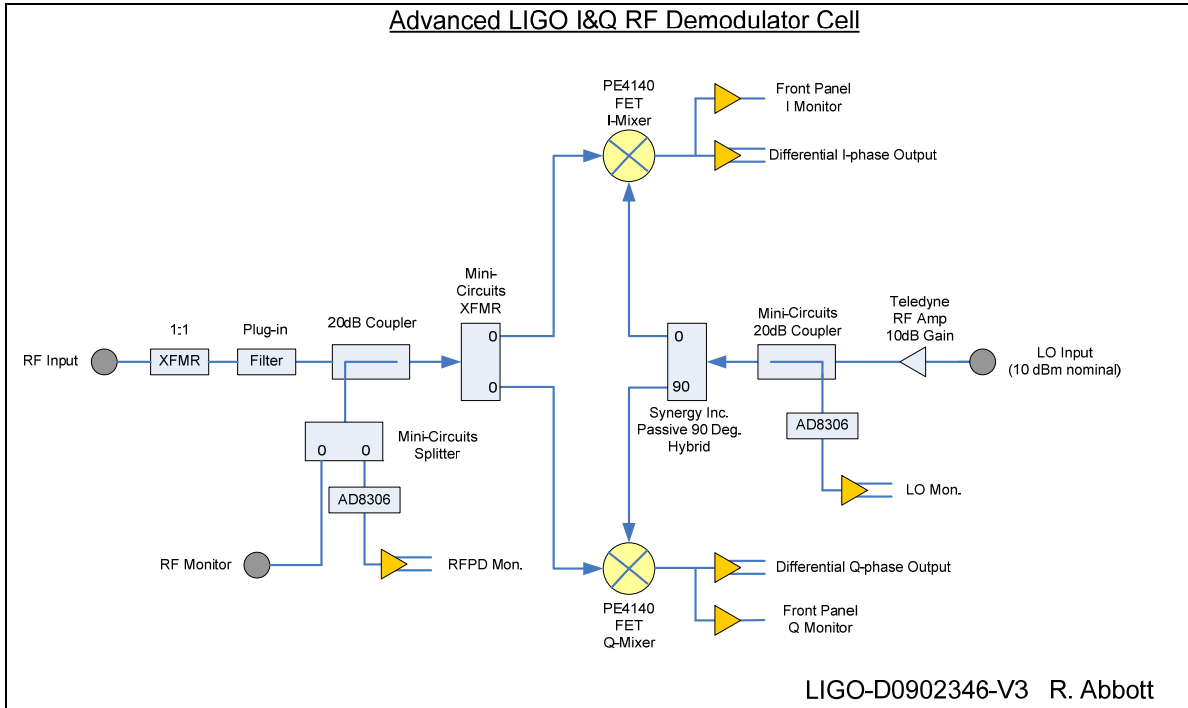

Figure 1 I&Q Demodulator Circuit Block Diagram

2 Testing

Each production chassis must be functionally tested and the results recorded in Section 4. Unless otherwise noted, the local oscillator level applied to the rear of the chassis is set to +10dBm, +/-0.2dBm for all RF measurements. It is assumed that the person using this procedure is familiar with RF Network Analyzers, Dynamic Signal Analyzers, and rudimentary test equipment including oscilloscopes and multimeters.

Serial Number Data

- Record all serial number data in Table 1

DC Tests

- Apply +/- 18, +/-200 mV Volts DC to the chassis under test and record front panel LED operation, total positive and negative power supply current, internal regulator output voltage and individual circuit board power supply currents as required in Table 2.

RF Tests

- Using a calibrated and normalized RF network analyzer, measure the insertion loss from each of the four front panel RF inputs to the respective RF monitor ports. Record the insertion loss at each frequency required in Table 4.
- Apply an RF or LO input at the prescribed frequency in accordance with Table 5. For each combination, record the DC value of each of the four RF and LO level detector responses.
- Apply an RF or LO input at the prescribed frequencies in accordance with Table 6. For each combination, record the amplitude of the differential IF beat note as required in Table 6.

IF Tests

- As detailed in Section 4.7, use the cross correlation setup in an SR785 and measure the I&Q balance at the front panel BNC outputs and record the results per Table 7 through Table 10.
- Use an SR785 to measure the IF output noise, with the associated RF input terminated in 50 ohms. Record results as required in Table 11 through Table 14.
- Using a pair of RF signal generators and an oscilloscope, measure the -3dB bandwidth of the IF chain. Record the results in Table 15.

3 Reference for chassis front and rear panel layout

Figure 2, Demodulator Front Panel

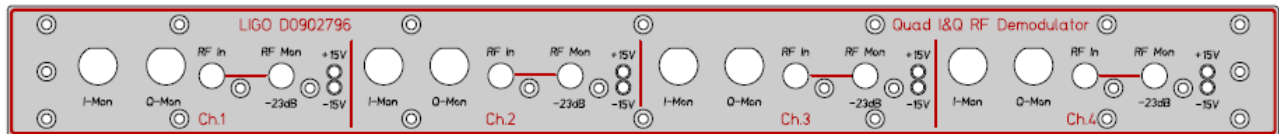

Figure 3, LSC Demodulator Rear Panel

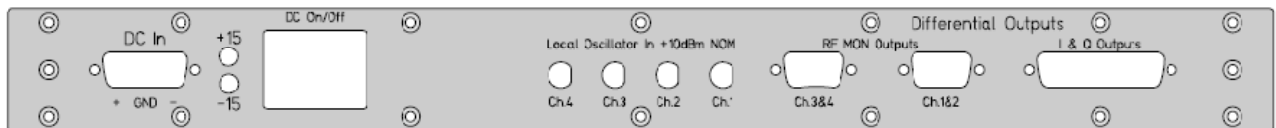

Figure 4, ASC Demodulator Rear Panel



4 Test Data Tables

4.1 General Information

Table 1, Serial Number Data

Chassis Serial Number	ASC or LSC version?	Ch.1 PCB Serial Number	Ch.2 PCB Serial Number	Ch.3 PCB Serial Number	Ch.4 PCB Serial Number

4.2 DC Power Supply Data

Total chassis and individual circuit board quiescent current draw is recorded in Table 2. For the individual circuit boards, unplug all but one board at a time and record the chassis current draw of the +/- 18VDC supply. Use caution in believing the digital readouts of laboratory triple output power supplies. Their meters are not highly accurate. When in doubt, use a multimeter on the appropriate scale in series with the supply to be measured.

Table 2, Record of DC Test Data

Parameter	Typical Value	Allowable Range	Measured Value
Front Panel +/- 15VDC Power LEDs	All Lit, front and rear	N/A	
+18VDC, +/-0.25VDC TOTAL supply current	890mA	+/- 50mA	
-18VDC, +/-0.25VDC TOTAL supply current	300mA	+/- 50mA	
Regulated Internal DC Voltage under full load (all four boards)	+15VDC, -15VDC	+/- 0.5VDC	
+18VDC, +/-0.25VDC supply current (Board 1)	240mA	+/- 20mA	
-18VDC, +/-0.25VDC supply current (Board 1)	80mA	+/- 20mA	
+18VDC, +/-0.25VDC supply current (Board 2)	240mA	+/- 20mA	
-18VDC, +/-0.25VDC supply current (Board 2)	80mA	+/- 20mA	
+18VDC, +/-0.25VDC supply current (Board 3)	240mA	+/- 20mA	
-18VDC, +/-0.25VDC supply current (Board 3)	80mA	+/- 20mA	
+18VDC, +/-0.25VDC supply current (Board 4)	240mA	+/- 20mA	
-18VDC, +/-0.25VDC supply current (Board 4)	80mA	+/- 20mA	

4.3 DC Offsets on Each IF Output

As a general measure of the health, the DC offset at the differential outputs for each channel must be measured. Apply LO of 45MHz, 10dBm +/- 0.2dB to the channel under test. Using a multimeter, measure the DC offset at each differential output on the associated rear panel D-sub connector. Record the results in Table 3.

Table 3, IF Output DC Offset

<i>Differential DC Measurement Point</i>	<i>Typical DC Offset</i>	<i>Allowable Range</i>	<i>Measured DC Offset</i>	
			I	Q
Channel 1	0VDC	+/- 10mV		
Channel 2	0VDC	+/- 10mV		
Channel 3	0VDC	+/- 10mV		
Channel 4	0VDC	+/- 10mV		

4.4 Coupling Factor for Front Panel Monitors

Using a calibrated and normalized RF network analyzer, measure the insertion loss from each front panel SMA RF input to its respective RF monitor. Use a drive level of 0dBm +/- 0.2dB at each of the required frequencies. Record the test data in Table 4.

Table 4, RF Monitor Test Data

Parameter	Typical Value	Allowable Range	Measured Values		
			9 MHz	45 MHz	100 MHz
Chan.1 RF In to RF Monitor Gain	-23dB	+/- 1dB			
Chan.2 RF In to RF Monitor Gain	-23dB	+/- 1dB			
Chan.3 RF In to RF Monitor Gain	-23dB	+/- 1dB			
Chan.4 RF In to RF Monitor Gain	-23dB	+/- 1dB			

4.5 RF Level Detector Calibration Data

Apply a signal of the indicated magnitude to the RF or LO input on the front and rear chassis SMA connectors as specified in Table 5. Using a multimeter, record the DC voltage as measured differentially at the differential RF monitor outputs on the rear of the chassis (see Section 3, Reference for chassis front and rear panel layout). The presence of a four way power splitter on the LO input to the ASC version of the demodulator chassis is the reason for the second typical value shown for the LO detected level. Utilize the typical value dictated by the chassis type under test.

Table 5, RF Level Detector Response

RF Freq/Level	LO Freq/Level	Typical Value LSC or ASC Version	Allowable Range	Measured Value				
				CH1	CH2	CH3	CH4	
45 MHz (-20dBm)	45 MHz (-20dBm +/- 0.2dB)	LO	7.9VDC (LSC) 7.0VDC(ASC)	+/-0.25VDC				
		RF	6.2VDC					
45 MHz (-10dBm)	45 MHz (-10dBm +/- 0.2dB)	LO	9.1VDC (LSC) 8.0VDC (ASC)	+/-0.25VDC				
		RF	7.4VDC					
45 MHz (0dBm)	45 MHz (0dBm +/- 0.2dB)	LO	10.3VDC (LSC) 9.0VDC (ASC)	+/-0.25VDC				
		RF	8.6VDC					
45 MHz (10dBm)	45 MHz (10dBm +/- 0.2dB)	LO	11.5VDC (LSC) 10VDC (ASC)	+/-0.25VDC				
		RF	9.8VDC					

4.6 IF Beat note Measurements

Using a pair of RF signal generators, apply the indicated amplitude and frequency signals to the chassis under test as detailed in Table 6. There is a single rear panel LO input for the ASC (wavefront sensor) variant of the demodulator chassis simplifying the test setup. For the LSC version, the LO cable must be moved from channel to channel as needed. The presence of a four way power splitter on the LO input to the ASC version of the demodulator chassis is the reason for the second typical value shown for the IF Beat Note. Utilize the typical value dictated by the chassis type under test.

The IF beat note is measured differentially at the rear panel D-sub outputs for each channel under test using an SR785. Be sure to set the dynamic signal analyzer FFT window function to “flat top” during this amplitude measurement in order to accurately measure the peak to peak voltage at each beat note frequency.

Table 6, IF Beat Note Amplitude vs. Frequency Measurement Data

RF Freq/Level	LO Freq/Level	IF Beat Note Typical Value LSC or ASC version	Allowable Range	Measured Value (p-p)			
				CH1	CH2	CH3	CH4
				I	I	I	I
				Q	Q	Q	Q
45 MHz (0dBm, +/- 0.2dB)	45.0001 MHz (10dBm, +/- 0.2dB)	100Hz @ 6.9Vp-p (LSC), 0.9Vp-p (ASC)	+/-0.2Vp-p				
45 MHz (0dBm, +/- 0.2dB)	45.001 MHz (10dBm, +/- 0.2dB)	1kHz @ 6.9Vp-p (LSC), 0.9Vp-p (ASC)	+/-0.2Vp-p				
45 MHz (0dBm, +/- 0.2dB)	45.01 MHz (10dBm, +/- 0.2dB)	10kHz @ 6.9Vp-p (LSC), 0.9Vp-p (ASC)	+/-0.2Vp-p				
45 MHz (0dBm, +/- 0.2dB)	45.1 MHz (10dBm, +/- 0.2dB)	100kHz @ 7.2Vp-p (LSC), 0.9Vp-p (ASC)	+/-0.2Vp-p				

4.7 IQ Amplitude and Phase Balance

When measuring the IF beat note, the I and Q IF outputs should ideally be exactly equal in magnitude, and 90 degrees out of phase. Section 5 of this document has a printout of the settings file for the SR785 Dynamic Signal Analyzer used to perform an I and Q balance measurement. These settings can be restored to the machine by obtaining the machine setup file from the DCC and loading them onto the SR785 via a floppy disk. LIGO Document T1100087 is actually this file.

Once the settings file is loaded into the SR785, apply an LO and RF signal at the indicated frequencies shown in Table 7. The LO signal level should be 10dBm +/- 0.2dB, and the RF signal level should be 0dBm +/- 0.2dB.

On the front panel of the I&Q demodulator are two BNC monitoring jacks per channel. These are IF monitors of the I and Q demodulated outputs. Apply the I monitor signal to the SR785 Channel 1, A input. Apply the Q monitor signal to the SR785 Channel 2, A input. Record data as needed in Table 7 through Table 10.

Table 7, Channel 1 IQ Balance

Channel 1 RF Input and LO Frequency	Typical Amplitude Balance	Allowable Range	Typical Phase Balance	Allowable Range	Measured Amplitude Balance	Measured Phase Balance
9MHz & 9.01MHz	0dB	+/- 0.5dB	-90 Deg.	+/- 5 Deg.		
36MHz & 36.01MHz	0dB	+/- 0.5dB	-90 Deg.	+/- 5 Deg.		
45MHz & 45.01MHz	0dB	+/- 0.5dB	-90 Deg.	+/- 5 Deg.		
100MHz & 100.01MHz	0dB	+/- 0.5dB	-90 Deg.	+/- 5 Deg.		

Table 8, Channel 2 IQ Balance

Channel 2 RF Input and LO Frequency	Typical Amplitude Balance	Allowable Range	Typical Phase Balance	Allowable Range	Measured Amplitude Balance	Measured Phase Balance
9MHz & 9.01MHz	0dB	+/- 0.5dB	-90 Deg.	+/- 5 Deg.		
36MHz & 36.01MHz	0dB	+/- 0.5dB	-90 Deg.	+/- 5 Deg.		
45MHz & 45.01MHz	0dB	+/- 0.5dB	-90 Deg.	+/- 5 Deg.		
100MHz & 100.01MHz	0dB	+/- 0.5dB	-90 Deg.	+/- 5 Deg.		

Table 9, Channel 3 IQ Balance

Channel 3 RF Input and LO Frequency	Typical Amplitude Balance	Allowable Range	Typical Phase Balance	Allowable Range	Measured Amplitude Balance	Measured Phase Balance
9MHz & 9.01MHz	0dB	+/- 0.5dB	-90 Deg.	+/- 5 Deg.		
36MHz & 36.01MHz	0dB	+/- 0.5dB	-90 Deg.	+/- 5 Deg.		
45MHz & 45.01MHz	0dB	+/- 0.5dB	-90 Deg.	+/- 5 Deg.		
100MHz & 100.01MHz	0dB	+/- 0.5dB	-90 Deg.	+/- 5 Deg.		

Table 10, Channel 4 IQ Balance

Channel 4 RF Input and LO Frequency	Typical Amplitude Balance	Allowable Range	Typical Phase Balance	Allowable Range	Measured Amplitude Balance	Measured Phase Balance
9MHz & 9.01MHz	0dB	+/- 0.5dB	-90 Deg.	+/- 5 Deg.		
36MHz & 36.01MHz	0dB	+/- 0.5dB	-90 Deg.	+/- 5 Deg.		
45MHz & 45.01MHz	0dB	+/- 0.5dB	-90 Deg.	+/- 5 Deg.		
100MHz & 100.01MHz	0dB	+/- 0.5dB	-90 Deg.	+/- 5 Deg.		

4.8 IF Output Noise Spectra

With an LO of 45MHz, 10dBm +/- 0.2dB applied; terminate each of the RF inputs under test in 50 ohms. Measure the IF output referred noise differentially at the rear panel D-sub output for each channel as required. Record the results in Table 11 through Table 14.

Table 11, Channel 1 IF Noise

IF Measurement Frequency	Typical Amplitude (dBVrms/ $\sqrt{\text{Hz}}$)	Allowable Range	Measured Amplitude dBVrms/ $\sqrt{\text{Hz}}$	
			I	Q
100Hz	-145	<140		
1kHz	-147	<140		

Table 12, Channel 2 IF Noise

IF Measurement Frequency	Typical Amplitude dBVrms/ $\sqrt{\text{Hz}}$	Allowable Range	Measured Amplitude dBVrms/ $\sqrt{\text{Hz}}$	
			I	Q
100Hz	-145	<140		
1kHz	-147	<140		

Table 13, Channel 3 IF Noise

IF Measurement Frequency	Typical Amplitude dBVrms/ $\sqrt{\text{Hz}}$	Allowable Range	Measured Amplitude dBVrms/ $\sqrt{\text{Hz}}$	
			I	Q
100Hz	-145	<140		
1kHz	-147	<140		

Table 14, Channel 4 IF Noise

IF Measurement Frequency	Typical Amplitude dBVrms/ $\sqrt{\text{Hz}}$	Allowable Range	Measured Amplitude dBVrms/ $\sqrt{\text{Hz}}$	
			I	Q
100Hz	-145	<140		
1kHz	-147	<140		

4.9 IF -3dB Bandwidth

Apply a fixed 45MHz RF generator at 0dBm +/- 0.2dB as the front panel RF input, and a variable frequency LO starting at a frequency of 45.001MHz and a fixed level of 10dBm +/- 0.2dB applied to the LO input on the rear of the chassis under test. Use a dual channel oscilloscope with a pair of probes to view the IF beat note differentially on the rear panel D-sub for the channel under test. Increment the LO frequency until a 3dB decrease in the IF beat note is observed. Record the frequency corresponding to the -3dB frequency in Table 15

Table 15, Channel 2 IF Bandwidth

Channel	Typical -3dB Bandwidth	Allowable Range	Measured -3dB IF Bandwidth	
			I (kHz)	Q (kHz)
1	370kHz	+/- 30kHz		
2	370kHz	+/- 30kHz		
3	370kHz	+/- 30kHz		
4	370kHz	+/- 30kHz		

5 Appendix

The SR785 Settings associated with the I and Q phase and magnitude balance measurement.

Input	Ch 1	Ch 2
Source	Analog	Analog
Config	Dual Chan.	Dual Chan.
Mode	A	A
Ground	Float	Float
Coupling	AC	AC
Range	6 dBVpk	6 dBVpk
AA Filter	On	On
A-Wt Filter	Off	Off
Auto Range	Up Only	Up Only
Auto Offset	On	On
EU	Off	Off
EU Label	m/s	m/s
EU/Volt	1 EU/V	1 EU/V
User Label	EU	EU
Tachs/Rev	1	1
Tach Level	0.00 V	0.00 V
Tach Trigger	TTL	TTL
Tach Slope	Rising	Rising
Tach Holdoff	Off	Off
ShowTach	Off	Off
Xdcr Convert	m/s	m/s

Measure	Display A	Display B
Measurement	Cross Spec.	FFTUsrFn1
View	Phase	Log Mag
Units	deg	dB
dB Units	Off	On
Peak Units	pk	off
PSD Units	Off	Off
Phase Units	deg	deg
dBm Ref	50	50
Base Freq	102.4 kHz	102.4 kHz
Span	400 Hz	400 Hz
Start Freq	9.8 kHz	9.8 kHz
Lines	800	800
Window	BMH	BMH
Force	3.90625 ms	3.90625 ms
Expo	50.00%	50.00%

Average	Display A	Display B
Comp. Average	Yes	Yes
Type	Exp. / Cont.	Exp. / Cont.
Display	RMS	RMS
Number	20	20

Time Incr	100.00%	100.00%
Reject	Off	Off
Preview	Off	Off
Prv Time	2 s	2 s

Display	Display A	Display B
Ymax	250	50
Y/div	50	10
Xcenter	2.86479 k	50
X/div polar	572.958	10
Ycenter	2.86479 k	50
Y/div polar	572.958	10
Pan	0	0
Zoom	x1	x1
Format	Dual	Dual
X Axis	Linear	Linear
Grid	On	On
Grid Div	10	10
Grid Type	Rectangular	Rectangular
Phase Suppress	0.00E+00	0.00E+00
d/dx Window	0.5	0.5

Marker	Display A	Display B
Marker	On	On
Mode	Normal	Normal
Seeks	Mean	Mean
Width	Spot	Spot
Relative	Off	Off
X Relative	Off	Off
X Rel	0	0
Y Rel	0	0
# Harmonics	1	1
Display	Fundamental	Fundamental
Readout	Absolute	Absolute
Sideband Sep	0	0
# Sidebands	10	10
Band Exclude	none	none
Band Ratio	/	/

Waterfall	Display A	Display B
Wfall Display	Normal	Normal
Wfall Storage	Off	Off
Storage Mode	All	All
Total Count	253	253
Skip	30	30
View Count	10	10
Trace Height	70%	70%
Angle	-26	-26

Fast Angles	Off	Off
Threshold	0%	0%
Hidden Lines	Invisible	Invisible
Paused Draw	Normal	Normal

Source		
Source	0	[0=Off, 1=On]
Type	0	[0=Sine, 1=Chirp, 2=Noise, 3=Arb]
Sine Freq 1	10.24 kHz	
Sine Amp 1	500.0 mVpk	
Sine Freq 2	51.2 kHz	
Sine Amp 2	0.0 mVpk	
Sine Offset	0.0 mV	
Chirp Amp	1000.0 mV	
Chirp Burst	100.00%	
Source Display	Display A	
Noise Amp	1000.0 mV	
Noise Type	BL White	
Noise Burst	100.00%	
Arb Amp	100.00%	
Arb Rate	262.1 kHz	
Arb Source	Arb. Buffer	
Arb Start	0	
Arb Length	4 kPts	

Trigger		
Arming Mode	Auto Arm	
Trigger Source	Cont	
Trigger Level	0%	
Trigger Slope	Rising	
Delay1	0 s	
Delay2	0 s	
Source Mode	Continuous	
Start RPM	Off	
Start RPM	50	
Delta RPM	Abs. Change	
Delta RPM	10	
Time Step	100 ms	

Capture		
Capt Channels	Ch1+Ch2	
Capt Mode	1 Shot	
Capt Length	2024 kPts/ch	
Capt Rate	262.1 kHz	
Auto Pan	On	
Playback Start	0	
Playback Len	2024 kPts/ch	
Playback Mode	1-Shot	

Playback Speed	Normal	
----------------	--------	--

Memory		
Capt Memory	2025 Blks	
Wfall Memory	2024 Blks	
Arb Memory	2 Blks	

System		
Output To	RS232	
GPIO Address	10	
Override REM	Yes	
Baud Rate	9600 bd	
Word Length	8 bits	
Parity	None	
Key Click	Off	
Alarms	On	
Alarm Vol	Noisy	
Done Vol	Noisy	
Audible Ovd	On	
Screen Saver	On	
Saver Delay	10 m	
Freq Format	Exact Bin	
Node Info	No	

Output		
Print Screen Key	ASCII Dump	
Printer Type	PCX 8 bit	
Bitmap Area	Graphs	
Plotter Type	PostScript	
Destination	Disk File	
GPIO Control	SR785	
Plotter Address	2	
Print Bright	12%	
Print Dim	White	
Print Black	Black	
Print Graph	Black on White	
Text Pen	1	
Grid Pen	1	
Trace Pen	1	
Marker Pen	1	