



LIGO Laboratory / LIGO Scientific Collaboration

LIGO-T1100068-v17

Advanced LIGO

March 28, 2012

Photon Calibrator Final Design

Jonathan Berliner, Rick Savage

Distribution of this document:
LIGO Scientific Collaboration

This is an internal working note
of the LIGO Laboratory.

California Institute of Technology
LIGO Project – MS 18-34
1200 E. California Blvd.
Pasadena, CA 91125
Phone (626) 395-2129
Fax (626) 304-9834
E-mail: info@ligo.caltech.edu

Massachusetts Institute of Technology
LIGO Project – NW22-295
185 Albany St
Cambridge, MA 02139
Phone (617) 253-4824
Fax (617) 253-7014
E-mail: info@ligo.mit.edu

LIGO Hanford Observatory
P.O. Box 159
Richland WA 99352
Phone 509-372-8106
Fax 509-372-8137

LIGO Livingston Observatory
P.O. Box 940
Livingston, LA 70754
Phone 225-686-3100
Fax 225-686-7189

<http://www.ligo.caltech.edu/>

- **Table of Contents**

1	Introduction	5
1.1	Preface	5
1.2	Principle of Operation	6
2	Performance Requirements	7
2.1	Accuracy of Induced Displacements: Absolute Power Calibration, Beam Positioning on ETM Surface 7	
2.1.1	Absolute Power Calibration.....	7
2.1.2	Beam Positioning on ETM Surface	8
2.2	Precision of Induced Displacements: Laser Power	11
2.3	Displacement Noise: Relative Power Noise and Harmonic Noise	14
2.4	UTC Synchronization	16
2.5	Laser Wavelength	16
2.6	Continuous Excitation lines	17
2.7	Swept-Sine Measurements.....	17
2.8	Reliability	17
3	In-Vacuum Systems: Beam Paths and Periscopes.....	17
3.1	Beam Paths and Periscopes.....	19
3.1.1	H1 and L1.....	21
3.1.2	H2	23
3.2	Beam Alignment and Localization.....	24
3.2.1	Initial Alignment	25
3.2.2	Final Alignment.....	26
4	Transmitter Module.....	27
4.1	Laser	28
4.2	Acousto-Optic Modulator.....	28
4.3	Internal Laser Power Sensors	28
4.4	Physical and Environmental Monitors	29
4.5	Breadboard	29
4.6	Enclosures	29
4.7	Viewport Protectors.....	29
4.8	Transmitter Module Pylon	30
5	Photon Calibrator Receiver Module	30
5.1	Internal Power Sensor.....	30
5.2	Calibration of the Photodetector.....	31
5.3	Receiver Module Pylon	31
6	Absolute Laser Power Calibration.....	32
6.1	The Gold Standard Laser Power Sensor.....	32
6.2	The Working Standard Laser Power Sensors	33
7	Calibration Procedures.....	34
7.1	Calibration of the Working Standard	34
7.2	Calibration of Transmitter and Receiver Module Power Sensors.....	36

7.2.1 Frequency of Calibration 36

8 Failure Modes and Hazards 36

8.1 Internal Photodetector Fails.....36

8.2 Gold Standard or Working Standard Fails36

8.3 Laser Fails37

8.4 Misalignment of Receiver-Side Periscope37

8.5 Misalignment of Transmitter-Side Periscope.....37

8.6 Damage to Viewport Glass37

9 Required Drawings and Documents 37

9.1 Hardware Drawings/Bill of Materials.....37

9.1.1 Transmitter Pylon (same for all ETMs, 6 required) 37

9.1.2 Transmitter Module (same for all ETMs, 6 required)..... 37

9.1.3 Receiver Module (same for all ETMs, 6 required)..... 38

9.1.4 In-Vacuum Pcal-Video Cam Periscope Assembly (same for each ETM, except left-right symmetry) 38

9.1.4.1 H1/L1 (4 required) 38

9.1.4.2 H2 (2 required) 39

9.1.5 ETM Camera In-Vacuum Periscope Hardware [Mike Smith, ISC] (same for each ETM, except left-right symmetry) 39

9.1.5.1 H1/L1 (4 required) 39

9.1.5.2 H2 (2 required) 39

Acronyms

μ - Mean

σ – Standard Deviation

1 PPS – 1 Pulse Per Second timing system

AOM – Acousto-Optic Modulator

AR - Antireflection mirror coating

BS - Beam Splitter

BSC – Basic Symmetric Chamber

CDS – Control and Data System

DAQ – Data Acquisition System

GS – Gold Standard

HR – High Reflectance mirror coating

HWP- Half Wave Plate

IFO - LIGO interferometer

ISC- Interferometer Sensing and Control

Pcal – Photon Calibrator

PM – Internal Power Monitor that is located inside of the Photon Calibrator box

ppm - parts per million

QWP – Quarter Wave Plate

RPN – Relative Power Noise

RMS – root mean square

SNR – Signal-to-Noise Ratio

WS – Working Standard

WSH – Working Standard Hanford

WSL – Working Standard Livingston

▪ **Relevant Documents**

DCC references in italics refer to external documents.

Title	LIGO-DCC#:
<i>Precise calibration of LIGO test mass actuators using photon radiation pressure</i>	P080118
<i>Accurate calibration of test mass displacement in the LIGO interferometers</i>	P0900155
<i>Photon Calibrator Upgrades Proposal</i>	T070094
<i>Photon Calibrator Conceptual Design Document</i>	T070167
<i>Photon Calibrator Response to Reviewer's Report</i>	G070601
<i>Photon Calibrator Design Requirements</i>	T1100044
<i>aLIGO Calibration White Paper</i>	T1100122
<i>Viewport Subsystem Preliminary Design Document</i>	T1000023
<i>Optimal calibration accuracy for gravitational-wave detectors</i>	PRD-Aug 2009
<i>NIST: Report of Calibration for First Photon Calibrator Calibration</i>	T1000637
<i>NIST Report of Special Test</i>	T070246
<i>Photon calibrator gold standard calibration at NIST - Report of Calibration (42110CA)</i>	T1000189
<i>NIST Measurement Services: cw Laser Power and Energy Calibrations at NIST</i>	NIST SP 250-75
<i>aLIGO Photon Calibrator Errors due to Elastic Deformation</i>	G1100332
<i>eLIGO Photon Calibrator investigation: long term stability of DARM actuation</i>	G1000254
<i>Characterization of Photon Calibrator data from S6</i>	G1000913
<i>Photon Calibrator Investigations During S6</i>	G1100189
<i>AOS Pcal Technical Status - NSF 2011</i>	G1100454
<i>S6 V2 Calibration Review</i>	T1100597
<i>Controlling calibration errors in gravitational-wave detectors by precise location of calibration forces (paper)</i>	P1100166

<i>Controlling calibration errors in gravitational-wave detectors by precise location of calibration forces (poster)</i>	G1100988
<i>Photon Calibrator Budget Estimate</i>	T1100643

1 Introduction

1.1 Preface

This document describes the Preliminary and Final Design of the Advanced LIGO (aLIGO) Photon Calibrator subsystem (“Pcal”). It details engineering and design specifications, overall beam, hardware, and electrical layouts, as well as expected modes of operation. The design is based on the Initial LIGO (iLIGO) and Enhanced LIGO (eLIGO) Pcal. It responds to input received from the LSC Calibration Committee, mostly in the form of operational requirements.

Pcals were introduced during iLIGO principally to provide an independent check of the absolute differential length calibration (see Figure 1). During eLIGO, re-designed Pcal systems were installed in the X-end stations for both the Hanford (H1) and Livingston (L1) 4k interferometers (see Figure 2). The eLIGO Pcals operated in a two-beam configuration to minimize errors due to sensing the local elastic deformation induced by the radiation pressure. The two beams were positioned on the surface of the End Test Mass (ETM) such that errors due to bulk elastic deformation of the ETM were minimized. The eLIGO Pcals incorporated internal power sensors with temperature-stabilized InGaAs photo-receivers mounted on integrating spheres.

The eLIGO Pcals operated continuously during the S6 science run, injecting a single calibration line in each interferometer with a frequency near 400 Hz. Assessment of the long-term trends in the actuator coefficients was the primary goal of the eLIGO Pcals. Analysis of the Pcal data over all of S6 revealed that the long-term (16 months) stability of the actuation coefficients of the ETM voice-coil actuators was better than 1% (p-p) for both H1 and L1. Furthermore, the Pcals were able to provide absolute calibration of the interferometers’ responses. During S6, the Pcals were also used to make swept sine measurements of the interferometer closed-loop response functions over the frequency band from 70 Hz to 1 kHz.

During aLIGO, the Pcals are expected to play a more prominent role, if not the lead role, in the calibration of the LIGO interferometers. One Pcal system will be installed for each ETM, six Pcal systems in all. Upgrades for aLIGO, as detailed in this document, include more powerful lasers, more rigid support structures, and directing the beams reflected from the ETMs out of the vacuum system to continuously monitor the reflected power.

The scope of the aLIGO Pcals includes:

- Transmitter and receiver modules
- Transmitter pylon (the receiver pylon is shared with, and in the scope of, the Optical Levers subsystem)
- In-vacuum periscopes mounted on compression rings
- Gold Standard and Working Standard laser power sensor systems, including periodic absolute power calibrations at NIST, and the facility and procedures used to transfer the Gold Standard calibration to the Working Standards.

- Electronics, including laser and photo-receiver power supplies, acousto-optic modulator driver, *Optical Follower* servo for control of the modulated waveform, and analog signal conditioning filters.



Figure 1 – iLIGO Photon Calibrator Transmitter Module

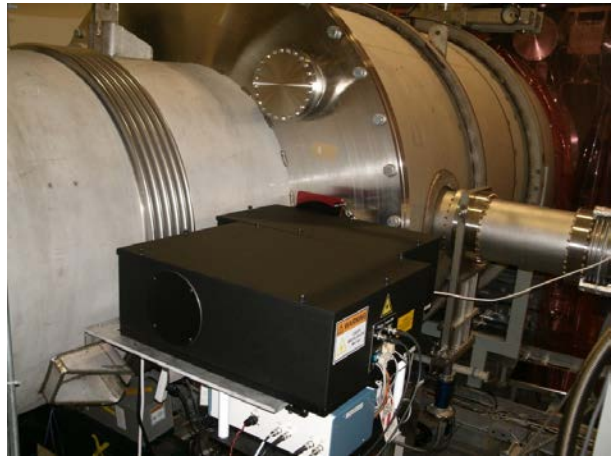

Figure 2 – eLIGO Photon Calibrator Transmitter Module

1.2 Principle of Operation

The Pcal's use power-modulated auxiliary lasers to induce periodic modulations in the position of a suspended ETM via photon radiation pressure, as shown schematically in Figure 3.

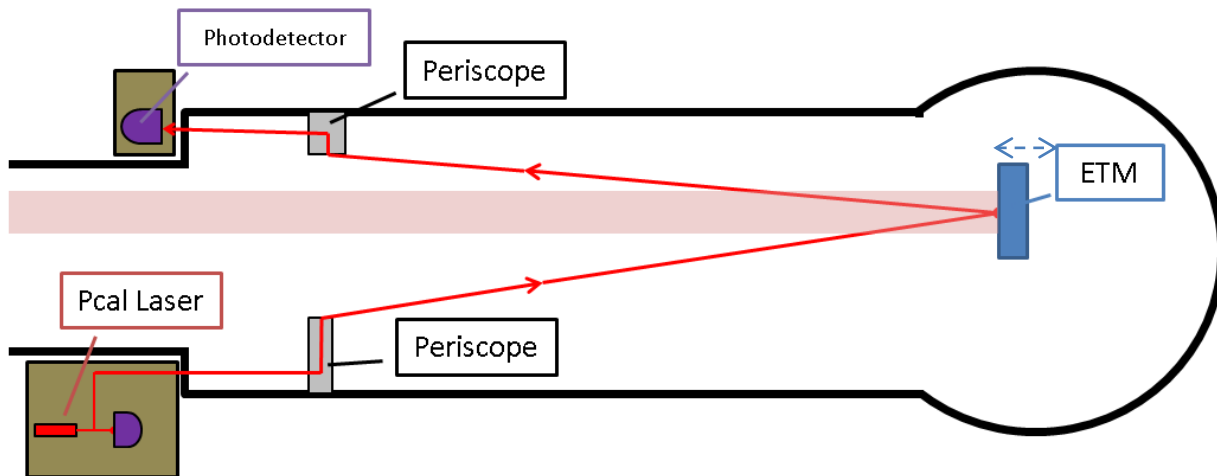

Figure 3 – Basic Schematic of aLIGO Pcal System

For modulation frequencies much higher than the ETM pendulum resonance frequency, the ETM responds as a free mass and its induced displacement is given by (1):

$$x_0 = -\frac{2p_0}{c} \frac{1}{M\omega^2} (\cos \theta) \tag{1}$$

where:

x_0 is the amplitude of the periodic displacement of the ETM

p_0 is the amplitude of the periodic laser power modulation

c is the speed of light in vacuum

M is the mass of the ETM

ω is the angular frequency of the power modulation

θ is the angle of incidence on the ETM

and the minus sign indicates that the induced displacement is 180° out of phase with the driving force.

2 Performance Requirements

This section addresses the key requirements that impact the design of the Photon Calibrators.

2.1 Accuracy of Induced Displacements: Absolute Power Calibration, Beam Positioning on ETM Surface

The sinusoidal Pcal-induced displacements of the ETMs are required to be accurate within 5% in amplitude and $16\mu\text{s}$ in timing over 2σ confidence intervals.

All of the parameters in Equation (1), except for the absolute laser power modulation amplitude, will be known with accuracies sufficient to reduce their contribution to the overall induced displacement error to below 0.1%. Equation (1) does not include contributions to sensed displacements resulting from radiation-induced rotation of the ETMs or elastic deformation of the ETMs (either local or bulk). Accurate positioning of the Pcal beams on the ETM surface can minimize both of these potential sources of calibration errors. We expect that Pcal uncertainties will be dominated by determination of absolute laser power modulation amplitudes (see Section 6). Our experience during iLIGO and eLIGO indicates that absolute laser power calibration at the 1% level (2σ) is achievable with the scheme we propose.

2.1.1 Absolute Power Calibration

Absolute laser power calibration is achieved by transferring the calibration of a *Gold Standard* power sensor that is periodically calibrated at the National Institute of Standards and Technology (NIST) to *Working Standard* power sensors that are used to calibrate power sensors that are located inside the Pcal transmitter and receiver modules, sensing the laser power directed to and reflected from the test masses.

This calibration strategy, which was developed in consultation with Dr. Joshua Hadler at NIST, is shown schematically in Figure 4. It is intended to enable “NIST traceability¹” of the absolute power calibration of the Pcal with overall 2σ uncertainty of less than 5 percent.

¹ NIST defines traceability as “The property of the result of a measurement or the value of a standard whereby it can be related to stated references, usually national or international standards, through an unbroken chain of comparisons, all having stated uncertainties” (http://ts.nist.gov/Traceability/supplmatls/suppl_matls_for_nist_policy_rev.cfm).

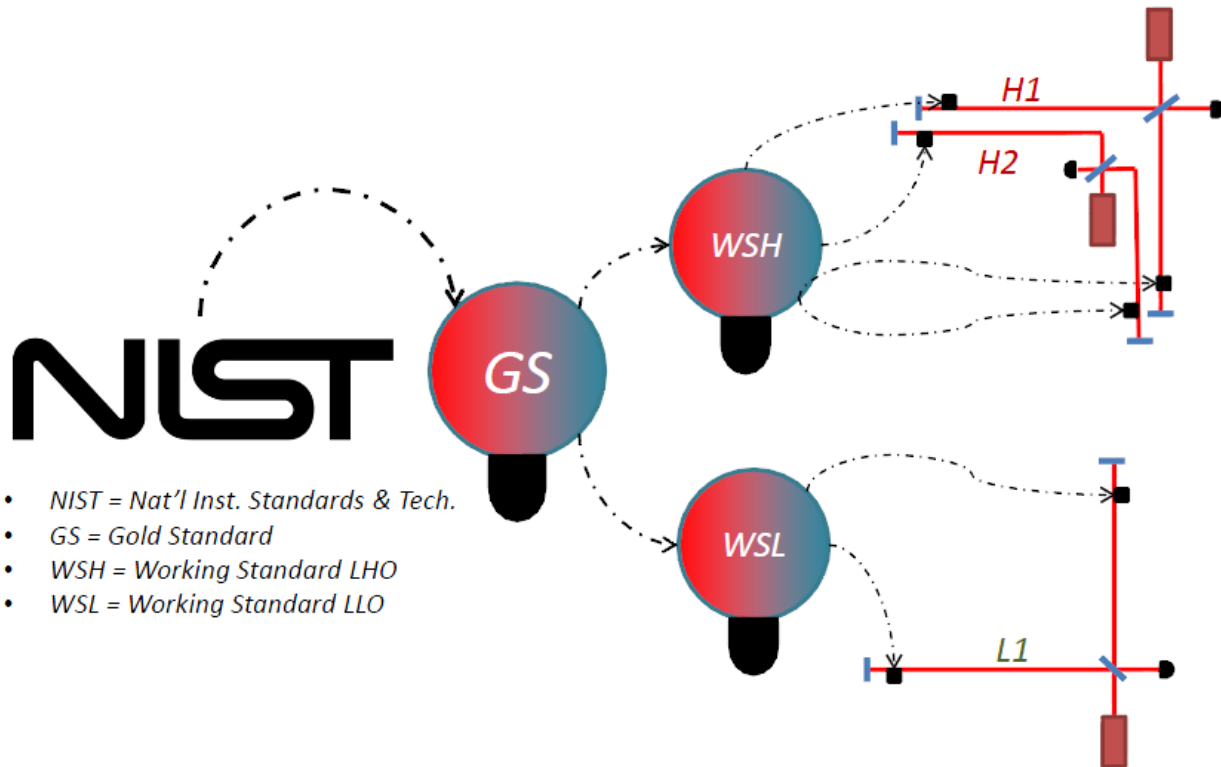

Figure 4 – aLIGO Pcal absolute laser power calibration scheme. Circles represent power calibration standards, black boxes represent Pcal transmitter modules, NIST represents the National Standard Calorimetric Calibration Facility at NIST, and dashed lines represent calibration links.

All of the aLIGO Pcal power sensors are InGaAs photoreceivers mounted on integrating spheres. While these sensors are subject to laser speckle that induces slow uncorrelated variations in their outputs (period of seconds to minutes with amplitudes of a fraction of a percent), they are insensitive to input beam parameters² such as alignment, divergence, polarization, spot size, etc. They have proven to be long-term stable at the 1% level. See Section 6 for a more detailed discussion of the absolute power calibration.

2.1.2 Beam Positioning on ETM Surface

To account for the impact of Pcal-induced rotation of the ETM on the displacement sensed by the interferometer, Equation (1) should be multiplied by the factor

$$\left(1 + \frac{M}{I} \vec{a} \cdot \vec{b}\right) \quad (2)$$

where \vec{a} and \vec{b} are displacement vectors from the center of the face of the ETM to the center of the interferometer beam, and to the center of force for the two Pcal beams, respectively, and I is the moment of inertia about an axis through the center of the ETM and parallel to the face of the optic (see [LIGO-P080118](#)). Even if both displacement vectors are parallel and as large as 1 cm, the

² [LIGO-T1000637](#)

resulting factor for sensing the induced displacement, the rotational factor given by the second term of Equation (2), will be less than 0.01. This term is thus omitted from Equation (1).

Actuation forces applied to the ETMs produce both local_{3,4} and bulk_{5,6} elastic deformations that can significantly alter the interferometer's response, especially when the frequencies of the modulated forces are above 1 kHz. Equation (1), the Photon Calibrator displacement formula, assumes that the ETM moves as an ideal free and rigid mass. However, these elastic deformations would cause the displacement of the surface of the ETM to deviate from the ideal rigid-body motion. The aLIGO ETMs are also unique because of the flats on either side of the ETM which complicate modeling.

H. Pablo Daveloza, using Finite Element Analysis in COMSOL, studied these effects and summarized his results in [LIGO-P1100166](#). He also investigated the optimal number of Pcal beams and the optimal locations of those beams on the surface of the ETM. The main ETM normal modes that would be excited by the Pcal radiation forces are the *butterfly* and *drumhead* modes shown Figure 5.

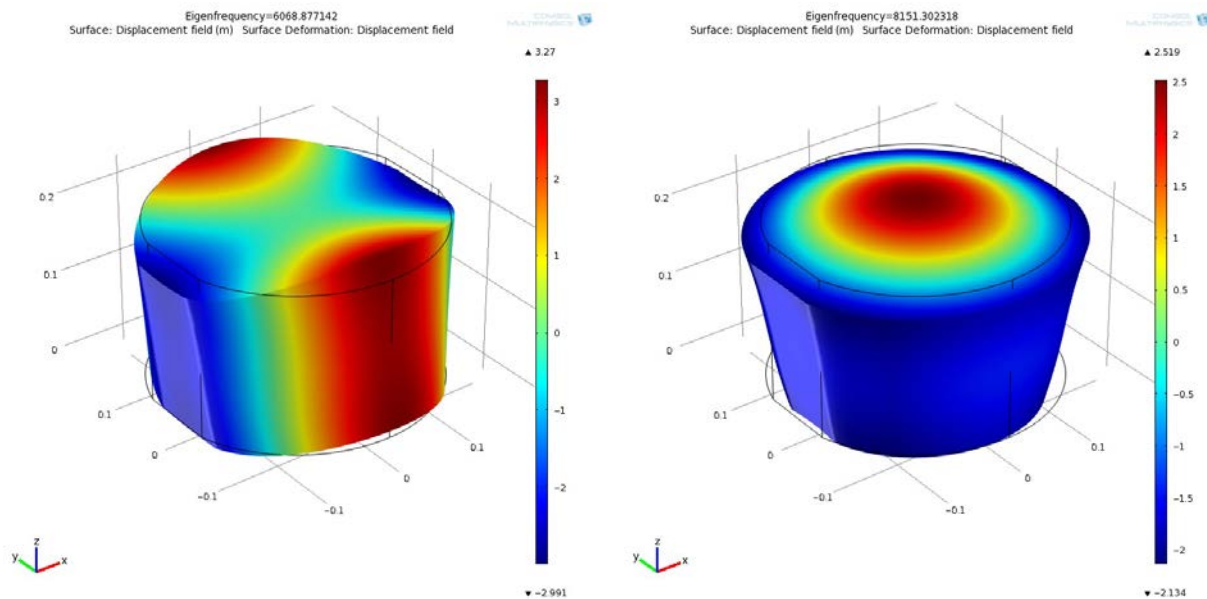

Figure 5 COMSOL simulation of the butterfly mode excited at ~6.1 kHz (left) and the drumhead mode excited at ~8.1 kHz, both for the aLIGO ETM.

The COMSOL modeling revealed that if the two Pcal beams are located optimally the excitation of the drumhead-pattern deformation of the ETM is minimized. For the aLIGO ETMs, the optimum locations are diametrically opposed and 111.6 mm from the center of the ETM as shown in Figure 6.

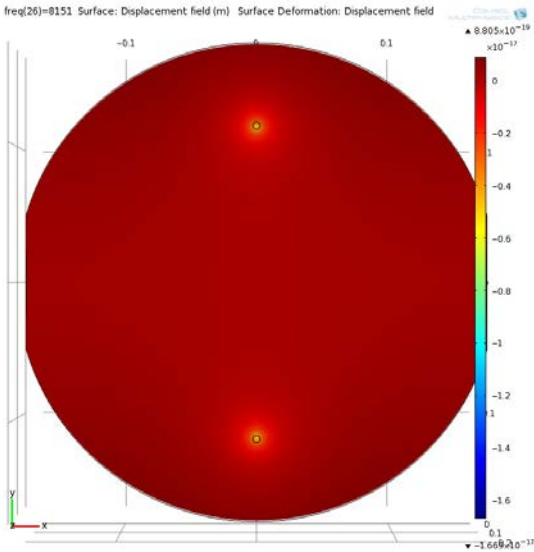

Figure 6 Ideal location of Photon Calibrator beams on ETM surface (111.6 mm from center along vertical diameter).

Optimally-located beams in 3-beam or 4-beam configurations can minimize excitation of the butterfly-pattern deformation as well. However, beam positioning constraints imposed by the folded Arm Cavity Baffles that are part of the Stray Light Control subsystem make the 3-beam and 4-beam configuration impractical. Furthermore, the FEM results showed that unless the beam locations on the ETM surface can be maintained within 1 mm of their optimal locations the 3-beam and 4-beam configurations are no better than the 2-beam configuration.

Figure 7 shows the predicted calibration errors as a function of the displacement of the Pcal beam spots from their optimum locations in a 2-beam configuration.

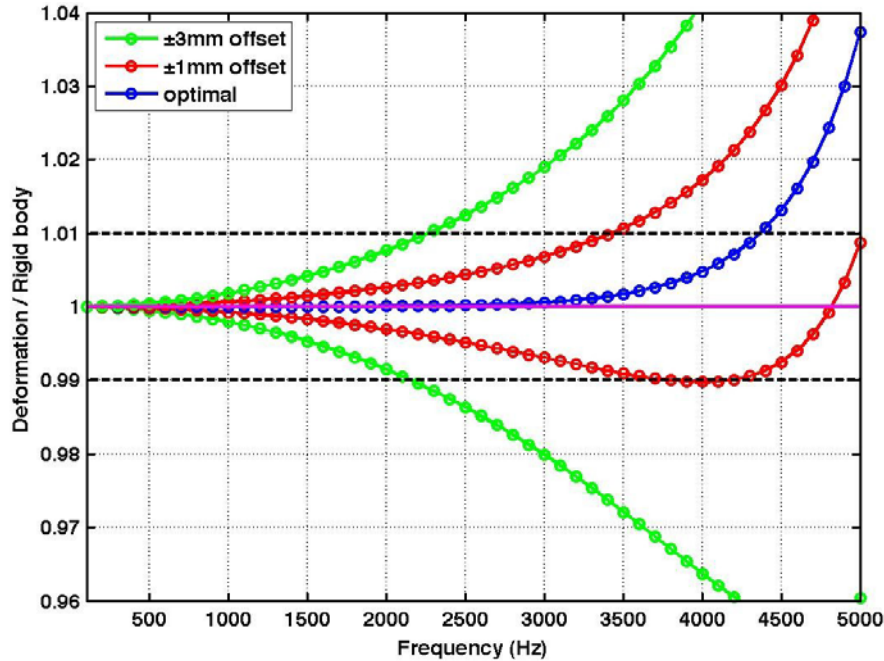

Figure 7 – Errors due to bulk elastic deformation resulting from Pcal beam spots offset from their optimal locations in the 2-beam configuration.

If the beam positions are held within 1 mm of the ideal locations, the calibration errors remain below $\pm 1\%$ for frequencies up to 3.5 kHz. For beam offsets up to 3 mm, the calibration errors are below $\pm 1\%$ up to 2 kHz. Even for optimally-located beam spots, the calibration error reaches 1% at about 4.3 kHz due to excitation of the butterfly-pattern deformation in the 2-beam Pcal configuration.

2.2 Precision of Induced Displacements: Laser Power

As shown in Equation (1), the amplitude of the modulated ETM displacement induced by the Pcals is proportional to the amplitude of the laser power modulation. The Pcals induce sinusoidally-modulated beam powers as shown in Figure 8. A conservative estimate of the amplitude (peak) of the power modulation is $\frac{1}{4}$ of the raw laser power, i.e. the peak-to-peak power modulation is half of the raw laser power. There is also an efficiency factor, ϵ , the Pcal transmitter module optical efficiency in delivering modulated laser power to the ETM. This includes the AOM diffraction efficiency of about 80% and the optical efficiency of the transmitter module optical components (polarizing beam splitter, mirrors, lenses, viewports), conservatively about 80%.

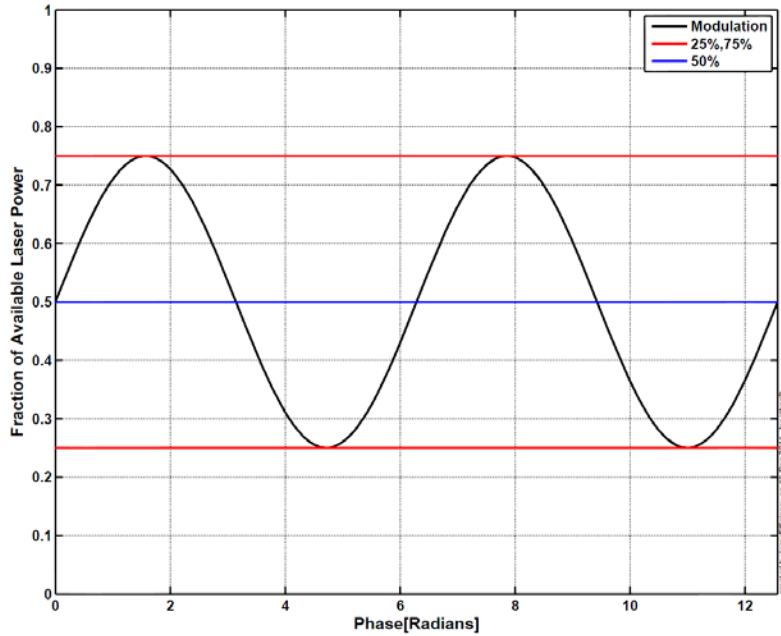

Figure 8 – Pcal power modulation as a fraction of raw laser power for 50% p-p modulation.

Using Equation (1), the total amount of raw Pcal laser power required, P_{laser} , is given by

$$P_{laser} = \sum_i \sqrt{2} L h(f_i) \frac{1}{4\epsilon} \frac{SNR(f_i)}{\sqrt{T_i}} \frac{Mc(2\pi f_i)^2}{2 \cos \theta} \quad (3)$$

where the sum is over the individual modulated displacements with index i and frequency f_i , $h(f_i)$ the is interferometer sensitivity estimate in units of strain (rms) per \sqrt{Hz} (we use the “zero-detuning, high power” and “no SRM” curves published in [LIGO-T0900288](#)), the factor of $\sqrt{2}$ converts the rms strain to peak strain, L is the length of the interferometer arms, the factor of $1/4$ is for 50% p-p modulation as discussed above, ϵ is the transmitter module optical efficiency, $SNR(f_i)$ is the desired signal-to-noise ratio of a given reference displacement, and T_i is the length of the DFT for evaluation of a given periodic displacement.

The raw Pcal laser power required for the various reference displacements, given by Equation (3), are listed in Table 1 in the “Pcal Laser Power” columns and shown graphically in Figure 9. The table also includes the amplitudes of the reference displacements.

Table 1 – Raw laser power requirements for Pcal reference displacements³

<i>aLIGO Sensitivity Curve</i> →	<i>Zero-Detuning, High Power</i>	<i>No SRM (25W Power)</i>
----------------------------------	----------------------------------	---------------------------

³ Calibration SVN:

<https://svn.ligo.caltech.edu/svn/calibration/trunk/calibration/frequencydomain/runs/S6/PhotonCalibrator/measurements/aLIGOSTudies/rpnStudies/sensitivity.m>

<i>Frequency</i>	<i>DFT length</i>	<i>SNR</i>	<i>Displacement</i> $(\frac{\text{meters}_{RMS}}{\sqrt{Hz}})$	<i>Pcal Laser Power</i>	<i>Displacement</i>	<i>Pcal Power</i>
50 Hz	1 second	20	4.02×10^{-19}	2.73 mW	3.99×10^{-19}	2.70 mW
400 Hz	1 second	20	3.07×10^{-19}	0.134 W	1.35×10^{-18}	0.584 W
1,100 Hz	1 second	20	4.60×10^{-19}	1.51 W	3.66×10^{-18}	12.0 W
2,000 Hz	60 second	10	3.67×10^{-19}	0.515 W	3.32×10^{-18}	4.65 W
				Total Pcal Power		17.2 W

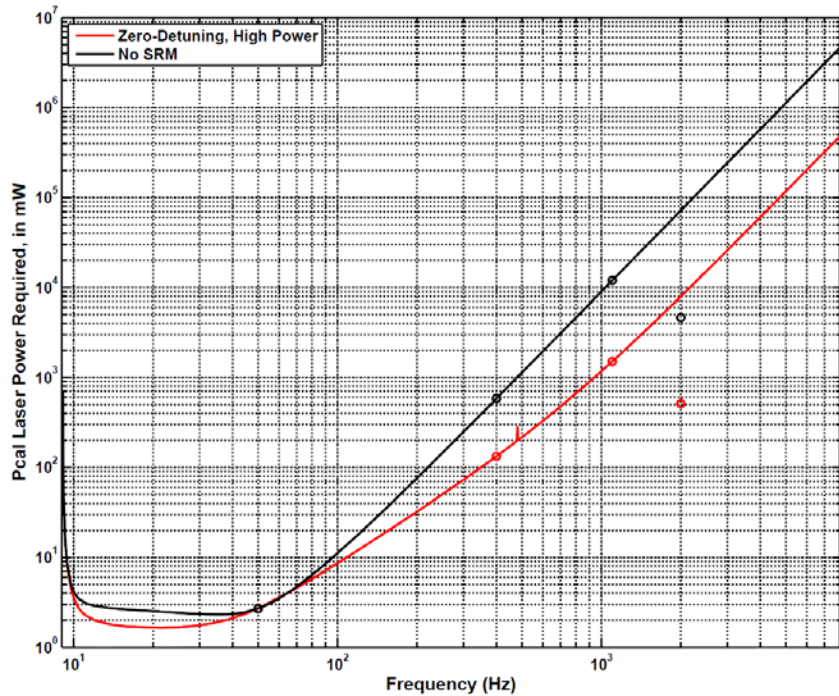

Figure 9 –Required laser power as a function of frequency for two aLIGO interferometer configurations. Circles represent reference displacements. The two circles at 2 kHz are reduced from their respective curves by $2\sqrt{60}$, reflecting their lower SNR and longer DFT time as shown in column 2 of Table 1.

Table 1 shows that as frequency increases, the required Pcal laser power increases rapidly. To maintain reasonable Pcal laser powers, the highest calibration line, which is placed beyond the UGF of the DARM servo, only requires an SNR of 10 for 60-second-long DFTs.

Note that other configurations for the Pcal excitations might also be utilized for aLIGO calibration studies. For instance, the Pcal on the two interferometer ETMs can excite excitations in differential mode, enabling twice the differential displacement excitation of a single Pcal module. Or, the two Pcal modules could operate in common mode, inducing a large common-mode excitation with minimal differential mode excitation. Observation of a peak in the differential length spectrum (or the lack thereof) would indicate a change (or lack of change) in the differential actuation of the DARM servo.

2.3 Displacement Noise: Relative Power Noise and Harmonic Noise

The amplitude spectral density of the displacement noise from Pcal, other than intentional reference displacements, shall not exceed 10% of the design sensitivity for the interferometer. We use the “zero-detuning, high power” sensitivity curve for this requirement ([LIGO-T0900288](#)).

There are two sources of displacement noise from the Pcal: inherent relative power noise from the laser (RPN) and noise introduced at harmonics of the modulation frequency due to nonlinearity of the power modulation process.

The maximum allowed displacement due to RPN is given by

$$\Delta x_{max} = 2\Delta P_{max} \cos\theta / (Mc\omega^2) = Lh(f)/10 \quad (4)$$

The average power incident on the ETM is $\epsilon P_{laser}/2$, so the maximum laser RPN is given by

$$RPN_{max} = \Delta P / (P_{laser}\epsilon/2) = \frac{Lh(f)Mc\omega^2}{10 \cos\theta P_{laser}\epsilon} \quad (5)$$

The maximum allowable RPN for two aLIGO sensitivity curves, the “no SRM” and the “zero-detuning, high power” configurations, and assuming the raw laser powers given in Table 1 (2.16 W and 17.2 W, respectively), are plotted in Figure 10. Also plotted for comparison are the measured RPN of two candidate lasers, a 500 mW unit sold by CrystaLaser and a 500 mW microFlare laser sold by InnoLight. Both lasers were scaled to the higher power levels assuming that the RPN of the lasers would stay the same.

The “no SRM” curve is shown for comparison only; we don’t intend to procure 17 W lasers for the Pcal. Note, however, that because the Pcal will use lasers with only about 2 W output power the SNR for the Pcal reference displacement lines achievable in the “no SRM” mode will be significantly lower.

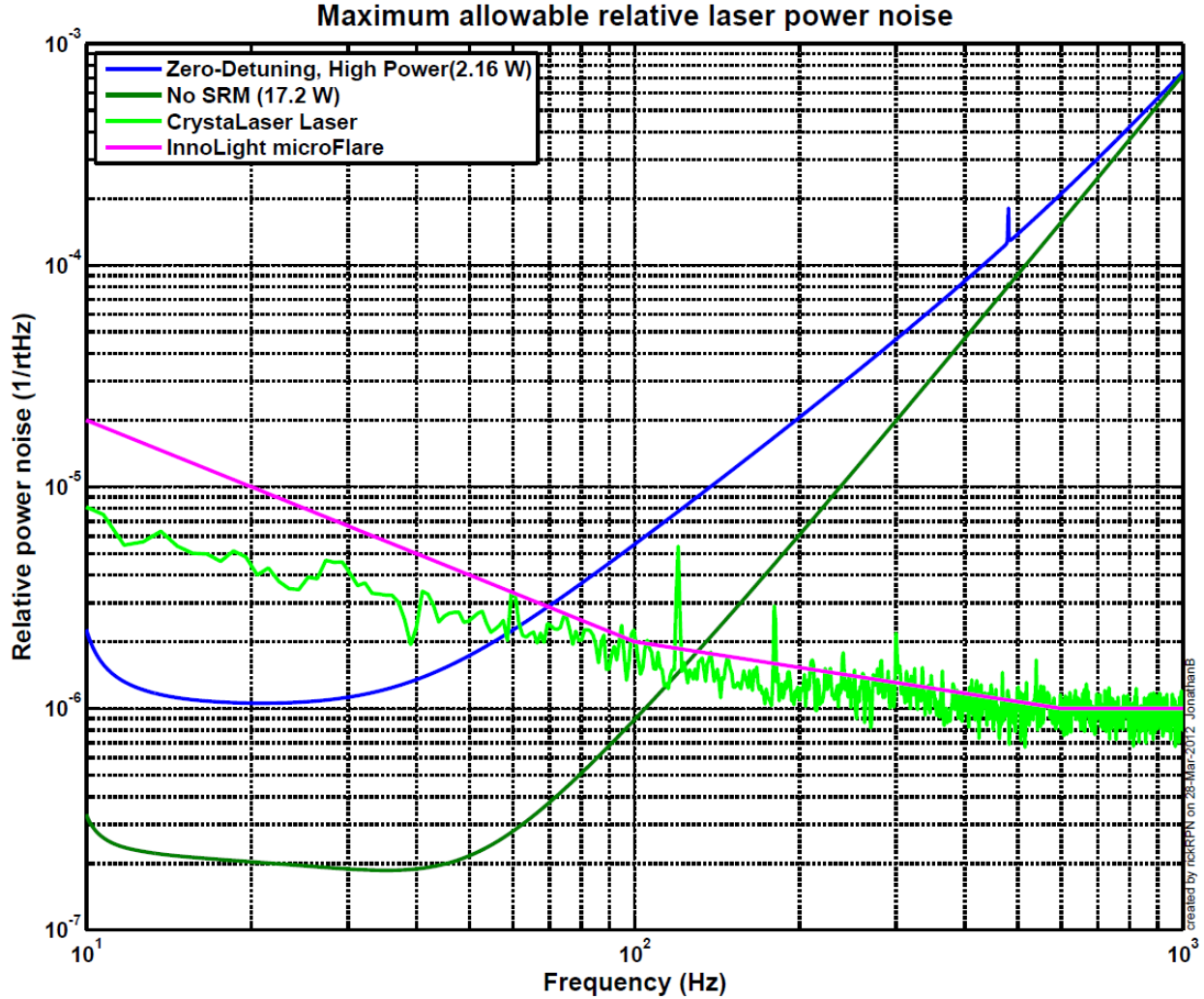

Figure 10 – RPN requirement for two sensitivity curves and measured RPN of two laser systems.

Displacement noise induced at harmonics of the Pcal modulation frequencies is required to be at least a factor of 10 below the anticipated displacement sensitivity. However, the amplitudes of the displacements induced by power fluctuations decrease with the square of the modulation frequency. Thus the requirement for the ASD of the laser power spectrum for harmonics is given by

$$\frac{\Delta P(nf_0)}{\Delta P(f_0)} = \frac{n^2}{10 \text{ SNR}} \frac{h(nf_0)}{h(f_0)} \quad (6)$$

where SNR is the signal to noise ratio of the injected modulation at frequency f_0 with respect to the strain sensitivity curve $h(f_0)$ and n is the ratio of the harmonic frequency to that of the fundamental. Equation (6) is plotted in Figure 11 for the first three harmonics and for both the “zero detuning, high power” and “no SRM” configurations.

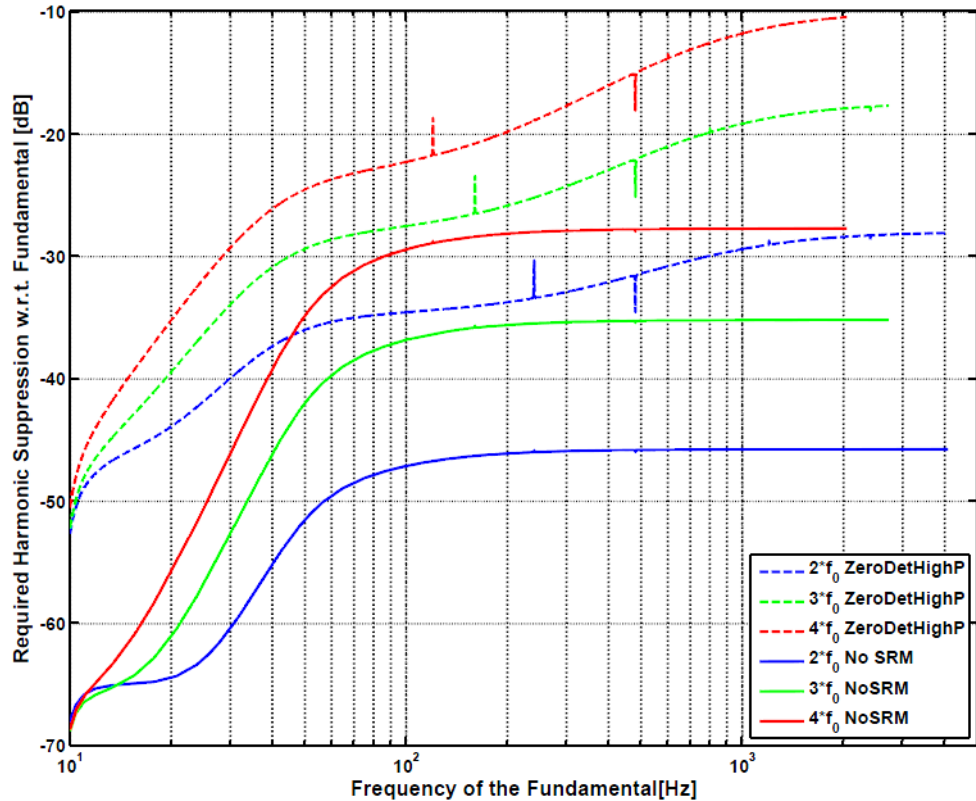

Figure 11 – Maximum allowable relative harmonic noise for the first four multiples of the frequency of the fundamental for both the “no SRM” and “zero-detuning, high power” configurations.

Suppressing both the power modulation at harmonics of the Pcal fundamental frequencies and inherent laser power fluctuations will require a power stabilization servo. We refer to this servo as the *Optical Follower* servo because we intend to inject the desired sinusoidal waveforms at the error point of the servo so that the servo will impress these waveforms on the modulated output power. See “Overview of Photon Calibrator Electronics” ([LIGO-T1100556](#)) for a more detailed discussion of this noise suppression servo.

2.4 UTC Synchronization

All excitations shall be independently and directly synchronized to UTC via GPS. See “Overview of Photon Calibrator Electronics” ([LIGO-T1100556](#)) for a full discussion of timing synchronization with UTC.

2.5 Laser Wavelength

There are two criteria for choosing the wavelength of the Photon Calibrator laser. First, the wavelength must be sufficiently distant from the interferometer laser wavelength to prevent noise from scattered light coupling into the interferometer signals. We assume that the wavelengths must be separated by at least 0.3 nm to be outside the nominal tuning range of the NPROs that dictate the frequencies of the aLIGO PSLs. Second, we want to maintain high reflectivity on the HR coatings of the ETMs.

2.6 Continuous Excitation lines

Each Pcal shall operate continuously, simultaneously inducing periodic displacements of the ETMs at several frequencies. See “Overview of Photon Calibrator Electronics” ([LIGO-T1100556](#)) for a detailed discussion of how these excitations are implemented.

2.7 Swept-Sine Measurements

The Pcal shall be capable of performing swept sine measurements of the interferometer length response from 10 Hz to 1 kHz in less than 1 hour with coherence of 99% or better using CDS software.

2.8 Reliability

Mean Time Between Failures (MTBF) for out-of-vacuum components, including lasers and electronics, shall be at least 10,000 hours. The Pcal do not include active in-chamber components. See Section 8, “Failure Modes and Hazards,” for a discussion of the reliability of the Pcal.

3 In-Vacuum Systems: Beam Paths and Periscopes

For aLIGO, the main interferometer beams will be situated as shown in Figure 12. The ETMs are displaced by 20 cm horizontally to either side of the beam tube centerline and sit 8 cm below it. Because of the locations of the Optical Lever vacuum windows and receiver pylons, the Pcal transmitter pylons are located such that the Pcal transmit across the beam tube centerlines to reach the ETMs. Figure 13 shows the location of the Pcal and Optical Lever pylons for the L1 Y-end, which is typical of all end stations.

Extract from L0900059-v1
 D0901477-v1
 Hanford, Washington

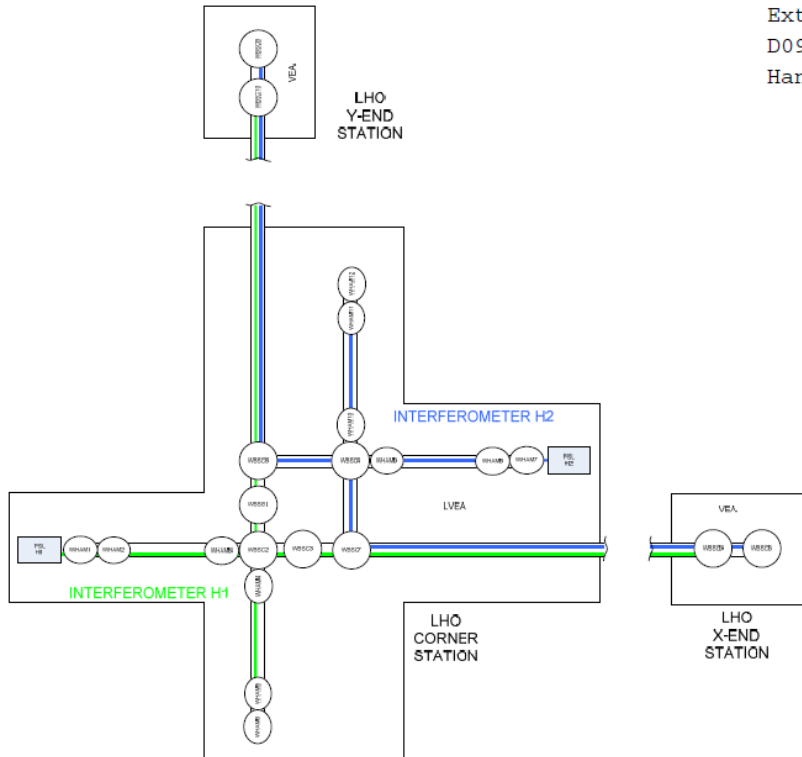

Figure 12 – LHO (H1 and H2) Beam Layout. The H2 beams are to the inside of the beam tubes and do not cross the H1 beams ([LIGO-D0901477-v2](#)).

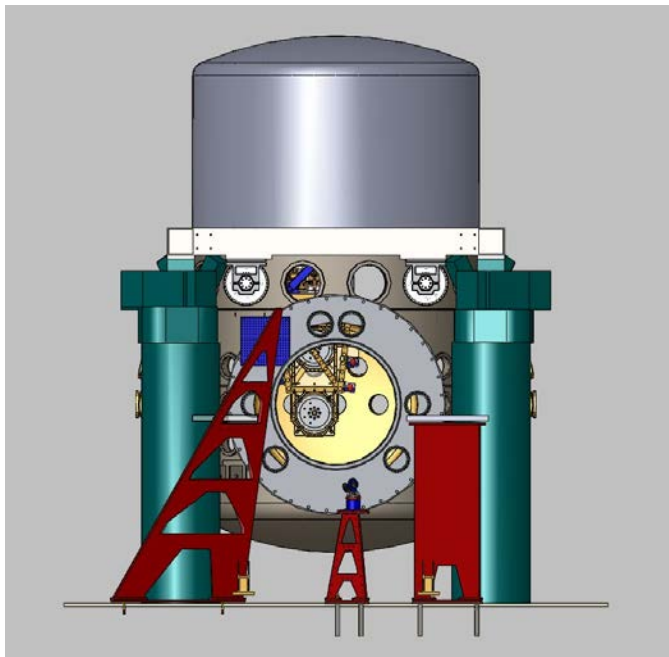

Figure 13 – View of L1 ETMY, looking from the corner station. The Pcal transmitter pylon is on the right with the short Optical Lever transmitter pylon in the middle and the tall Optical Lever receiver pylon (which also houses the Pcal receiver module) shown on the left.

The “handedness” of the six Pcal configurations is tabulated in Table 2. The layout of the Pcal transmitter module has been designed to easily switch between a right-handed and left-handed configuration by simply rotating two mirror mounts.

Table 2 – Handedness of Pcal modules, facing the HR surface of the ETM

Interferometer	Arm	Transmit side	Receive side	DCC#
H1	X	L	R	D0901468
	Y	R	L	D0901467
H2	X	R	L	D0901468
	Y	L	R	D0901467
L1	X	L	R	D0901465
	Y	R	L	D0901464

3.1 Beam Paths and Periscopes

To achieve the required accuracy for the aLIGO Pcal, the Pcal beams must be precisely located on the ETMs at positions that minimize bulk elastic deformation of the ETMs. In aLIGO, folded Arm Cavity Baffles, with apertures just 4 mm in diameter larger than that of the ETM, are located upstream of the ETMs. These baffles preclude directing the Pcal beams directly onto the surfaces of the ETMs. The aLIGO Pcal thus use input periscopes that direct the Pcal beam toward the axis of the beam tubes to decrease the angle of incidence on the ETMs and reduce interference with the Arm Cavity Baffles. In addition, for aLIGO the Pcal beams that reflect from the ETMs will be collected by in-vacuum periscopes and directed out of the vacuum system for continuous monitoring. This is in contrast to the iLIGO and eLIGO systems, which just let the reflected beams scatter off of the walls of the beam tube manifolds. Collecting the reflected beams will enable monitoring of the optical efficiency from the transmitter module output to the power reflected from the ETM and obviate the need for the in-chamber measurements that have proven necessary at the ends of the S5 and S6 science runs.

The in-vacuum periscopes will be mounted on a single compression ring that is similar to the design that the AOS system uses to mount baffles inside the beam tube manifolds.

Two baffles are positioned between the Pcal viewports and the ETMs (see [LIGO-T0900269](#) for more information). For H1 and L1, they are the Cryopump Baffle, shown in Figure 14, and the Arm Cavity Baffle, shown in Figure 15. For H2, they are the flat, Manifold Baffle and the Arm Cavity Baffle.

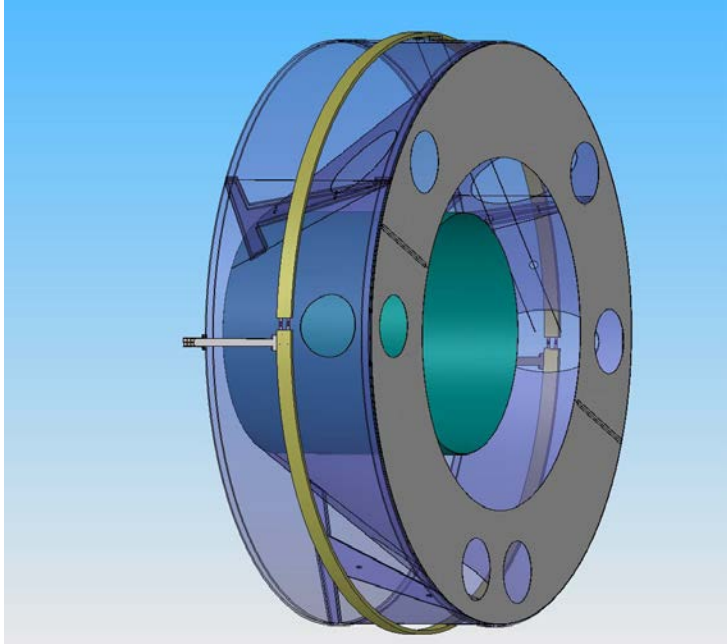

Figure 14 – Cryopump baffle positioned near viewports of H1 and L1. Holes in the baffle allow for Pcal beams, Optical Lever beams, and cameras to have access to the ETM.

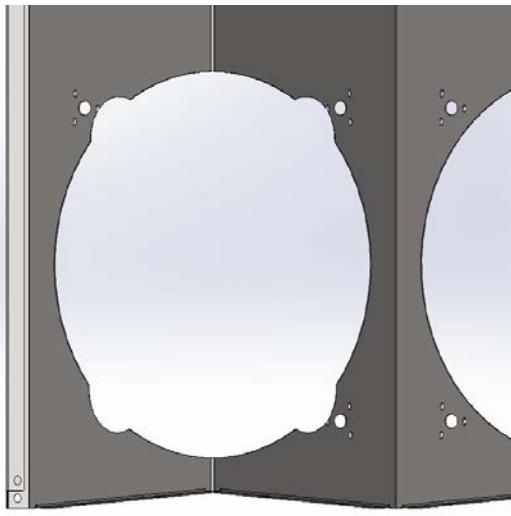

Figure 15 – Arm cavity baffle that is positioned in front of each ETM. The four “mouse ear” cutouts provide minimal clearance for the two Pcal beams.

A bird's-eye view of the LHO Y-end Pcal beam paths is shown in Figure 16.

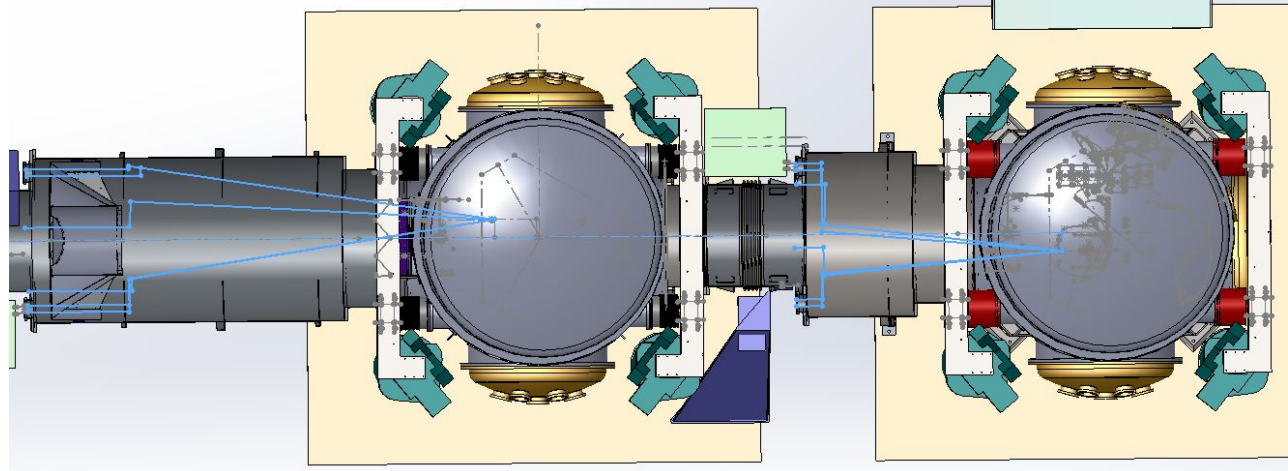

Figure 16 – Optical layout of both H1 (left) and H2 (right) at the Y-End Station. The lime green rectangles are the Pcal transmitter modules and the purple rectangles are the Pcal receiver modules that are mounted in the Optical Lever receiver pylons.

3.1.1 H1 and L1

Figure 18 illustrates the in-vacuum beam paths for the H1 and L1 Pcal. Two horizontal beams leave the transmitter module and use in-vacuum periscopes to reach the ETM. All Pcal inject two beams that are horizontally displaced by 1.5” to either side of the center of the Pcal viewport. Both beams are vertically displaced by 1.24” above the viewport centerline such that the beam that will be directed to the upper spot on the ETM propagates horizontally from transmitter to receiver modules. The other beam, the beam that starts farthest from the beam tube manifold centerline, is directed down by an input periscope, then propagates horizontally to the ETM and the receiving periscope which directs it back up to the level of the upper beam (1.24” above the viewport centerline) and out of the vacuum system. All Pcal beams, input and output, propagate into and out of the vacuum system parallel to the beam tube centerline to or from the in-vacuum periscopes (see Figure 17).

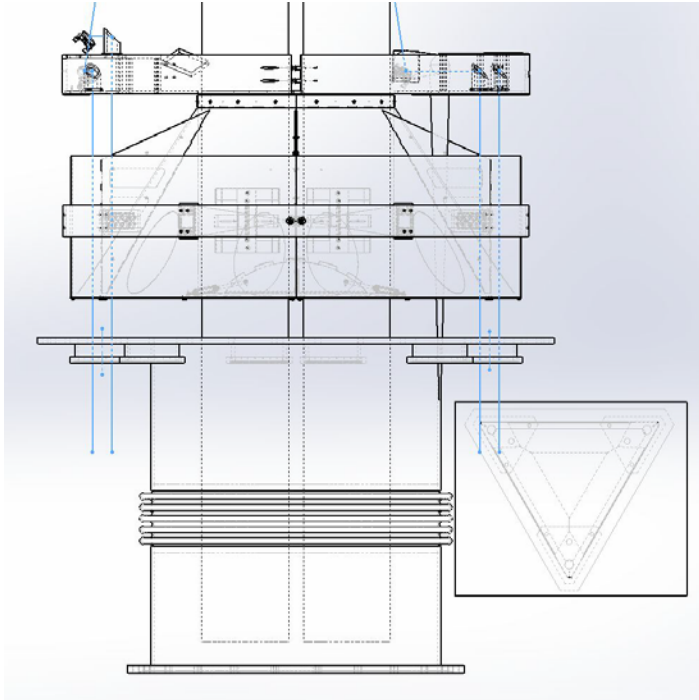

Figure 17 – H1Y Pcal beams (blue) entering from right and exiting from left WBSC10 at Y-End Station, from a bird's-eye view. The square in the lower-right of the figure is the Pcal transmitter module, and the enclosed triangle is the transmitter pylon.

All in-vacuum mirrors are 2" in diameter with HR coatings for 45 deg. incidence. All turning mirrors are in fixed mounts, with only azimuthal and a slight pitch adjustment, except the four periscope mirrors closest to the ETMs (one for each input beam and one for each output beam) that will utilize the standard aLIGO Siskiyou adjustable mounts.

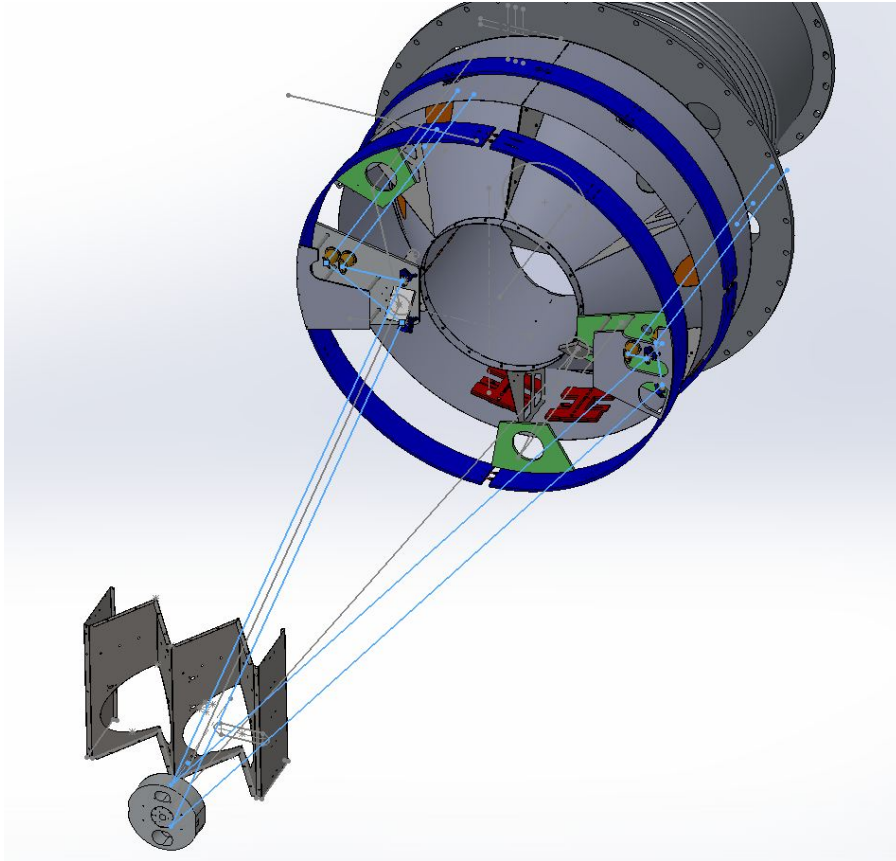

Figure 18 – In-Vacuum Beam Path (blue) of H1, L1 Photon Calibrator Beams with Pcal Periscopes mounted to a compression ring (dark blue).

3.1.2 H2

Figure 19 shows the Pcal beam paths for an H2 ETM. Because of the shorter vacuum manifold, the viewports see the ETM from a wider angle. Because of the Arm Cavity Baffle, neither viewport can see the ETM directly. Because there is only one interferometer beam dictating a Stay-Clear Zone at this location, a crossbeam structure, mounted to a compression ring will be used to support the periscope mirrors. This should simplify pre-alignment and give better structural rigidity.

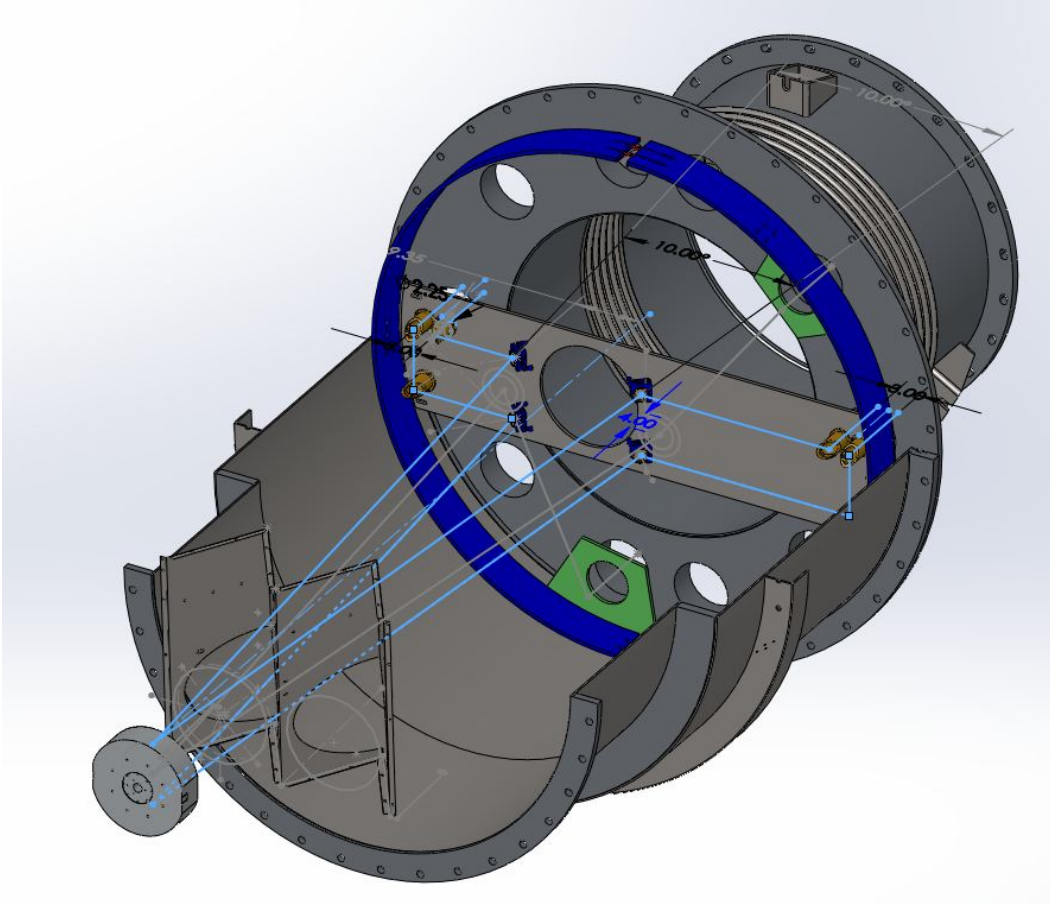

Figure 19 – H2 beam path (blue) and in-vacuum periscopes mounted to a compression ring (dark blue). In this image, the beams launch from the right.

3.2 Beam Alignment and Localization

For iLIGO and eLIGO, the Pcal beams were aligned and located by viewing the light scattered from the ETM by the ETM cameras. The light emitted by the OSEMs was used for alignment fiducials and the HR surface of the ETM scattered enough of the Pcal light that the beam spots could be seen, as shown in Figure 20.

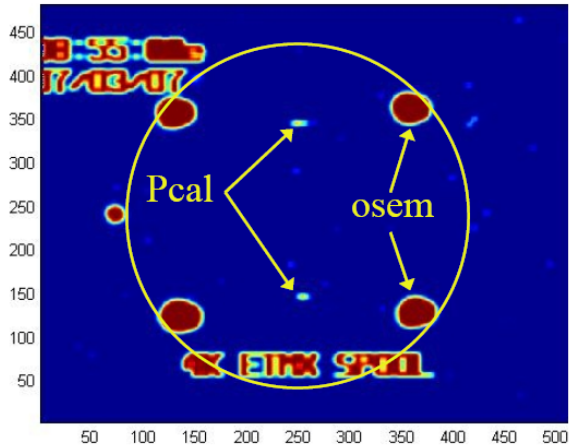

Figure 20 – BSC chamber camera view of ETMX showing the light from the OSEMs as well as the light scattered from the two photon calibrator beams.

For aLIGO, the Pcal lasers will be a factor of four more powerful, but we expect the ETM surfaces to scatter less light. Furthermore, we are striving for better localization of the Pcal beams on the ETM surfaces, ± 1 mm accuracy.

3.2.1 Initial Alignment

The fold mirrors and periscope assemblies will be pre-aligned in the optics labs at the observatory sites before installation in the vacuum envelopes. Then, the beam paths will be pre-aligned using the IAS target, or a similar target (see Figure 22) mounted to the ETM suspension frame as shown in Figure 21, to roughly locate the beams on the ETM surface by adjusting the final turning mirrors on the input periscopes.

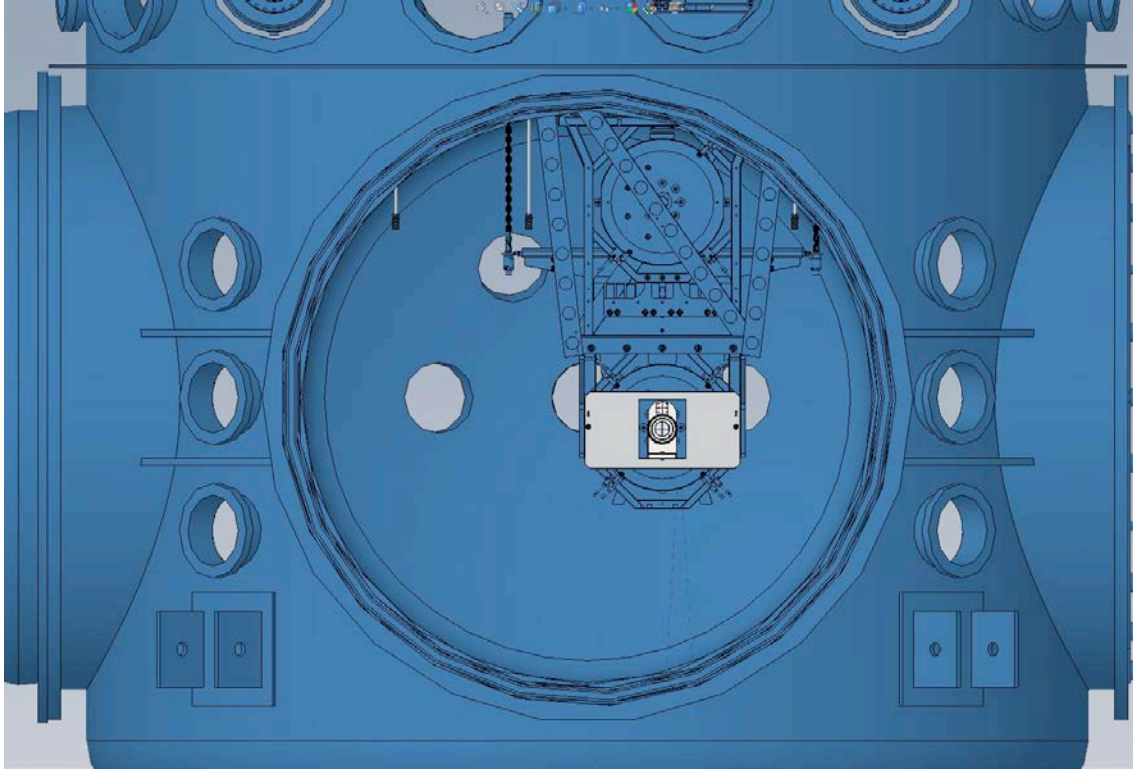

Figure 21 – IAS target mounted ETM suspension frame in BSC6 ([LIGO-D1002497](#))

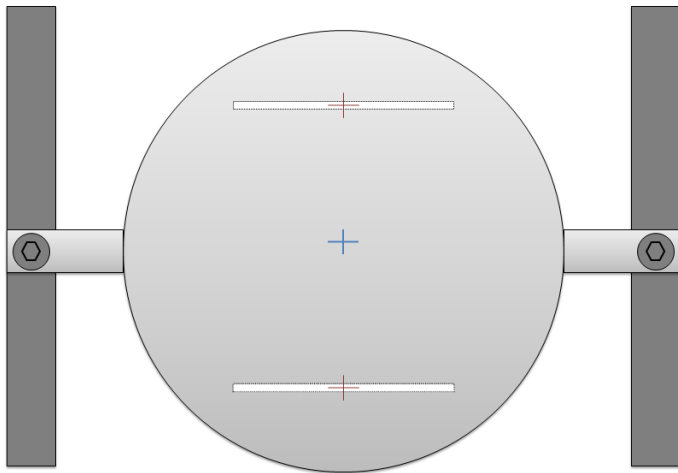

Figure 22 – Concept for Pcal alignment target. The blue crosshair marks the center of the ETM as determined by IAS, and the red crosshairs marks the optimal points of incidence of the Pcal beams, 11.16mm from the center of the ETM along the vertical diameter.

The first contact will then temporarily be partially peeled back to reveal about 7 cm of the ETM surface at the top and bottom of the optic and the Pcal beams reflected from the ETM will be aligned using the first turning mirrors in the output periscopes.

3.2.2 Final Alignment

Pablo Daveloza, as part of his doctoral dissertation at the University of Texas at Brownsville, is designing a Pcal beam localization system capable of determining the position of the Pcal (and

interferometer) beams on the ETM surface with an absolute accuracy of ± 1 mm. This system will likely utilize the ETM CCD camera views provided by the AOS system. The current design calls for the relay mirrors (periscopes – the camera views are also occluded by the Arm Cavity Baffles, so they require periscopes similar to those for the Pcal's but with larger optics) for these cameras to be mounted to the same compression rings used for the Pcal periscopes.

4 Transmitter Module

The transmitter module includes the laser, AOM, internal power sensor, and optical components necessary to generate the two power-modulated Pcal beams. All components are mounted on a 2" thick breadboard that will be mounted to the Pcal transmitter pylon, with a flexible bellows connecting its output aperture to the aperture of the viewport protector assembly. A schematic diagram of the optical configuration of the transmitter module is shown in Figure 23.

aLIGO Pcal Transmitter Module: LIGO-D1102196-V8

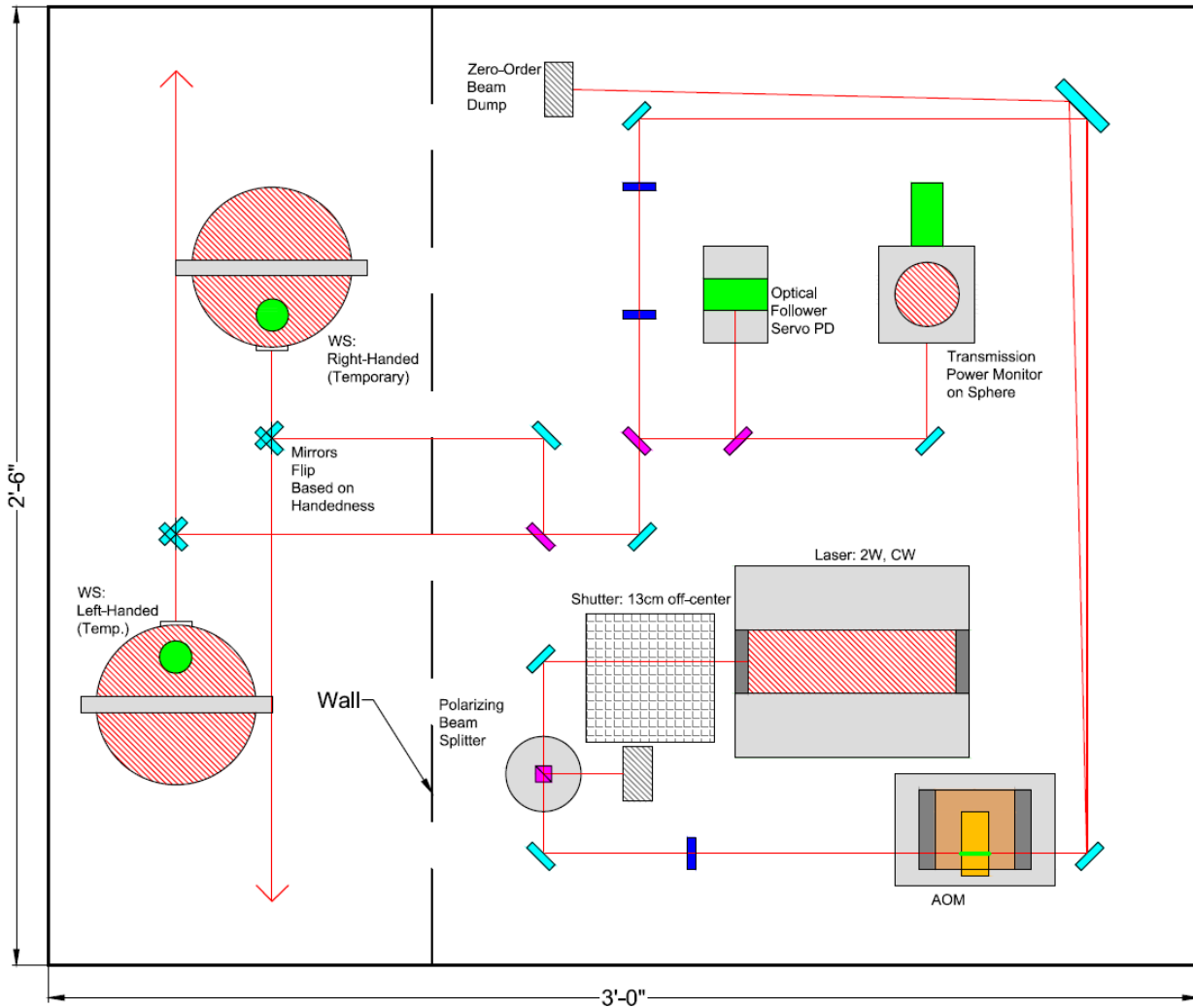

Figure 23 – Schematic of Pcal transmitter module optical components ([LIGO-D1102196](#)).

4.1 Laser

Each transmitter module will contain a laser. The laser will be a 2W, continuous wave, 1047 nm Nd:YLF laser. This wavelength was chosen because it continues the calibration history of the Gold Standard and Working Standard from NIST which used 1047 nm light as well. The laser will be in continuous operation during a science run. The

The aLIGO Pcal transmitter modules will also contain a remote-controlled mechanical laser shutter. Additionally, a feature of eLIGO that will be reused in aLIGO is a slow channel interface that allows the laser power to be turned on or off as necessary, remotely. See “Overview of Photon Calibrator Electronics” ([LIGO-T1100556](#)) for details.

4.2 Acousto-Optic Modulator

During iLIGO and eLIGO, the Pcal used ISOMET 1205C-843 AOMs and ISOMET 230 Series Analog RF Drivers. This RF driver model was discontinued so the ISOMET 532C-2-B, which includes a voltage bias adjust, will be used instead. We will use the ISOMET 1205C-843 modulators for aLIGO

Control of the input signal into the AOM is discussed in “Overview of Photon Calibrator Electronics” ([LIGO-T1100556](#)).

4.3 Internal Laser Power Sensors

The aLIGO Pcal use internal power sensors in both the transmitter modules and the receiver modules to continuously monitor the modulated power waveform. These power sensors use InGaAs photodetectors with integrated pre-amplifiers that are mounted to 2” diameter integrating spheres (see Figure 24). These are similar to the power sensors that were used in the eLIGO Pcal and found to be extremely stable (with a fraction of 1% over 18 months).

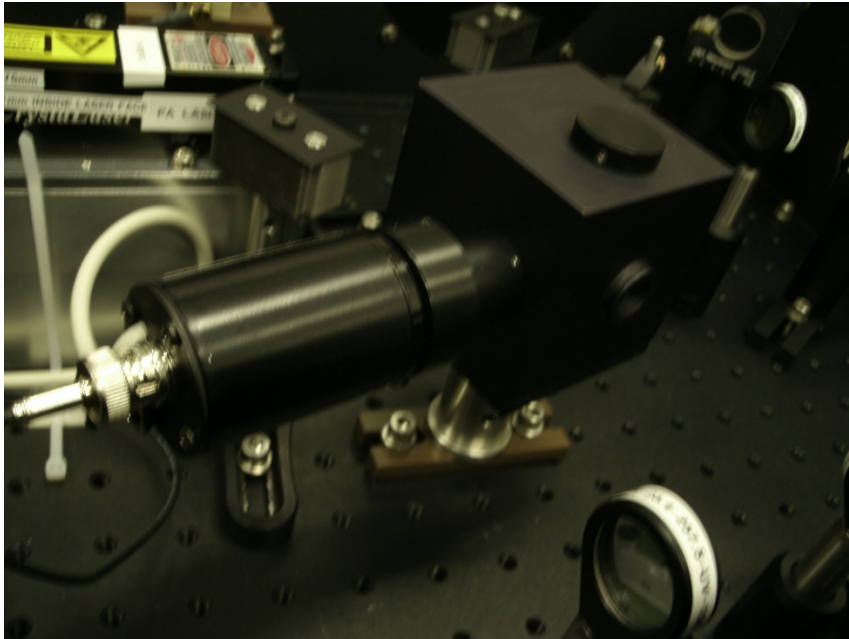

Figure 24 – eLIGO Internal Photodetector’s Integrating Sphere

The internal power sensors will be directly calibrated by one of the Working Standards (see Section 6).

4.4 Physical and Environmental Monitors

A temperature sensor will be installed within the Pcal transmitter module enclosure to facilitate investigations of correlations with temperature variations and to give advance warning of changes in internal conditions.

4.5 Breadboard

The Pcal transmitter module will incorporate a 36" x 30" x 2" thick optical breadboard with ¼"-20 tapped holes on 1" centers.

4.6 Enclosures

The beam path of the Pcals will be entirely enclosed to ensure the safety personnel inside the VEAs and the integrity of the calibration. Both the transmitter and receiver modules will be completely enclosed with painted sheet metal enclosures similar to what was used for eLIGO (see Figure 25).

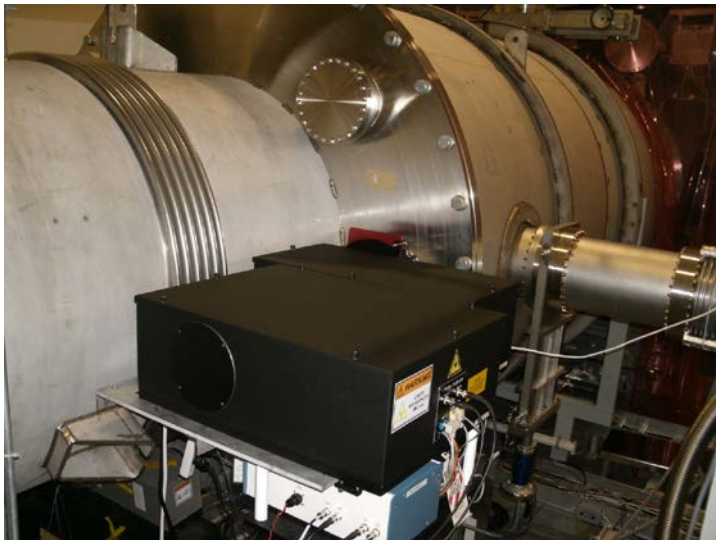

Figure 25 – eLIGO Pcal transmitter module.

4.7 Viewport Protectors

Viewport protectors, provided by AOS, will be installed on both the transmitter and receiver viewports. These protect the viewport glass when work is ongoing inside the Pcal module enclosures.

4.8 Transmitter Module Pylon

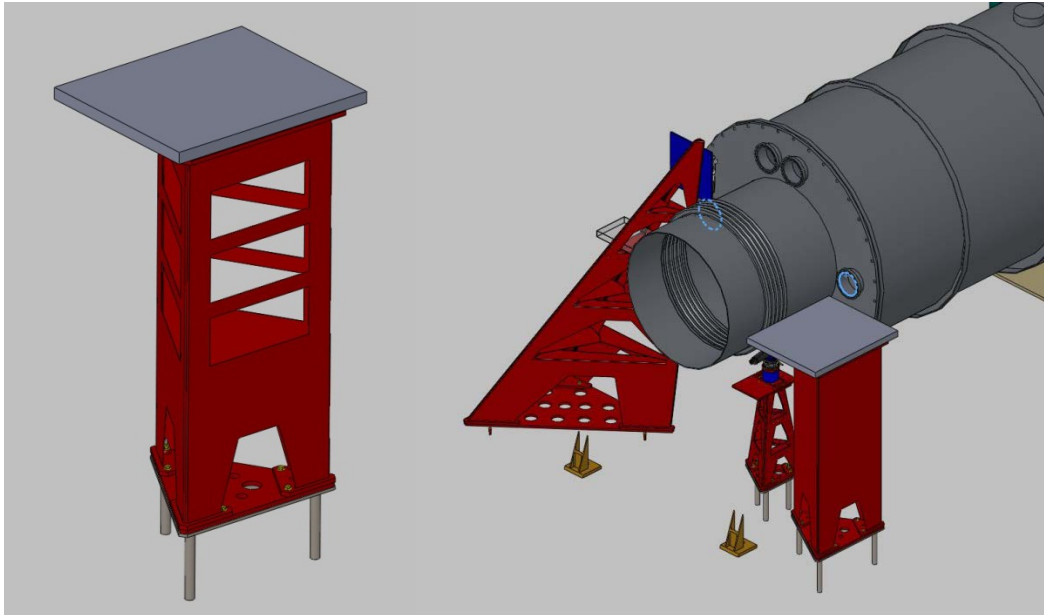

Figure 26 – Solidworks design of Pcal transmitter module pylon with breadboard shown in gray (left). The locations of the Pcal and Optical Lever pylons are shown in the view on the right. Note that the Pcal receiver module breadboard can be seen mounted in the tall Optical Lever receiver pylon.

The transmitter module pylons are composed of 306 stainless steel sheet that is folded and welded in the manner developed for the Optical Lever pylons. The rectangular openings are sized to allow mounting of the Pcal electronics in 19" rack format, if desired. The laser power supply may require mounting in close proximity to the laser and the other electronic components may be mounted in the pylon for convenience. The base of the pylon will be bolted to a grout plate that will be leveled, then bolted and grouted to the floor of the VEA. The pylon and breadboard can be seen in plan view in Figure 17.

Electronics modules, fitting the 19" standard, will be mounted within the slits of the transmitter pylon. These include power supplies for transmitter and receiver module components, signal conditioning boxes, and an AOM driver.

5 Photon Calibrator Receiver Module

The aLIGO Pcal will also measure the power of the Pcal laser beams downstream of the ETM – outside the vacuum envelope, inside the Pcal receiver module. The both beams are directed to a single power sensor. The receiver module has enough space to accommodate a Working Standard for absolute power calibration.

5.1 Internal Power Sensor

The receiver module internal power sensor will be similar to the power sensor used for the transmitter module. The two Pcal beams will be directed into the entrance aperture of the power sensor's integrating sphere at near-normal incidence. The receiver module will also contain a mirror

on a removable kinematic stage to accommodate the Working Standard for calibration measurements (see Figure 27).

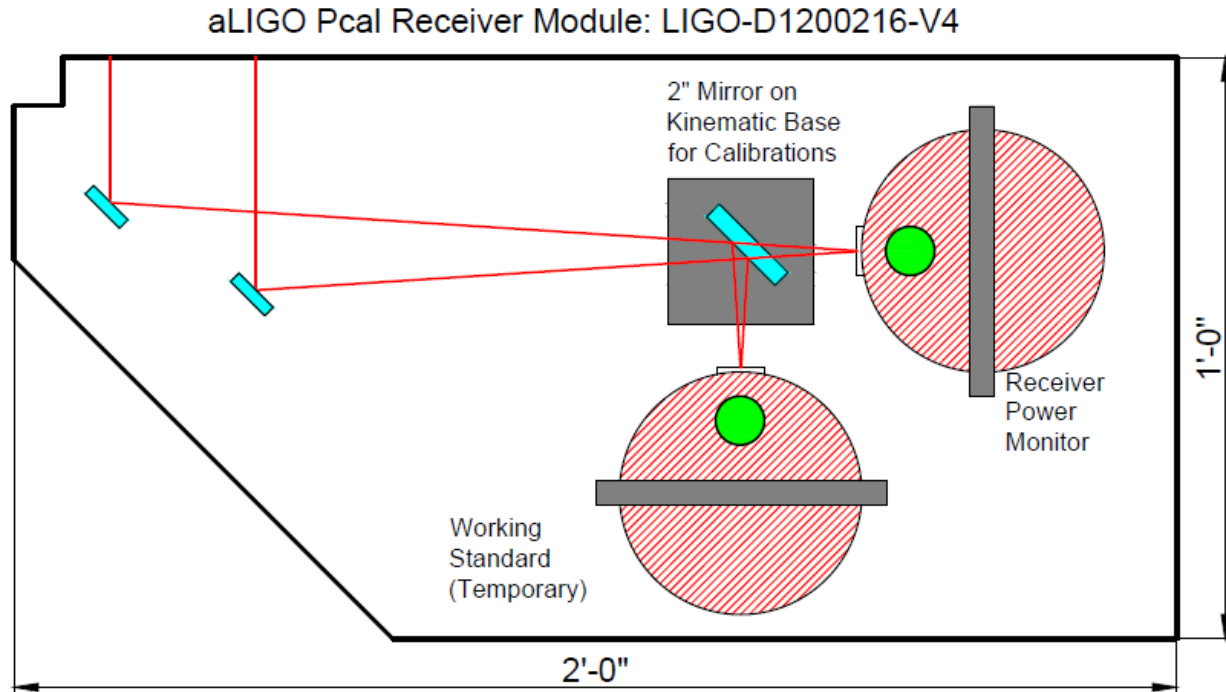

Figure 27 – Receiver Module Layout ([LIGO-D1200216](#)).

5.2 Calibration of the Photodetector

The receiver module's power monitor will be calibrated about as often as the transmitter module's power monitor. Comparison of the transmitter and receiver module power sensors will enable assessment and tracking of changes in the transmissivity of the optical path between the transmitter and receiver modules – the vacuum windows and the ETM HR surface.

This is to ensure that the read-back at the receiving point is stable and accurate. In addition, calibration staff may elect to use both photodetectors equal agents for the interferometer calibration.

Calibrating the receiver photodetector may be done by either the local Working Standard or by comparing the response of the transmitter read-back and the receiver read-back for a defined period.

5.3 Receiver Module Pylon

The Pcal receiver modules will incorporate 12" x 18" x 3/4" thick aluminum breadboards that will be mounted in an opening in the pylons for the Optical Lever receiver modules. The breadboards will have 1/4"-20 tapped holes on 1" centers. The Pcal receiver module will be covered on all sides with painted aluminum sheet metal housing that will be bolted to the Optical Lever receiver pylon. A viewport protector will be installed on the viewport window and a flexible bellows will connect the Pcal receiver module enclosure to the viewport protector.

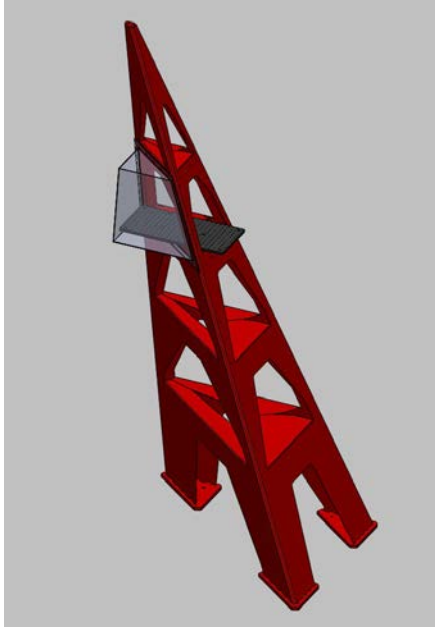

Figure 28 – Photon Calibrator receiver breadboard mounted inside of the Optical Lever receiver pylon with enclosure surrounding the module.

6 Absolute Laser Power Calibration

The absolute power calibration strategy described in Section 2.1 relies on a Gold Standard that is calibrated by NIST and Working Standards that are used to calibrate the Pcal power sensors located inside of the transmitter and receiver modules.

6.1 The Gold Standard Laser Power Sensor

The power sensor that is sent to NIST for absolute power calibration is referred to as the Gold Standard. NIST calibrates LIGO’s Gold Standard according to guidelines specified in NIST document [SP 250-75](#). LIGO donated a 1047nm laser to NIST for use in calibrating the eLIGO Gold Standard. This significantly reduces the cost to LIGO for the NIST’s calibration services. During eLIGO, NIST achieved a calibration precision of $\frac{2\sigma}{\mu} < 1\%$. The Gold Standard will be sent to NIST annually for calibration. The cost is approximately \$8000.00 per calibration.

Both the Gold Standard and the Working Standards use 4” diameter integrating spheres manufactured by Labsphere in North Sutton, NH (model [3P-040-LPM-SL](#)) with Spectralon surface coatings, 1” diameter entrance apertures, and ½” diameter detector apertures.

Receiver module packages sold by Labsphere are used. The photodetectors for these packages are manufactured by Electro-Optical Systems (model IGA-030-TE2-H), of Phoenixville, PA, and are mounted to the spheres. These receivers use hermetically-sealed InGaAs photodetectors mounted on thermo-electric coolers. We operate them at -10°C . These receivers are operated unbiased, in “photovoltaic” mode. Their photocurrents are converted to voltages by fast current amplifiers sold by Keithley Instruments of Cleveland, OH (model [428 PROG](#)). The outputs are read and digitized

by Keithley Model [2000](#) digital multi-meters. The Working Standard system, which is identical to the Gold Standard system, is shown in Figure 29.



Figure 29 – eLIGO Working Standard power sensor including the integrating sphere, photo-receiver module, fast current amplifier, digital multimeter, and power supply/thermo-electric cooler controller.

Using the Gold and Working standards since 2007, we have found the receiver module manufactured (packaged) by Labsphere to be less stable and less reliable than photo-receiver modules manufactured and sold by Electro-Optical Systems (EOS). These modules use the same detector package as the Labsphere receivers, but with better-engineered heat sinking and an integrated transimpedance pre-amplifier that uses a single operational amplifier. During eLIGO, the Pcal systems at both LHO and LLO used internal power sensors that incorporated these EOS receivers. For aLIGO, we plan to switch to the EOS receiver modules on both the Gold and Working standards. We will likely also operate the receivers at room temperature, reducing the complexity by eliminating the thermoelectric cooler temperature stabilization control loop and thus improving reliability, as we have had several failures of the power supplies and temperature stabilization controllers. InGaAs is sufficiently insensitive to temperature variations at this wavelength and the variations in ambient and sphere temperatures are small enough that operating at room temperature should not introduce significant changes in the absolute calibration.

6.2 The Working Standard Laser Power Sensors

Calibrating the Pcal internal power sensors (in both the transmission and receiver modules) for absolute power calibration requires travel to the end stations with a NIST-traceable standard, at both LHO and LLO. Rather than taking the Gold Standard to the end stations, we establish derivative standards called *Working Standards*. During eLIGO, there was only one Working Standard and we shipped it periodically to LLO to calibrate the L1 interferometer. During aLIGO, there will be two Working Standards, both of which will be calibrated periodically to the Gold Standard. This will allow us to increase the frequency of calibrations of the power sensors at the

end stations at LLO and reduce the number of times that Working Standards need to be shipped between sites, saving about \$1,000 in round trip shipping costs.

7 Calibration Procedures

7.1 Calibration of the Working Standard

The Gold Standard calibration (from NIST) is transferred to the Working Standard using the optical configuration shown schematically in Figure 30.

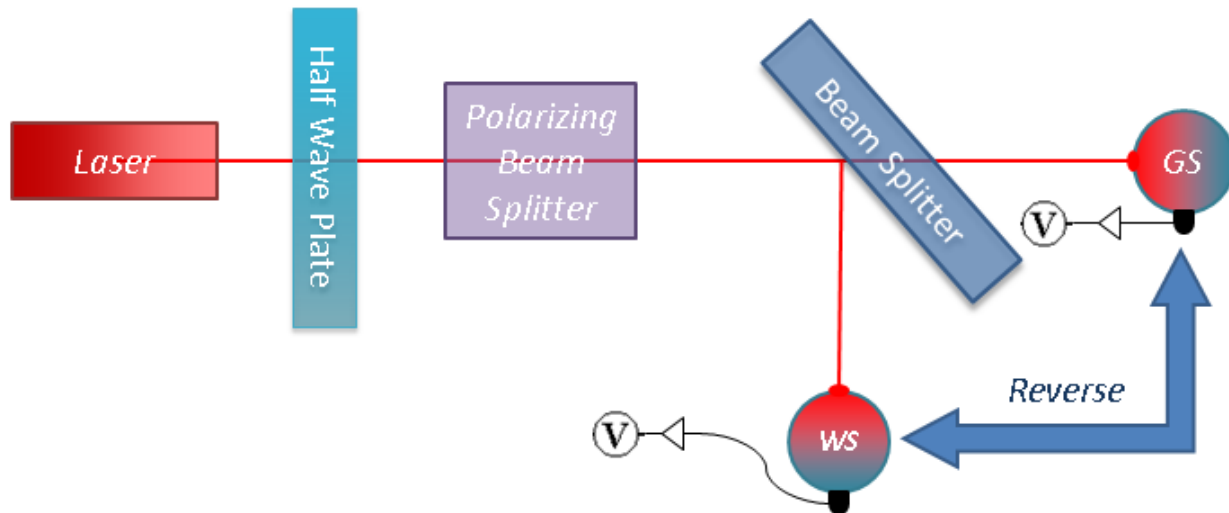

Figure 30 – Working Standard-Gold Standard calibration setup

A photograph of the actual setup, located in one of the optical laboratories at LIGO Hanford Observatory, is shown in Figure 31.

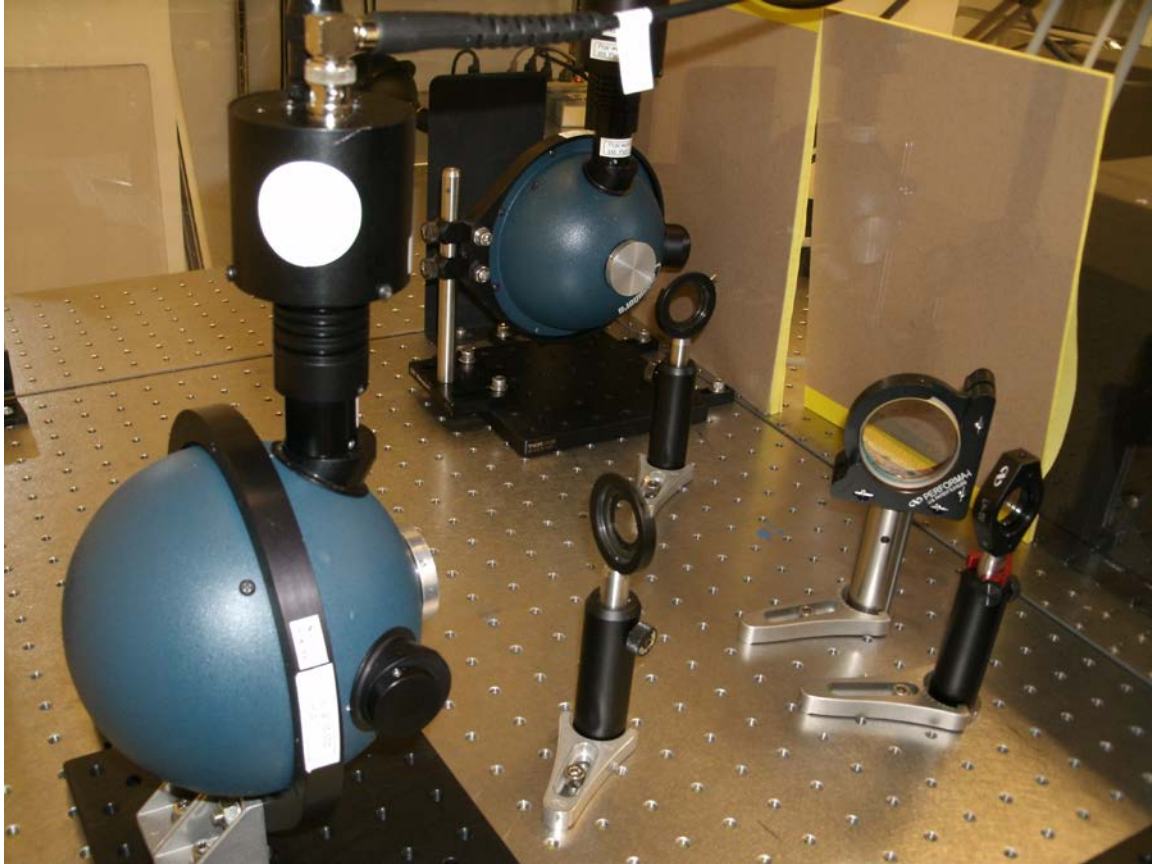

Figure 31 - Photo of optical setup for transferring the NIST calibration from the Gold Standard (left, foreground) to the Working Standard (right, background)

The laser used in this setup is identical to the lasers that are used in the Pcal transmitter modules. The beamsplitter is a 2" diameter, fused silica, 3° wedge with a nominal 50% reflectivity. The detailed procedure for transferring the calibration can be found in [LIGO-T1100315](#). In summary, each of the two sensors measures light at one of two ports of the beamsplitter (transmission or reflection), data are recorded simultaneously, and then the locations of the power sensors are swapped (reversed) and the measurements are repeated.

The relative calibration of the Working Standard is calculated as follows:

$$\frac{\text{Working Standard Responsivity}}{\text{Gold Standard Responsivity}} = \sqrt{\frac{WS_{reflR} WS_{transT}}{GS_{transT} GS_{reflR}}} = \sqrt{\frac{WS_{refl} WS_{trans}}{GS_{trans} GS_{refl}}} \quad (7)$$

where the subscripts *refl* and *trans* indicate the location of the sensor for a particular measurement and *T* and *R* are the power transmissivity and reflectivity of the beamsplitter, respectively. *T* and *R* do not need to be measured independently they appear in both the numerator and denominator of Equation (7) and therefore cancel.

7.2 Calibration of Transmitter and Receiver Module Power Sensors

7.2.1 Frequency of Calibration

Each power sensor will be calibrated at least once every 2 months using the local Working Standard.

The calibration procedure that was used during eLIGO is detailed in the Photon Calibrator Calibration Procedure (<http://www.ligo-wa.caltech.edu/~michael.sakosky/PCALcal.html>). This procedure compares the response of the Photon Calibrator internal photodetector with the response of the Working Standard at two different DC voltages injected into the excitation channel. The calibration formula, which is applied to each of the two Pcal output beams, is as follows:

$$\frac{\Delta \text{Volts}_{WS}}{\Delta \text{Counts}_{PM}} (DC) = \frac{\text{Volts}_{WS}(1 \text{ Volt}) - \text{Volts}_{WS}(0 \text{ Volts})}{\text{Counts}_{PM}(1 \text{ Volt}) - \text{Counts}_{PM}(0 \text{ Volts})} \quad (8)$$

Equation (8) indicates how the reading from the transmitter/receiver internal photodetectors (“Counts_{PM}”) and the Working Standard (“Volts_{WS}”) combine to form a “Box Calibration,” as it was called during eLIGO. This result can be combined with the Gold Standard and Working Standard Calibrations to give the Pcal transmitter module output power in watts:

$$\Delta p_{Watts} = \Delta \text{Counts}_{PM} \frac{\Delta \text{Volts}_{WS}}{\Delta \text{Counts}_{PM}} \frac{\text{Volts}_{GS}}{\text{Volts}_{WS}} \frac{\text{Watts}_{NIST}}{\text{Volts}_{GS}} \quad (9)$$

The power sensor calibration in Equation (9) together with the transmissivity of the Pcal input window and reflectivity of the ETM coating is used to convert the internal power sensor signal to p_0 , the amplitude of the modulated laser power Equation (1).

8 Failure Modes and Hazards

8.1 Internal Photodetector Fails

This occurred during S6 in the Pcal transmitter module for ETMX on the L1 interferometer. The trend of the voice coil actuator calibration revealed the step in the calculated actuation coefficient when the receiver failed. For aLIGO, there will be two power sensors per Pcal system, one in the transmitter module and one in the receiver module. Continuous monitoring of the ratio of the signals from the two sensors will reveal a failure if one should occur. Calibration using the working standard will reveal which sensor changed its responsivity. Continuity of the interferometer calibration can be maintained by referring to the sensor that did not suffer the failure.

8.2 Gold Standard or Working Standard Fails

If this were to occur, one of the other standards could take the place of the failed standard and the continuity of the NIST calibration could be maintained by referring to the standards that did not suffer the failure. Note that for aLIGO we plan to have three calibration standards, the Gold Standard and one Working Standard at each observatory. Periodic cross-calibration of the standards and yearly calibration of the Gold Standard at NIST ensures the ability to identify a calibration standard failure.

8.3 Laser Fails

If a laser or entire Photon Calibrator system would fail, the interferometer calibration would still be maintained from the Photon Calibrator of the opposite arm of the interferometer. If the finesses of each arm are approximately equal, as they were during eLIGO, the interferometer cannot differentiate between actuation from either arm, so this failure would not be a critical concern. The only concern of this failure would be less power available for calibration, thus lowering the SNR of calibration lines and precision of the calibration.

8.4 Misalignment of Receiver-Side Periscope

If the receiver-side in-vacuum periscope would be misaligned and the beam no longer cleanly passes out the receiver viewport window, then that receiver system would no longer be operable until the next in-vacuum entry. In this case, we would rely on the transmitter side power sensor and other arm's Pcal system for the calibration. Additionally, because the wavelength of the Pcal laser is at least 0.3 nm away from the wavelength of the main interferometer laser, Pcal stray light introducing noise into the interferometer signals should not be an issue.

8.5 Misalignment of Transmitter-Side Periscope

If the transmitter-side periscope were to drift so that the beam spot would drift from its optimal position on the ETM by several millimeters or clip on another in-vacuum component, that Pcal system would be compromised. However, continuous monitoring of the beam positions on the ETM surface, each time the interferometer loses lock, for instance, would reveal changes in the input beam alignment. The alignment could be corrected by the steering mirrors located outside the vacuum envelope.

8.6 Damage to Viewport Glass

Viewport protectors will preclude physical access to the viewport glass during maintenance operations, as outlined in [LIGO-T1000023](#). During normal operation, the viewport glass will be exposed to the interior of the transmitter and receiver modules which will be fully enclosed and the enclosure covers will be interlocked such that an alarm will sound if they are removed without authorized access to the Pcal modules. The only movable component inside the Pcal modules is the mechanical shutter inside the transmitter module and it will be located far from the viewport glass.

9 Required Drawings and Documents

9.1 Hardware Drawings/Bill of Materials

9.1.1 Transmitter Pylon (same for all ETMs, 6 required)

1. Pcal Transmitter Pylon ([LIGO-D1000625](#)) (1 required)

9.1.2 Transmitter Module (same for all ETMs, 6 required)

1. Transmitter Module Layout ([LIGO-D1102196](#))

2. Transmitter Module Breadboard ([Thorlabs UltraLight PBG12110 3'x2.5'x2.2"](#)) - [COTS with a few additional clearance holes.]
3. Transmitter Module Enclosure - [Folded sheet metal, [similar design to eLIGO.](#)]
4. Transmitter Module Breadboard Mounting Adapter (2 required) - ([LIGO-D1200450](#))
5. Transmitter Module Laser Shutter (1 required) - ([RT Technologies: LS 10-12](#))

9.1.3 Receiver Module (same for all ETMs, 6 required)

1. Receiver Module Layout ([LIGO-D1200216](#))
2. Receiver Module Breadboard ([Thorlabs MB1224](#)) - [COTS]
3. Receiver Module Enclosure - [Folded sheet metal, [similar design to eLIGO.](#)]
4. Receiver Module Breadboard 1.5" Spacers (3 required)

9.1.4 In-Vacuum Pcal-Video Cam Periscope Assembly (same for each ETM, except left-right symmetry)

9.1.4.1 H1/L1 (4 required)

Main Assembly ([LIGO-D1200174](#))

Sub-assembly: Launch Window-Side Periscope ([LIGO-D1200170](#))

Sub-assembly: Receive ETM-Side Periscope ([LIGO-D1200172](#))

Sub-assembly: Receive Window-Side Periscope ([LIGO-D1200171](#))

Sub-assembly: Compression Ring ([LIGO-D1200169](#))

Sub-assembly: 2" Mirror and Mount Assembly ([LIGO-D1102439](#))

1. Compression Ring Half, H1 Launch Side ([LIGO-D1102353](#)) (1 required)
2. Compression Ring Half, H1 Receive Side ([LIGO-D1102354](#)) (1 required)
3. Ring Plate Mounting Adapter ([LIGO-D1102355](#)) (4 required)
4. Receive, Window-Side, Ring Mounted, Periscope Plate ([LIGO-D1102356](#)) (1 required)
5. Launch, Window-Side, Ring Mounted, Periscope Plate ([LIGO-D1102357](#)) (1 required)
6. Launch, ETM-Side, Ring Mounted, Periscope Plate ([LIGO-D1102358](#)) (1 required)
7. Receive, ETM-Side, Ring Mounted, Periscope Plate ([LIGO-D1102359](#)) (1 required)
8. 2" Mirror Mount 45° Round ([LIGO-D1101560](#)) (4 required)
9. 2" Mirror Mount 45° Round Base ([LIGO-D1102360](#)) (4 required)
10. Pcal Tube Standoff ([LIGO-D1200175](#)) (9? required)
11. 2" Siskiyou Mount with Hex Drive Option ([Siskiyou IXM200.C2-RH,-LH](#)) (4 required)
12. Precision Photonics 2" Diameter x 3/8" Thickness, HR at 45 Deg Incidence Mirror (8 required)

9.1.4.2 H2 (2 required)

Main Assembly ([LIGO-1200179](#))

Sub-assembly: Compression Ring ([LIGO-D1200169](#))

Sub-assembly: Periscope Bridge ([LIGO-D1200180](#))

Sub-assembly: 2" Mirror and Mount Assembly ([LIGO-D1102439](#))

1. Compression Ring Half, H2 Launch Side ([LIGO-D1102362](#)) (1 required)
2. Compression Ring Half, H2 Receive Side ([LIGO-D1102363](#)) (1 required)
3. Ring Plate Mounting Adapter ([LIGO-D1102355](#)) (2 required)
4. Port Main Bridge Plate Structure ([LIGO-D1101598](#)) (1 required)
5. 2" Mirror Mount 45° Round ([LIGO-D1101560](#)) (6 required)
6. 2" Mirror Mount 45° Round Base ([LIGO-D1102360](#)) (6 required)
7. 2" Siskiyou Mount with Hex Drive Option ([Siskiyou IXM200.C2-RH,-LH](#)) (4 required)
8. Precision Photonics 2" Diameter x 3/8" Thickness, HR at 45 Deg Incidence Mirror (10 required)

9.1.5 ETM Camera In-Vacuum Periscope Hardware [Mike Smith, ISC] (same for each ETM, except left-right symmetry)**9.1.5.1 H1/L1 (4 required)**

Main Assembly: Pcal-Cameras Assembly ([LIGO-D1200174](#))

Sub-assembly: Top Mirror Mounting Plate and Mounted Mirror Assembly ([LIGO-1200195](#))

Sub-assembly: Bottom Mirror Mounting Plate and Mounted Mirror Assembly ([LIGO-1200193](#))

1. ETM Video Camera Mirror Mount ([LIGO-D1200173](#)) (2 required)
2. Video Camera 6" Mirror Mount ([LIGO-D1200176](#)) (4 required)
3. Mirror Mount Base (4 required)
4. Ring Plate Mounting Adapter ([LIGO-D1102355](#)) (2 required)
5. 6" Diameter or 4" x 6" Rectangular HR Mirror (4 required)

9.1.5.2 H2 (2 required)

Main Assembly: H2, Pcal-Cameras Assembly ([LIGO-1200179](#))

Sub-assembly: Bridge Plate Camera Mirror Assembly ([LIGO-1200180](#))

1. ETM Video Camera Mirror Mount ([LIGO-D1200173](#)) (2 required)
2. Video Camera 6" Mirror Mount ([LIGO-D1200176](#)) (4 required)
3. Mirror Mount Base (4 required)
4. Ring Plate Mounting Adapter ([LIGO-D1102355](#)) (2 required)
5. 6" Diameter or 4" x 6" Rectangular HR Mirror (4 required)