

D1100208_ALIGO_AOS_Output Faraday Isolator Spacer (HAM5-L1), PART PDM REV: X-009, DRAWING PDM REV: X-011

- NOTES CONTINUED:**
- ⑤ SCRIBE, ENGRAVE, OR MECHANICAL STAMP (NO INK OR DYES) DRAWING PART NUMBER, REVISION, USED, CHAMBER ON NOTED SURFACE OF PART FOLLOWED ON THE LINE WITH A THREE DIGIT SERIAL NUMBER. SERIAL NUMBERS START AT 001 FOR THE FIRST ARTICLE AND PROCEED CONSECUTIVELY. USE MINIMUM 0.12" HIGH CHARACTERS, UNLESS THE SIZE OF THE PART DICTATES SMALLER CHARACTERS. A VIBRATORY TOOL MAY BE USED. EXAMPLE: DXXXXXX-VY, TYPE-XX, S/N XXX, SR2, HAM5-L1.
 - ⑥ APPROXIMATE WEIGHT = 37.72 LB.
 - 7. ALL PARTS SHALL BE MANUFACTURED IN ACCORDANCE WITH LIGO SPECIFICATION E0900364.
 - 8. ALL MATERIAL IS TO BE VIRGIN MATERIAL (i.e. NO WELD REPAIRS, PLUGS OR RECYCLED MATERIAL). NO REPAIRS SHALL BE MADE UNLESS APPROVED IN ADVANCE, AND IN WRITING, BY LIGO LABORATORY. REFER TO LIGO-E0900364.
 - 9. SURFACE FINISH TO BE AS-PROCESSED FROM MILL/SUPPLIER, FREE FROM SCRATCHES OR GOUGES.

REV.	DATE	DCN #	DRAWING TREE #
v2	25 APR 2011	-	-
v3	15 SEP 2011	-	-
v4	09 AUG 2012	-	-

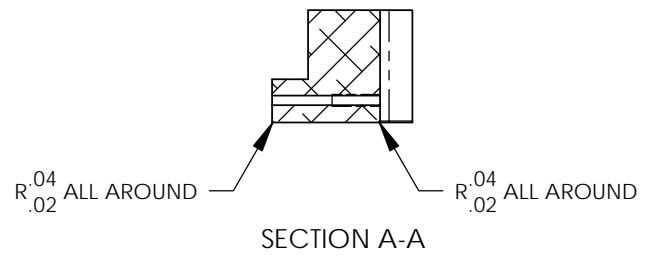
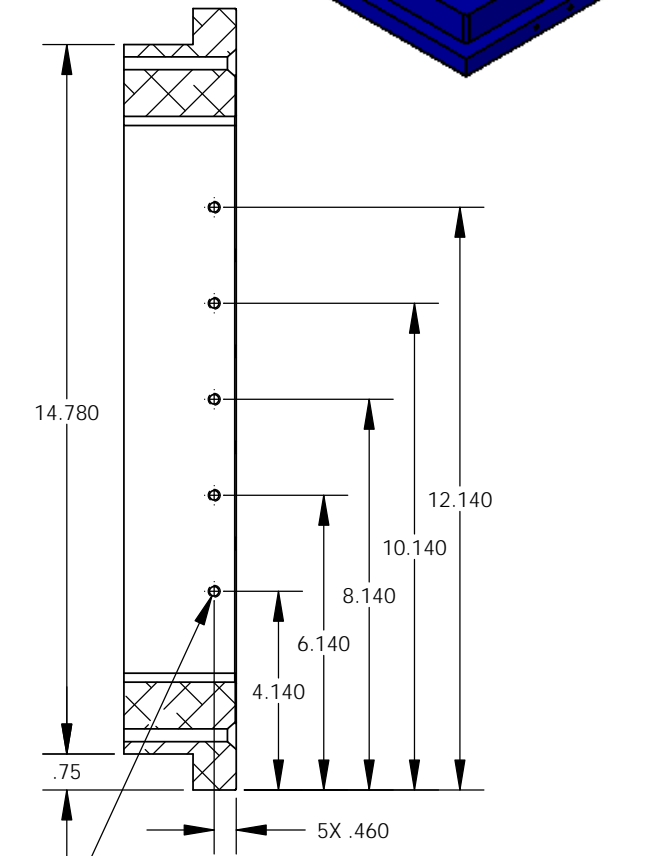
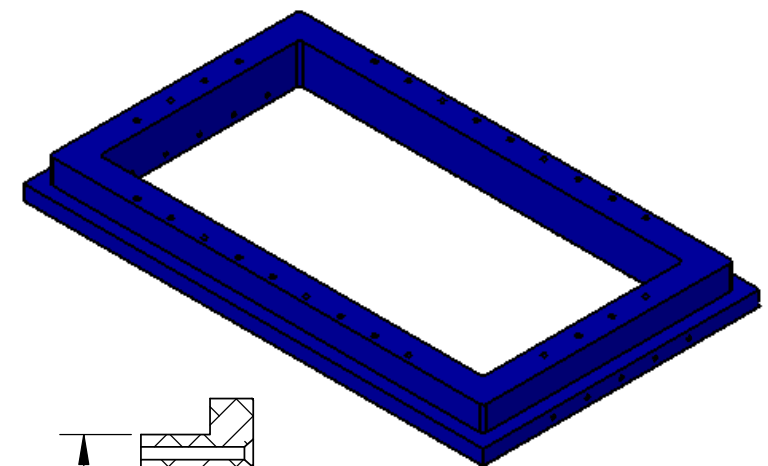
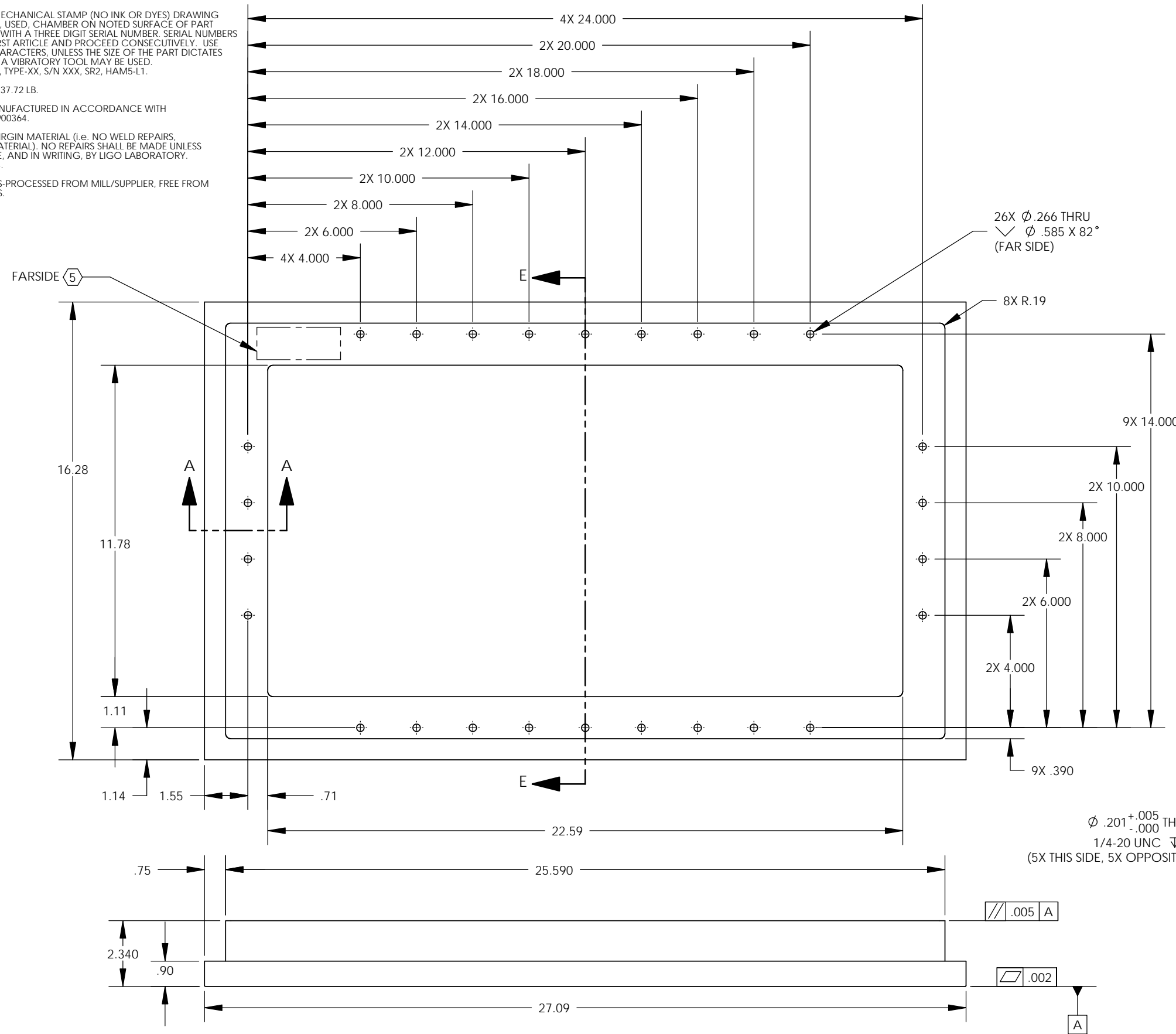

NOTES AND TOLERANCES: (UNLESS OTHERWISE SPECIFIED)	
1. INTERPRET DRAWING PER ASME Y14.5-1994. 2. REMOVE ALL SHARP EDGES, .005-.015, FOR MACHINED PARTS. ROUND ALL EDGES APPROXIMATELY R.02 FOR SHEET METAL PARTS. 3. DO NOT SCALE FROM DRAWING. 4. ALL MACHINING FLUIDS MUST BE FULLY SYNTHETIC, FULLY WATER SOLUBLE AND FREE OF SULFUR, SILICONE, AND CHLORINE.	
DIMENSIONS ARE IN TOLERANCES: .XX ± .01 .XXX ± .005 ANGULAR ± .5°	MATERIAL: 6061-T6 Al FINISH: 63 μinch

LIGO CALIFORNIA INSTITUTE OF TECHNOLOGY MASSACHUSETTS INSTITUTE OF TECHNOLOGY		PART NAME Output Faraday Isolator Spacer (HAM5-L1)	
SYSTEM ADVANCED LIGO	SUB-SYSTEM AOS	DESIGNER M. RUIZ	DATE 04 FEB 2011
DRAFTER ED CHAVEZ	DATE 08 MAY 2012	SIZE B	DWG. NO. D1100208
CHECKER APPROVAL	REVISION v4	SCALE: 1:4	PROJECTION:
		SHEET 1 OF 2	

8 7 6 5 4 3 2 1

D C B A

D C B A

8 7 6 5 4 3 2 1

D1100208_ALIGO_AOS_Output Faraday Isolator Spacer (HAM5-L1), PART PDM REV: X-009, DRAWING PDM REV: X-011

8 7 6 5 4 3 2 1

D
C
B
A

D
C
B
A

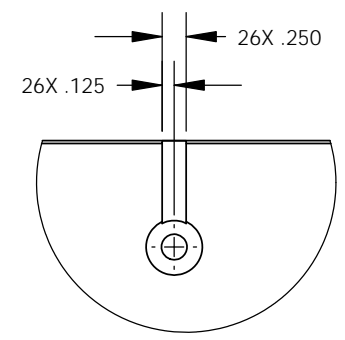

DETAIL B
SCALE 1 : 2

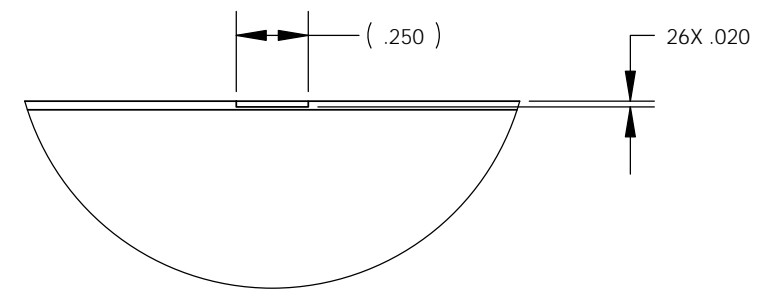
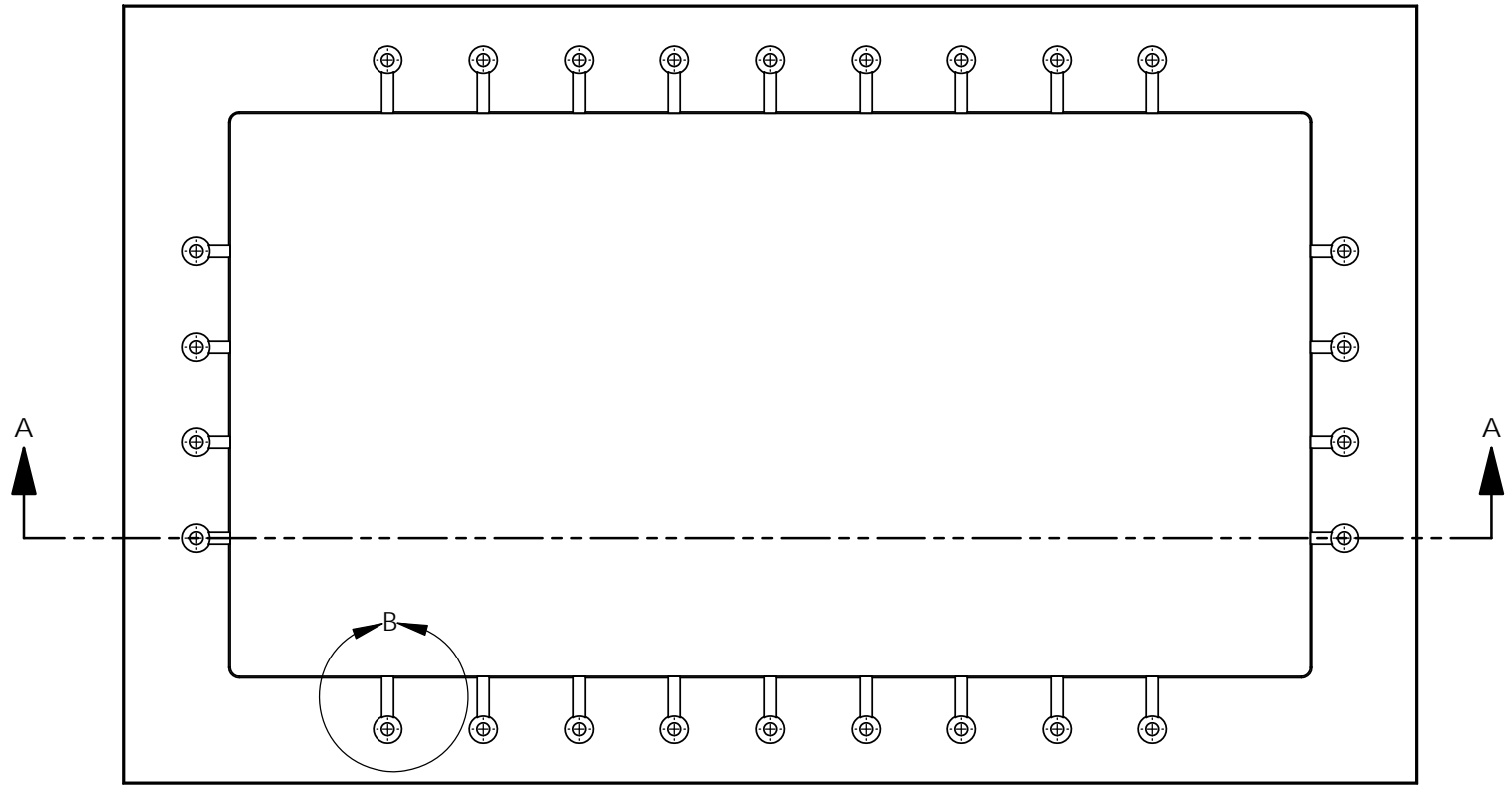

DETAIL C
SCALE 1.5 : 1

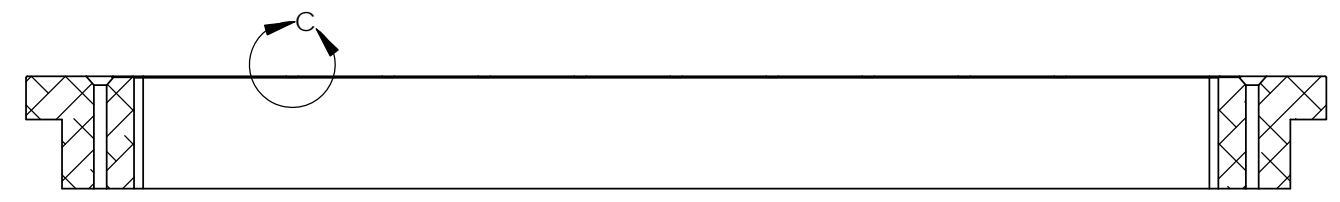

SECTION A-A

 CALIFORNIA INSTITUTE OF TECHNOLOGY MASSACHUSETTS INSTITUTE OF TECHNOLOGY		
SIZE B	DWG. NO. D1100208	REV. v4
SCALE: 1:4	PROJECTION: 	SHEET 2 OF 2

8 7 6 5 4 3 2 1