

Progress of the ETF Active Isolation and Alignment Prototype

Wensheng Hua, Brian Lantz, Corwin
Hardham, **Colin Campbell, Dan DeBra**, Joe Giaime,
Joe **van Niekerk**, Norna Robertson

ETF In The Tank



LIGO-G040163-00-Z

Hierarchical Structure of the Control System: Damper

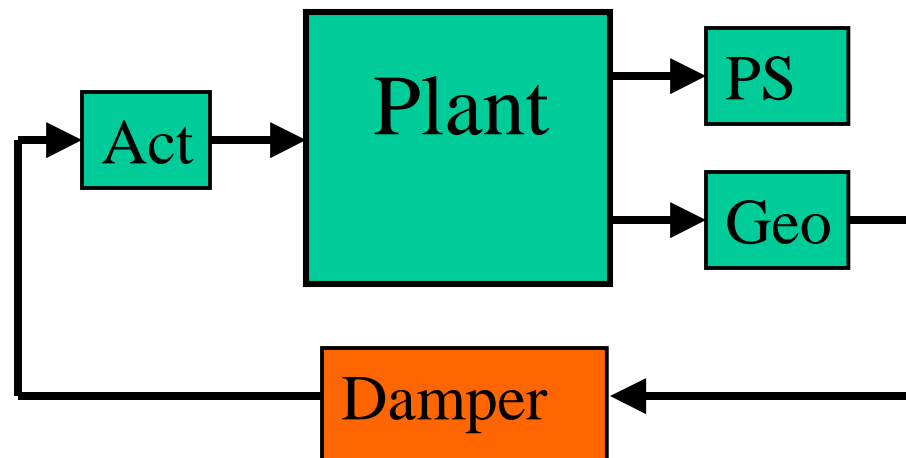

ETF Stage1 Hori Transfer Function: From Actuator to Position Sensor

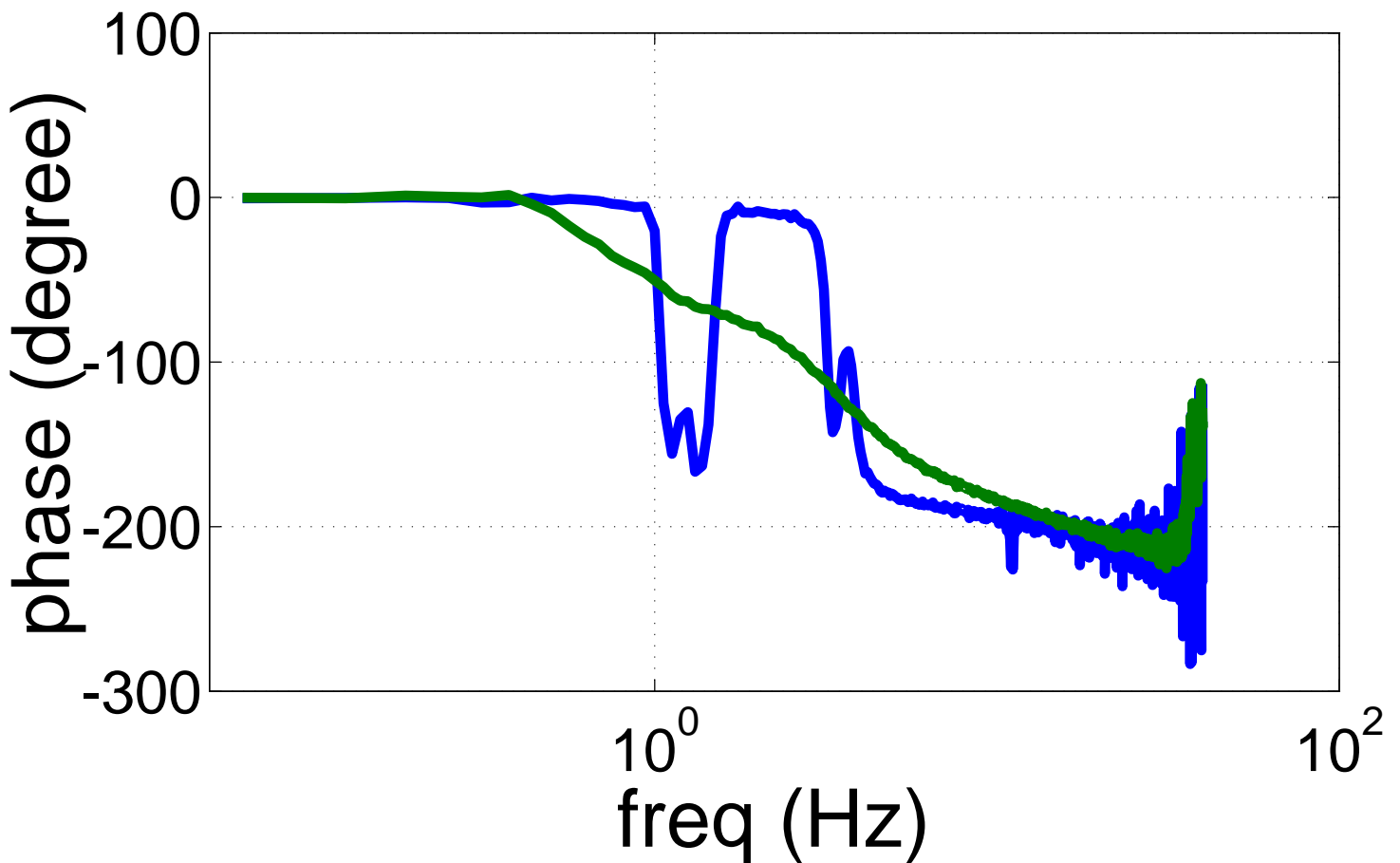
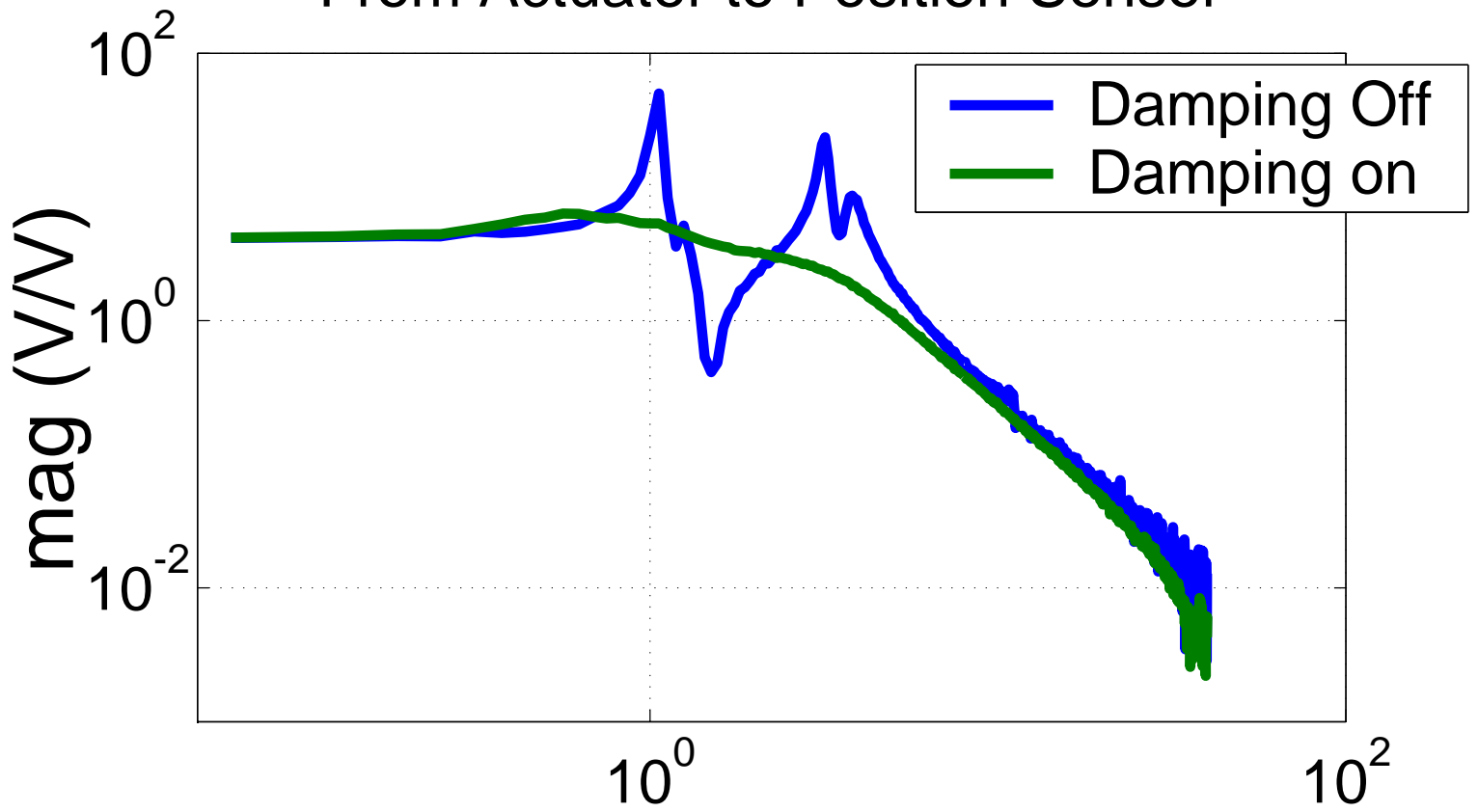

Hierarchical Structure of the Control System: Tilt Controller

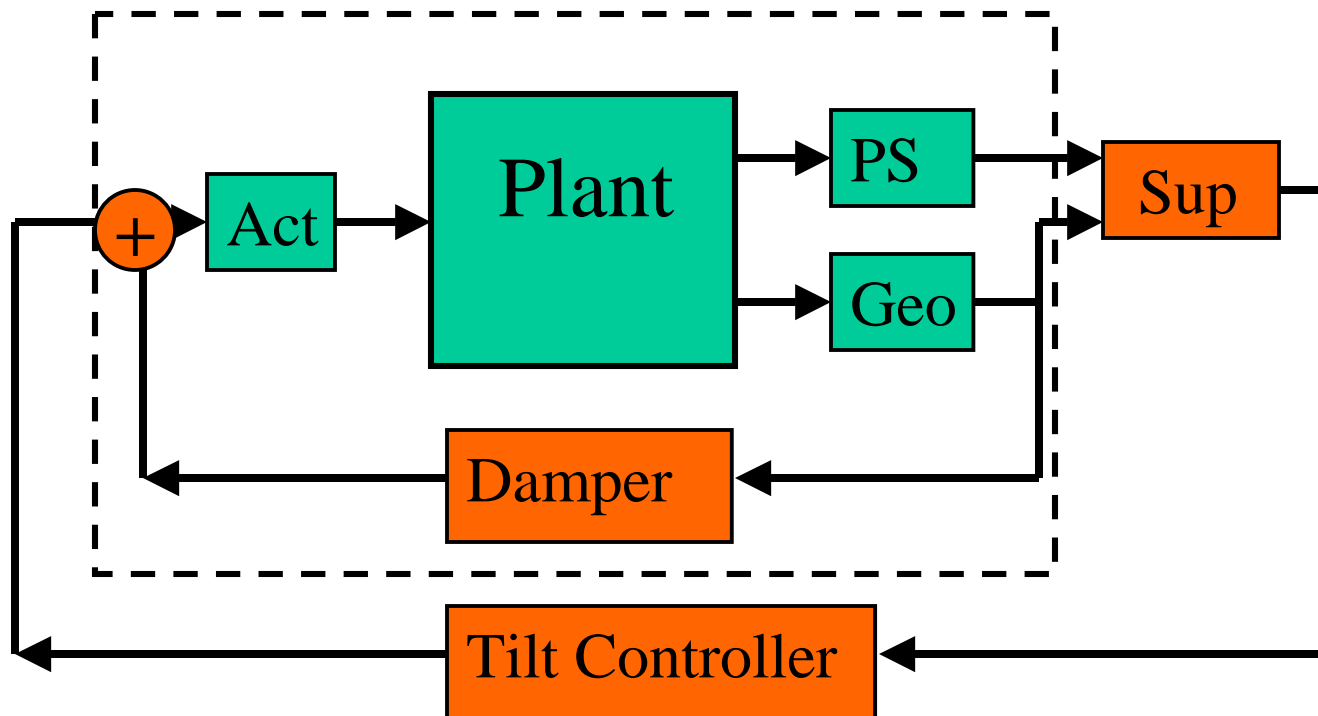

Hierarchical Structure of the Control System: Other Controllers

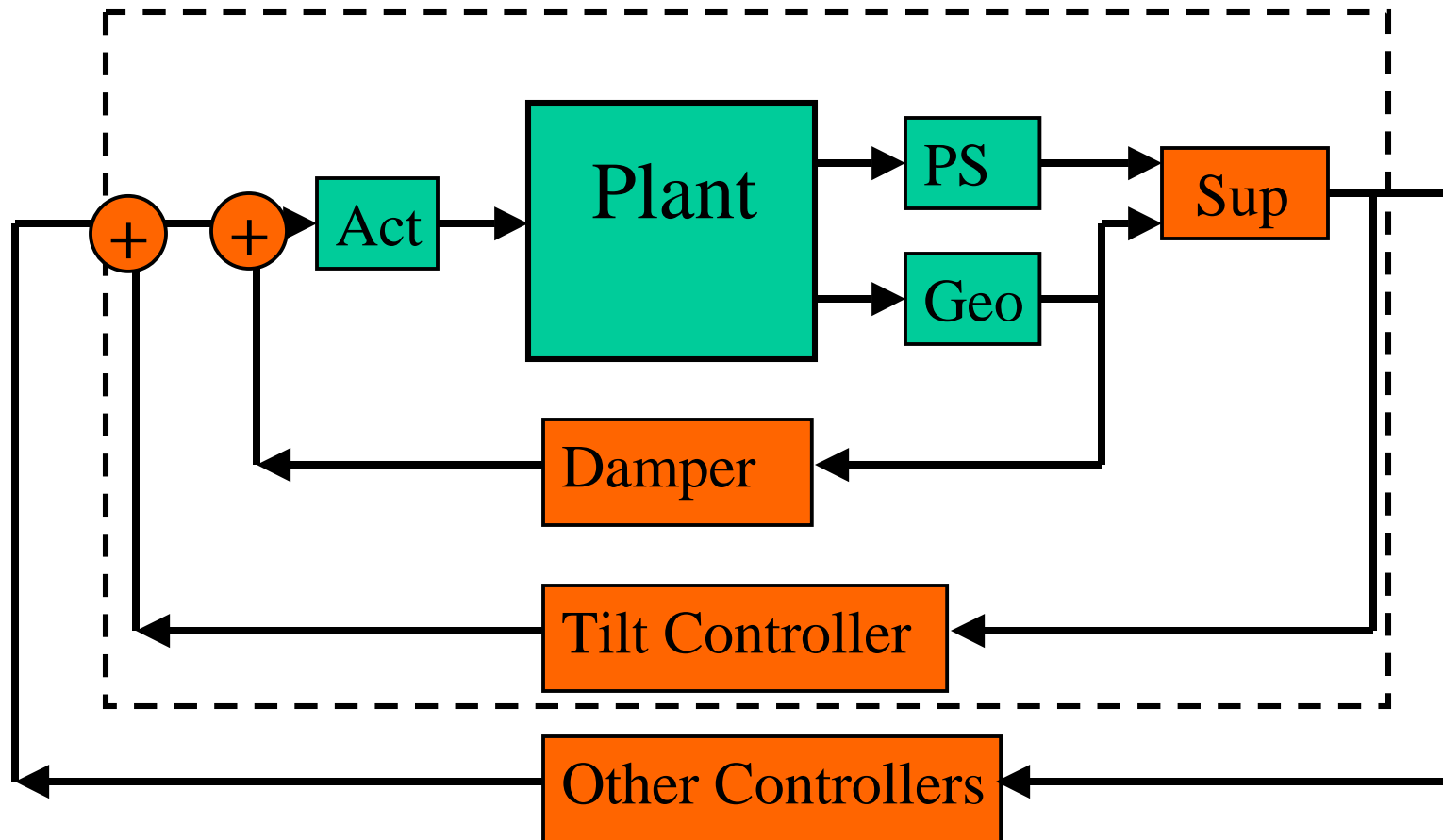

Stage2 Control Z

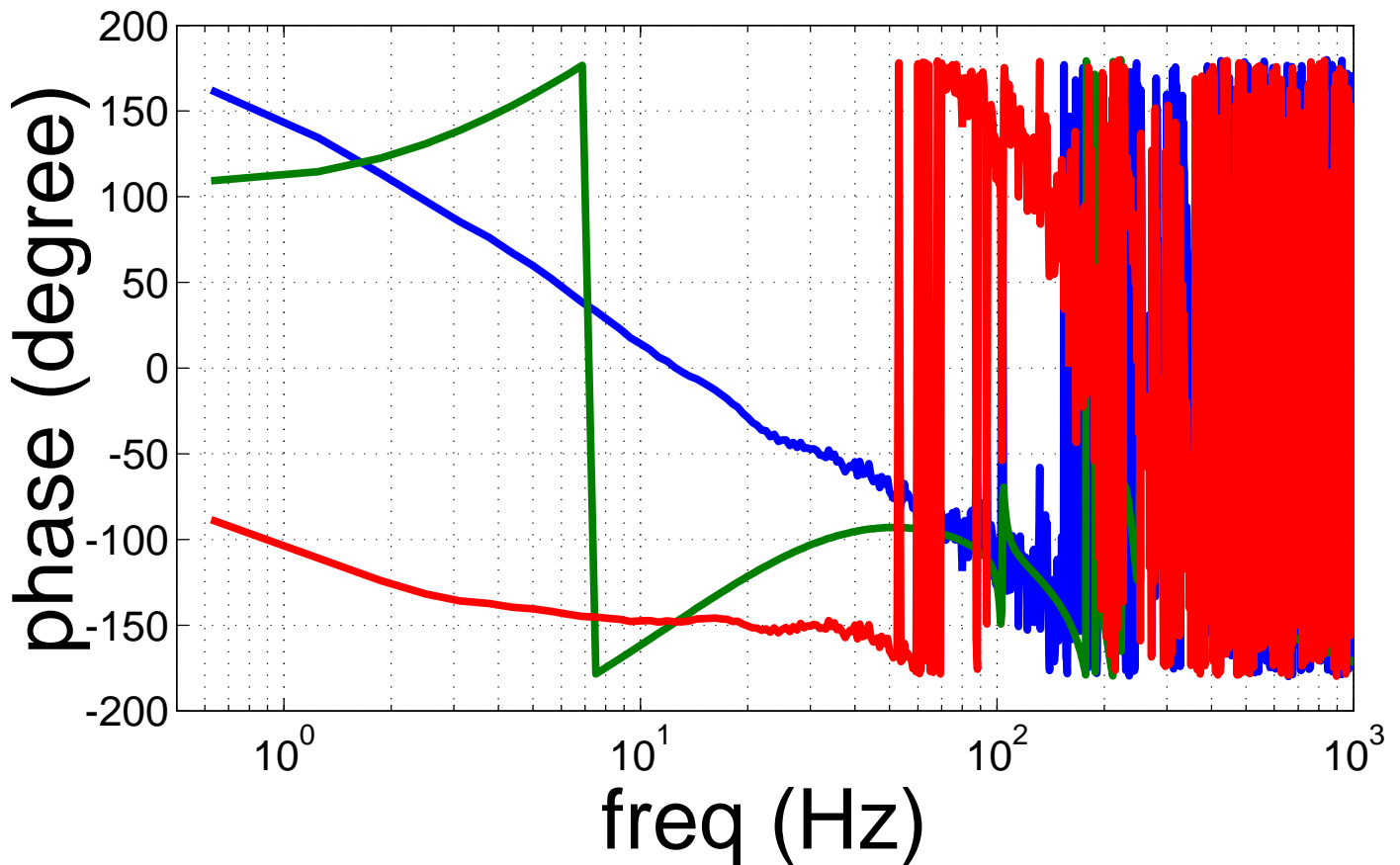
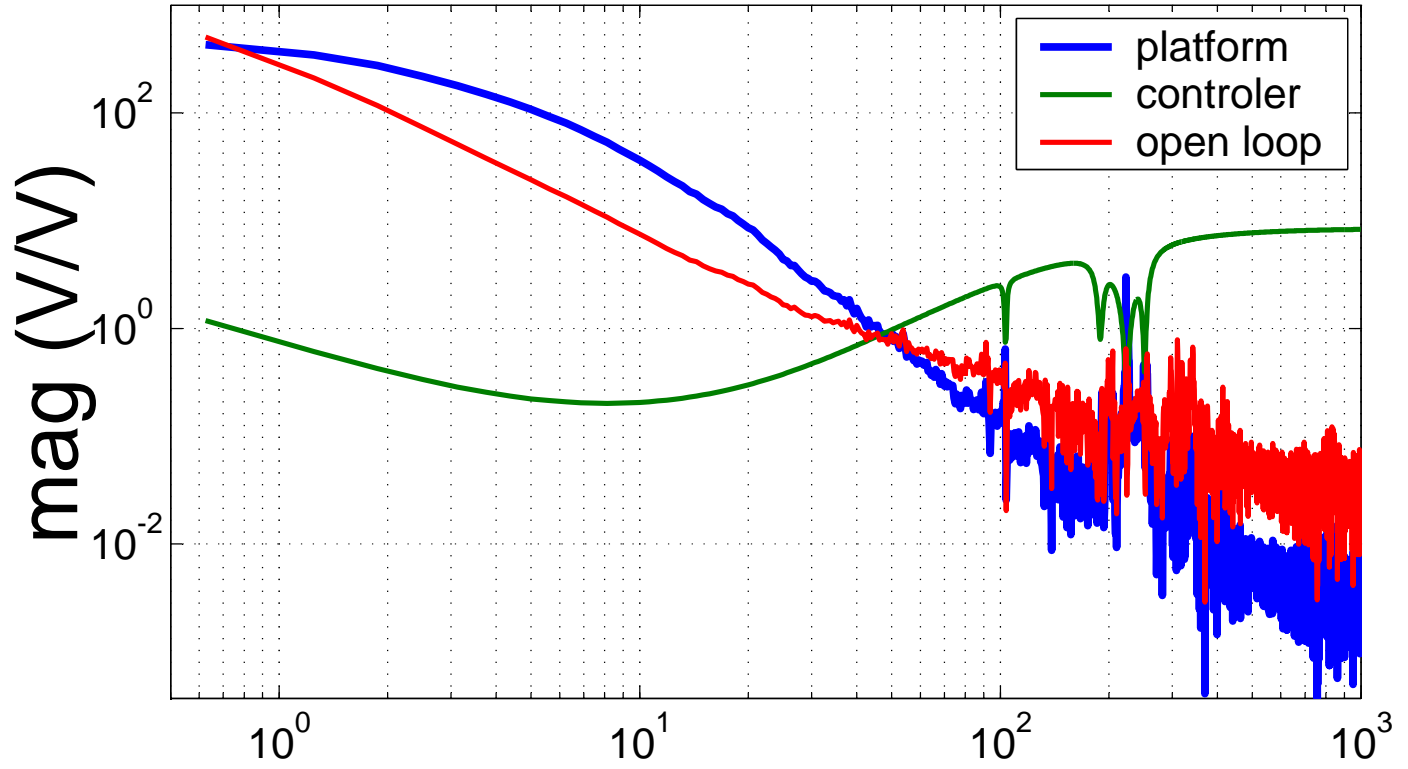

Hierarchical Structure of the Control System: Booster

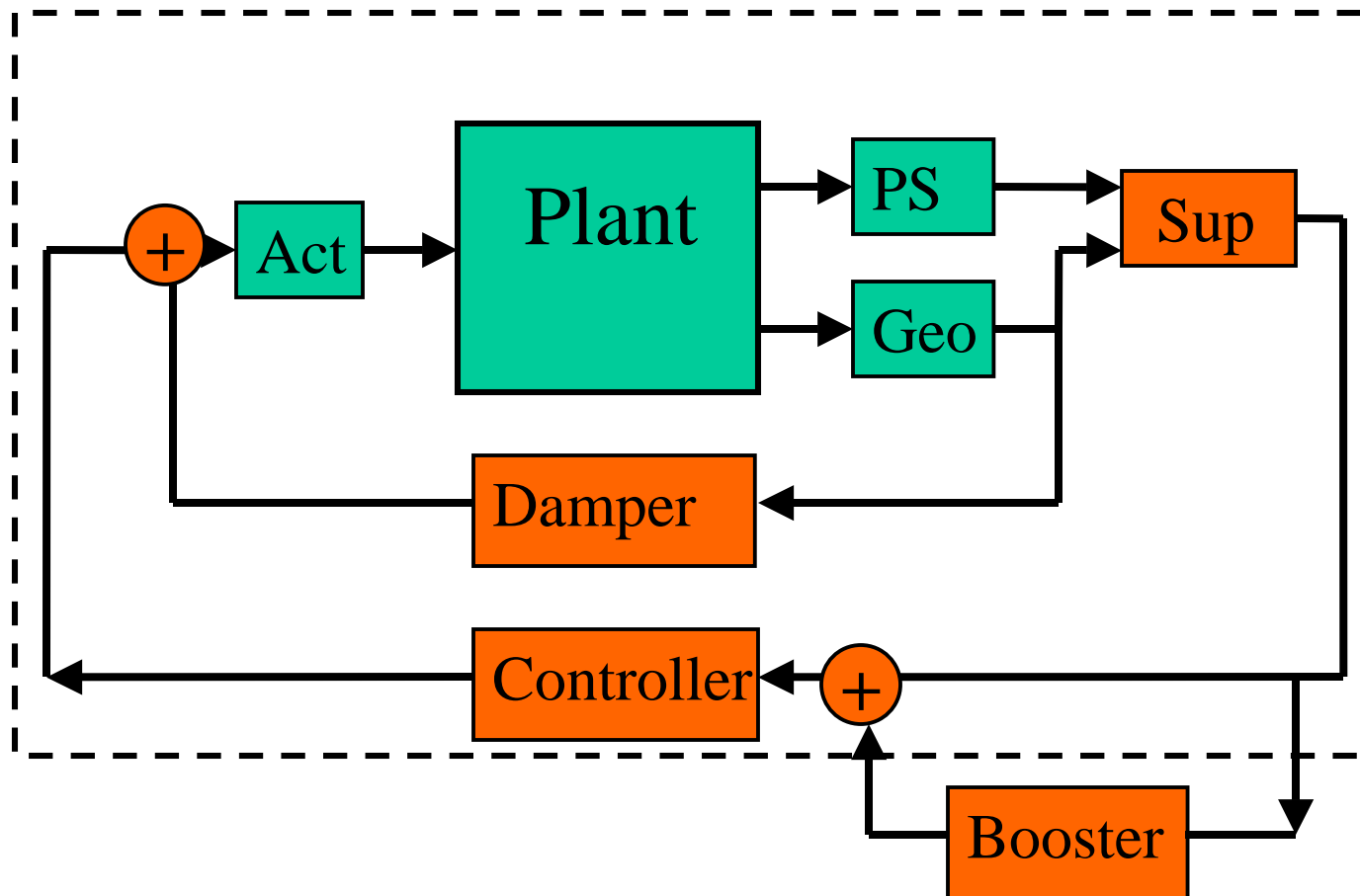

Booster Control

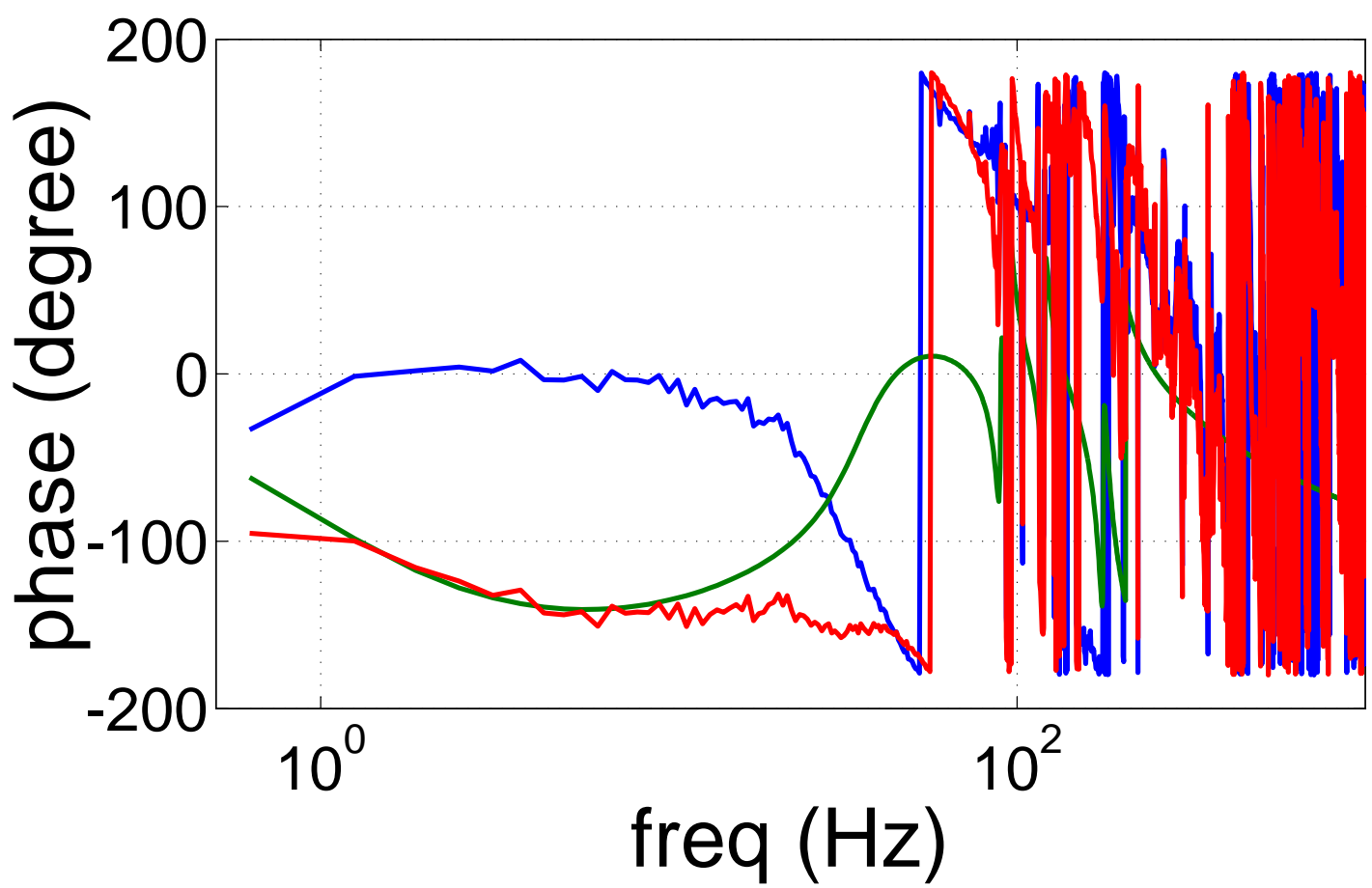
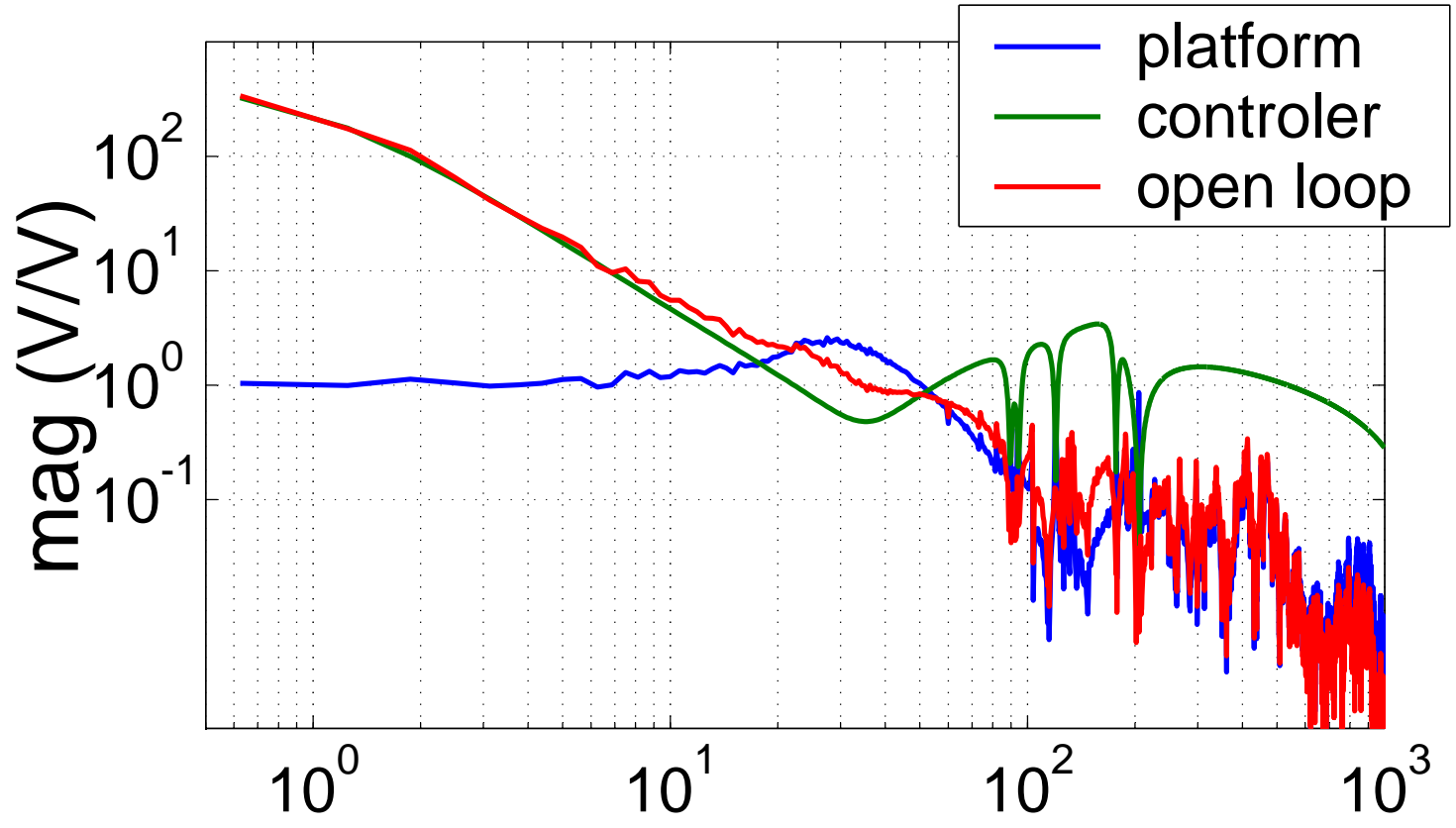

ETF CONTROL

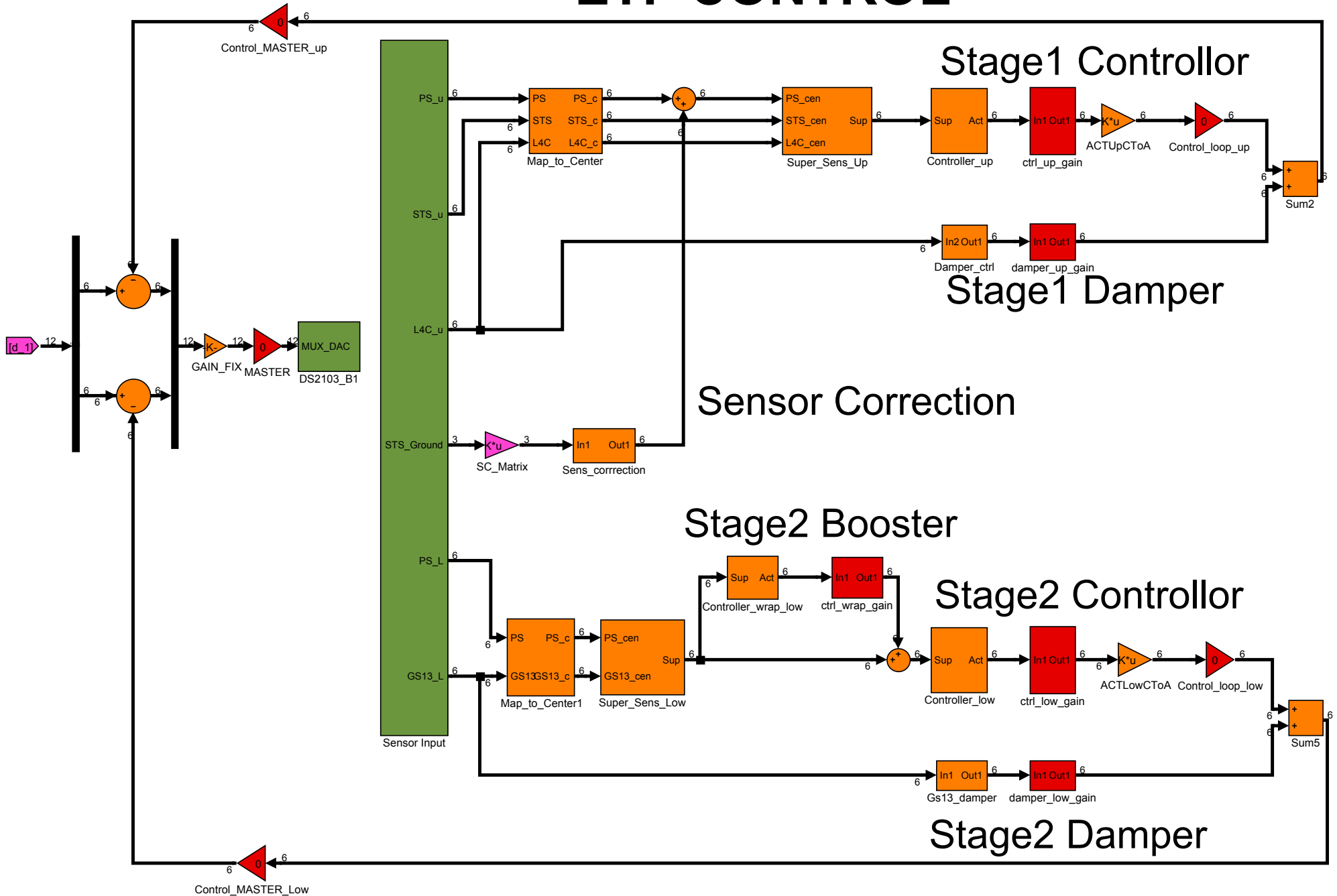

ETF Performance: X

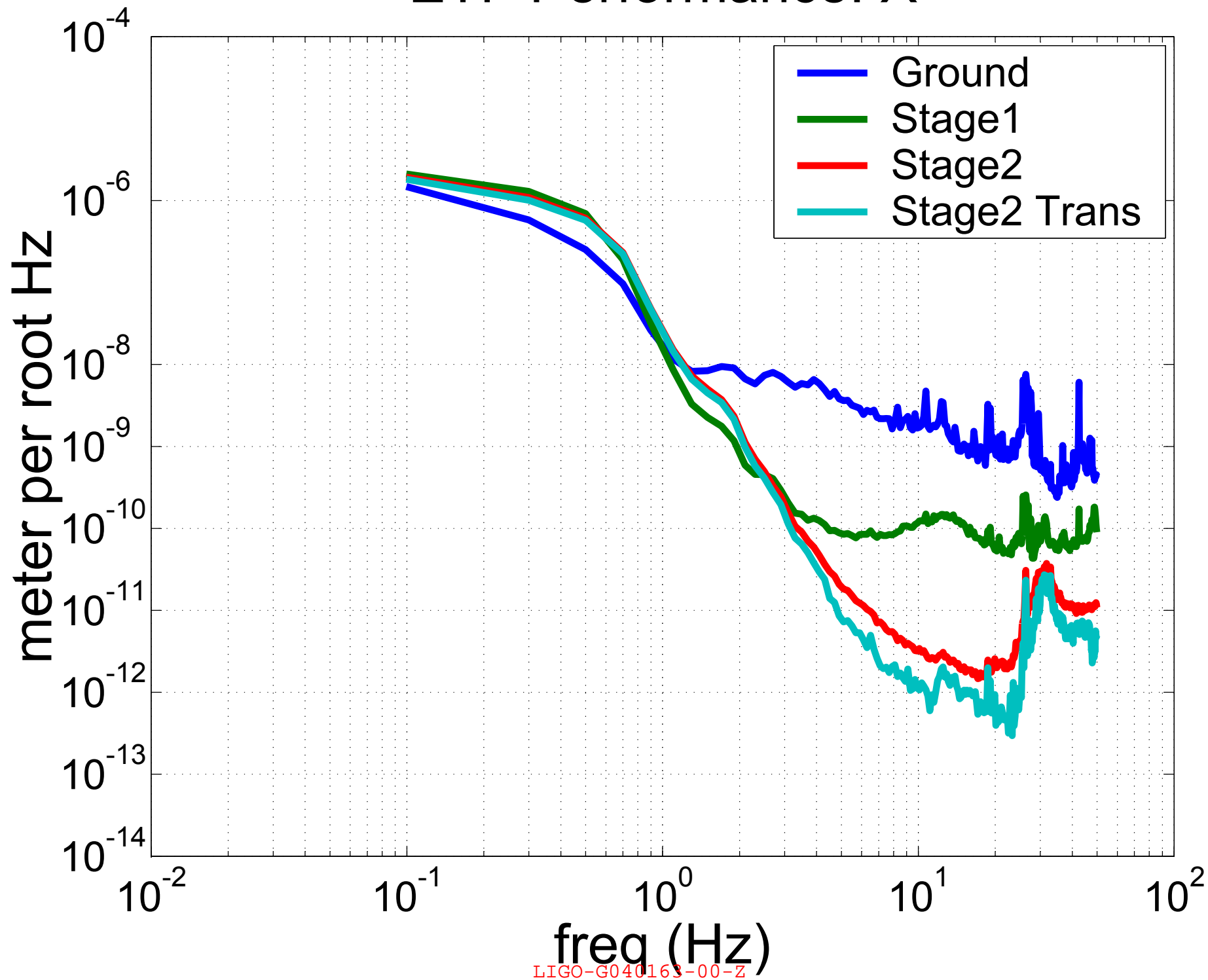

ETF Performance: Y

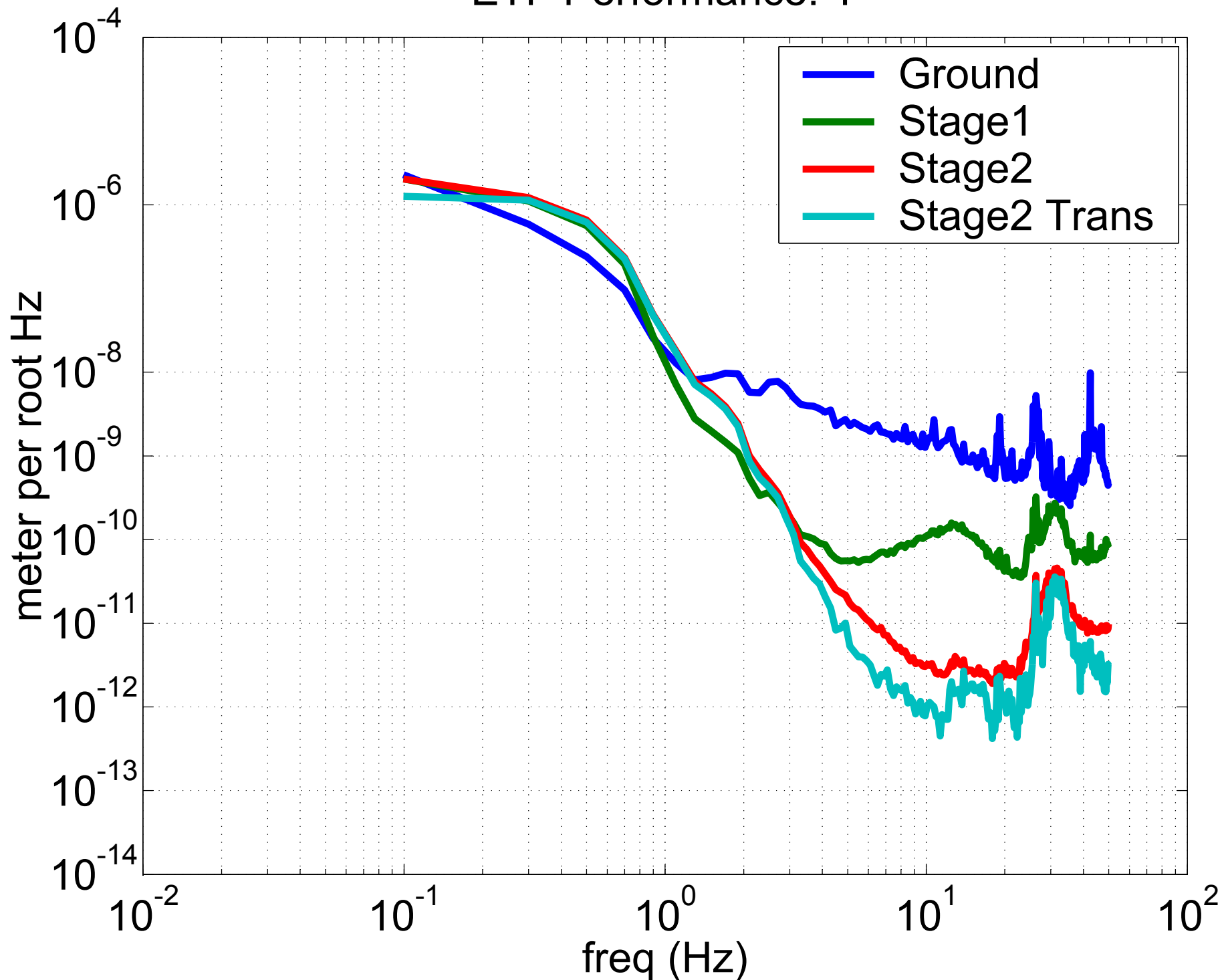

ETF Performance: Z

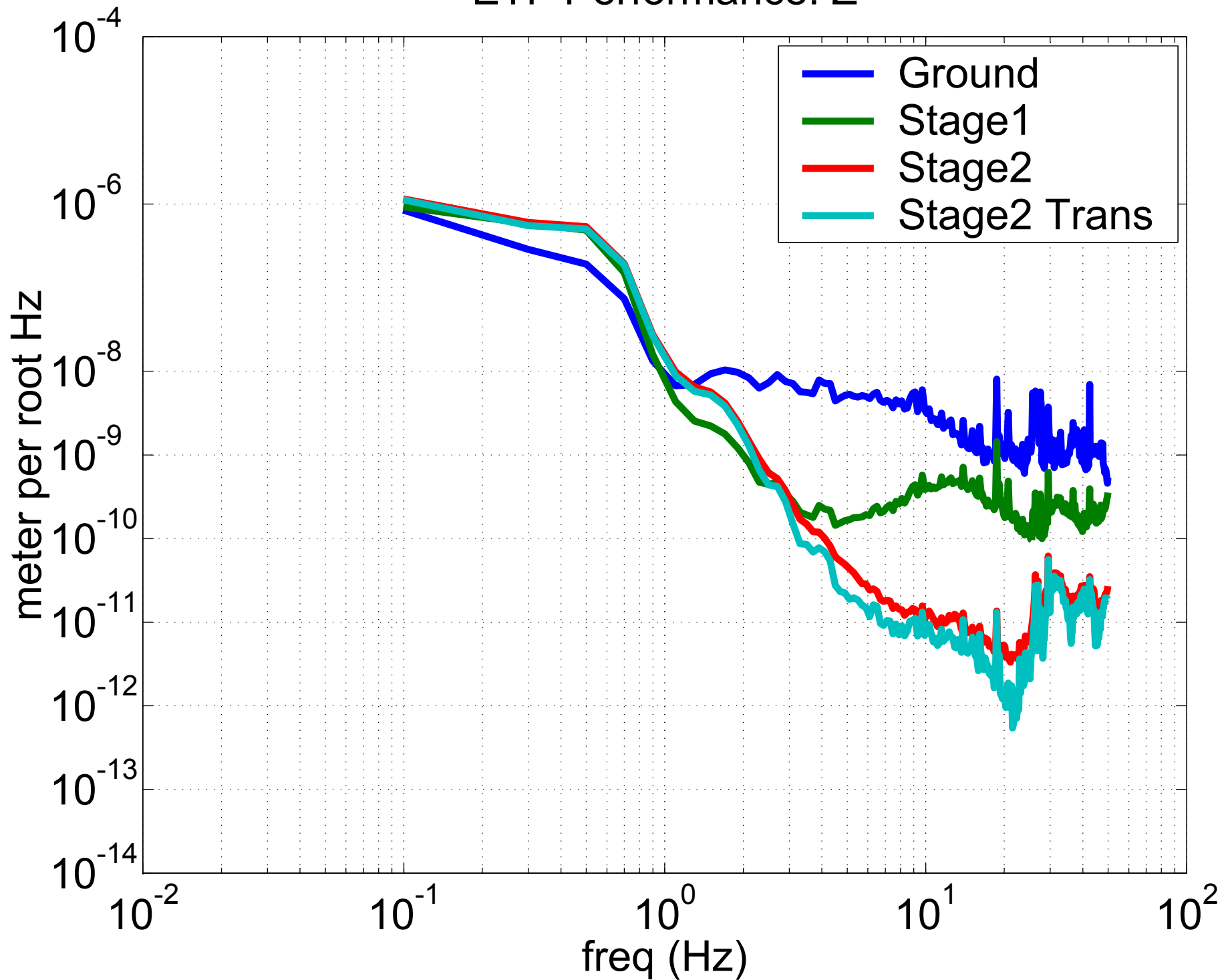

ETF Isolation Factor: X

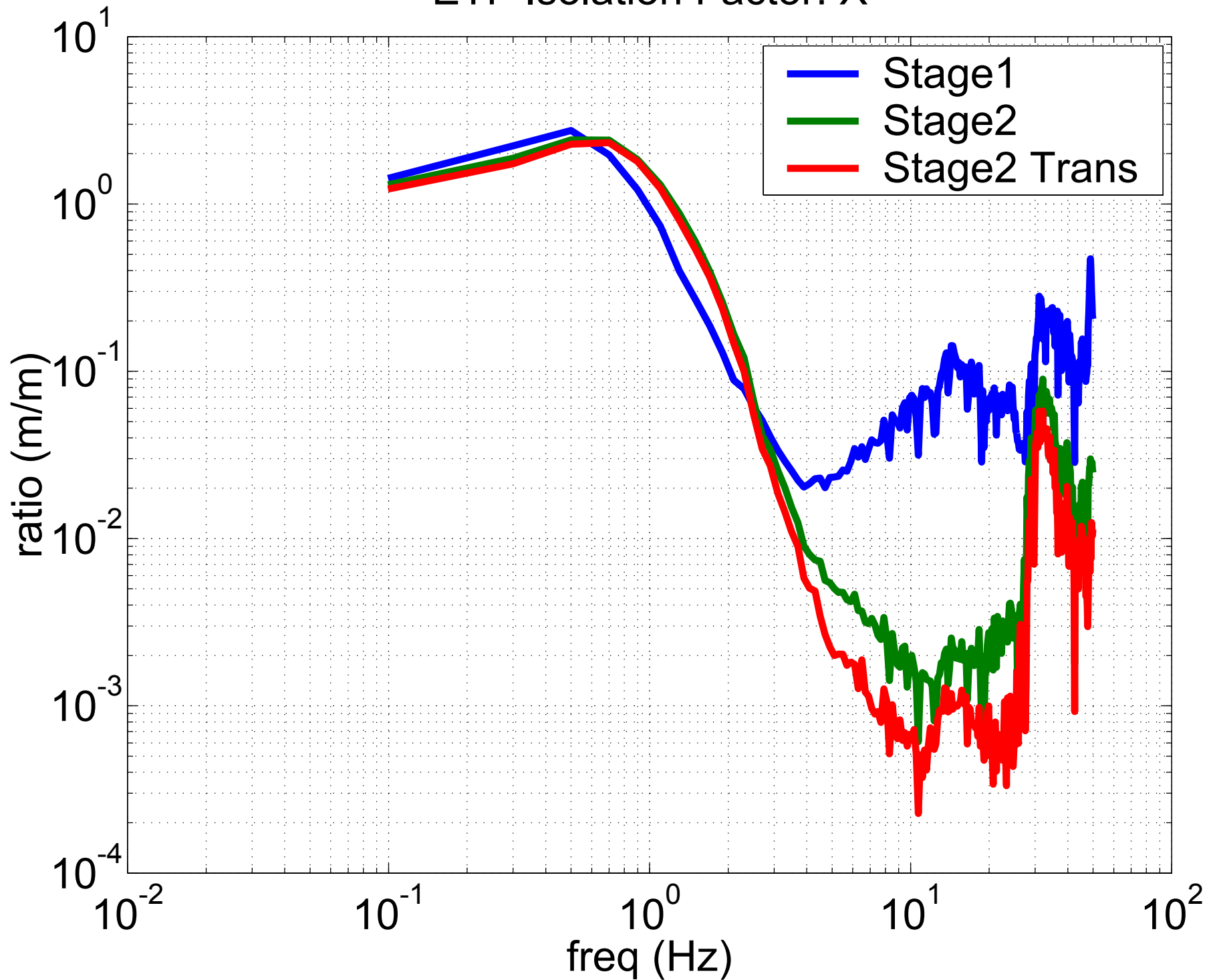

ETF Isolation Factor: Z

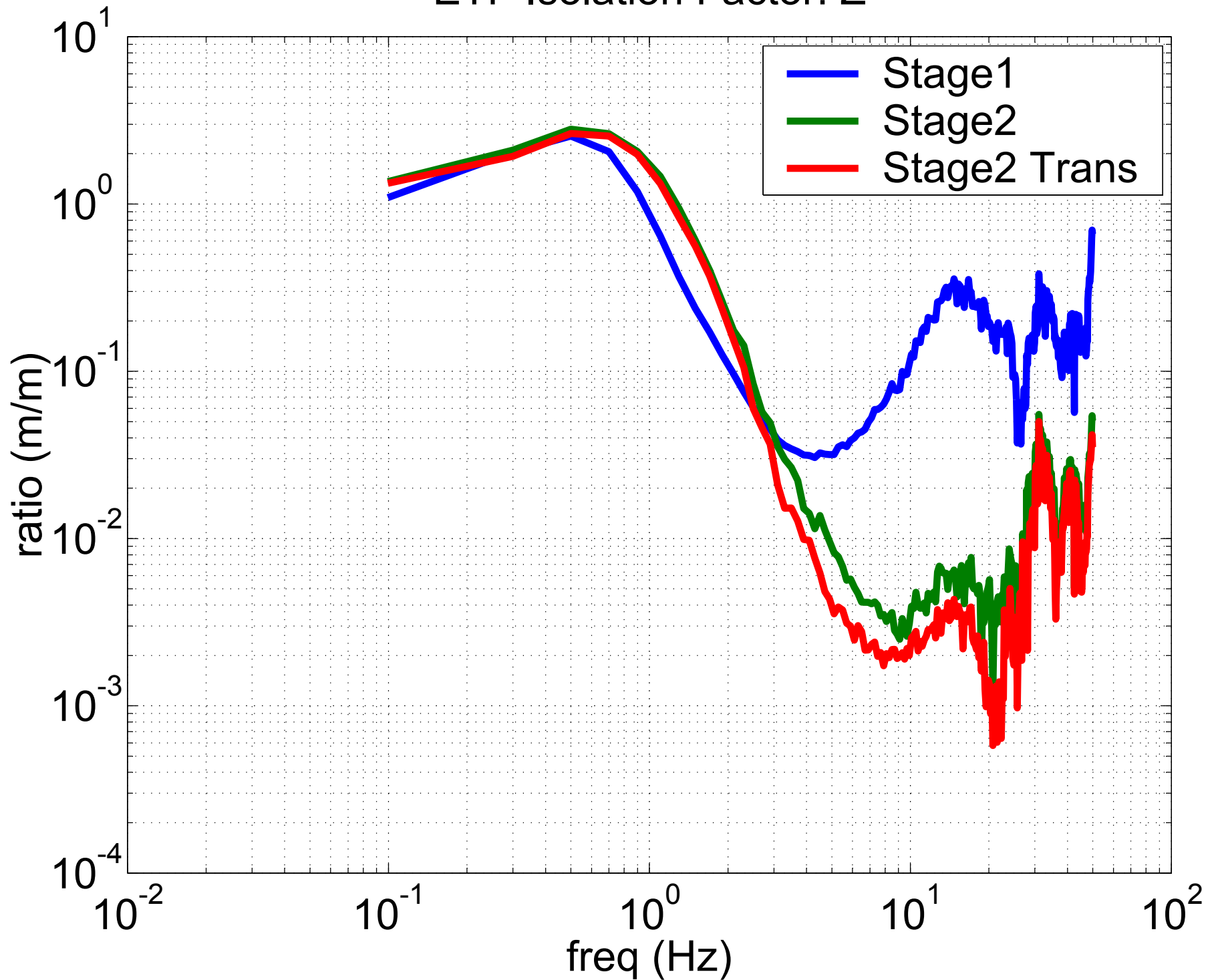

Several Problems Delayed Us

- Broken Actuator
- 12 ADE Position sensors would not work together
- Switcher DC power supply generates noise for GS13.



Things To Do

- Sensor Correction.
- Find the dominating noise sources at 10 Hz.
- Build new actuator drivers with lower noise.
- Identify the vibration mode at about 100 Hz.
- Go vacuum.

Summary

- All 30 sensors, 12 actuators and the rest of the system are working together.
- 27 control loops are closed on the 12 DOF system.
- Horizontal isolation factor of 500 at 10Hz.
- Vertical isolation factor of 300 at 10Hz.
- Hope the to-do list can be done soon.