
Status & Plans for LIGO

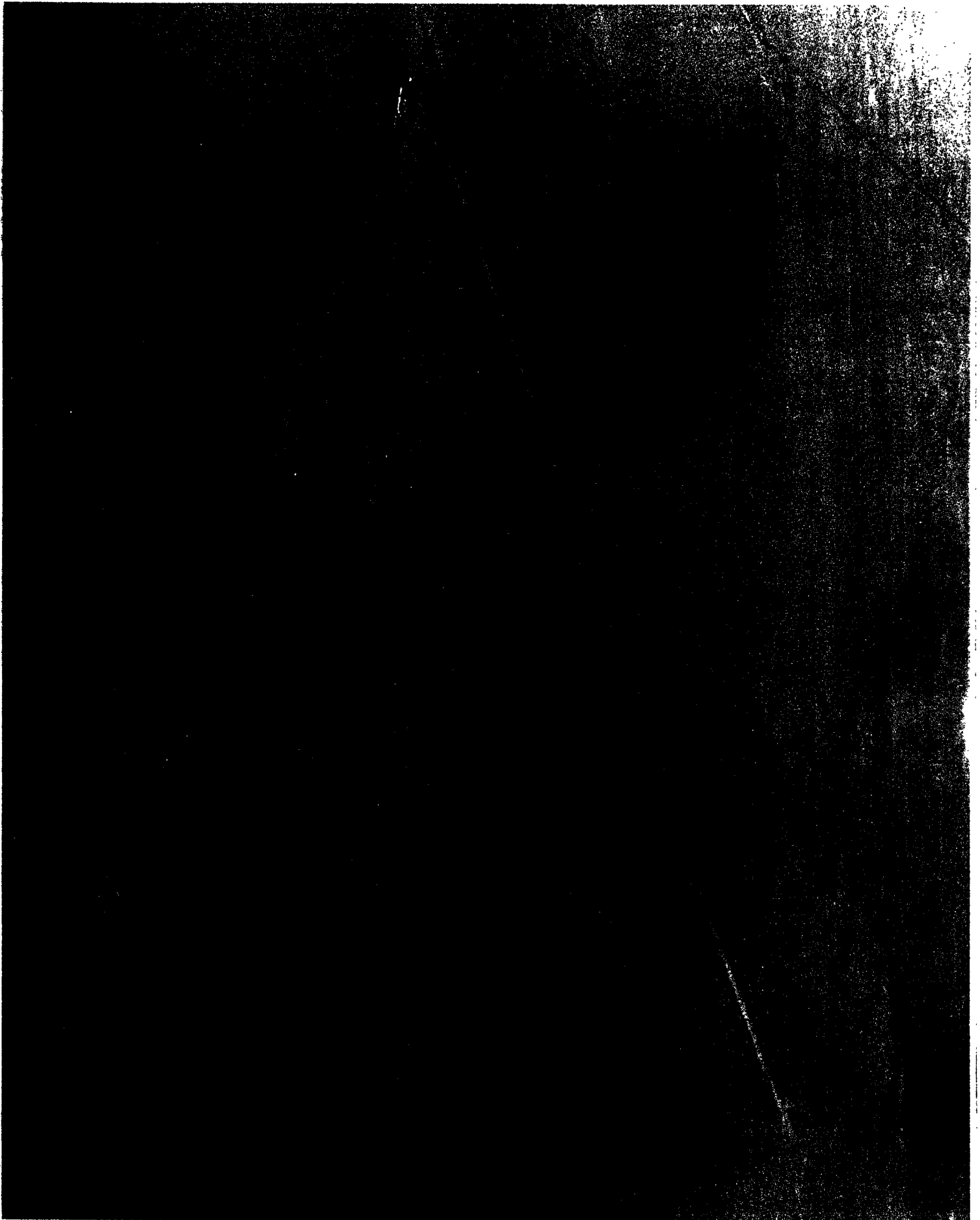
Barry Barish
TAMA Workshop
Nov 13, 1996

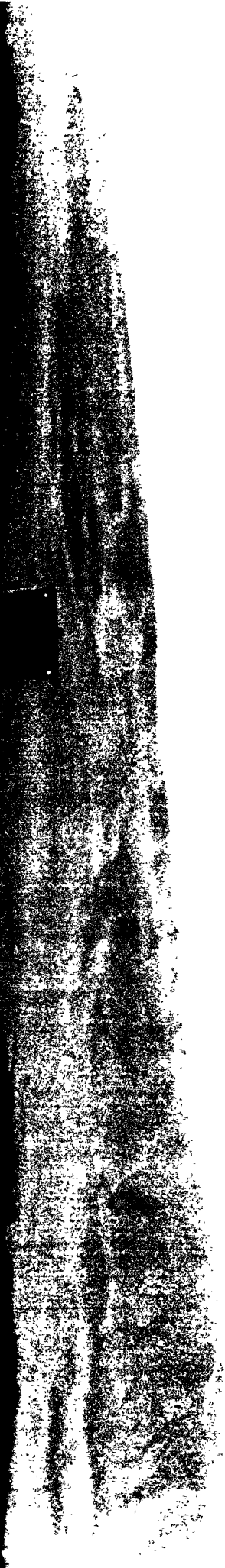
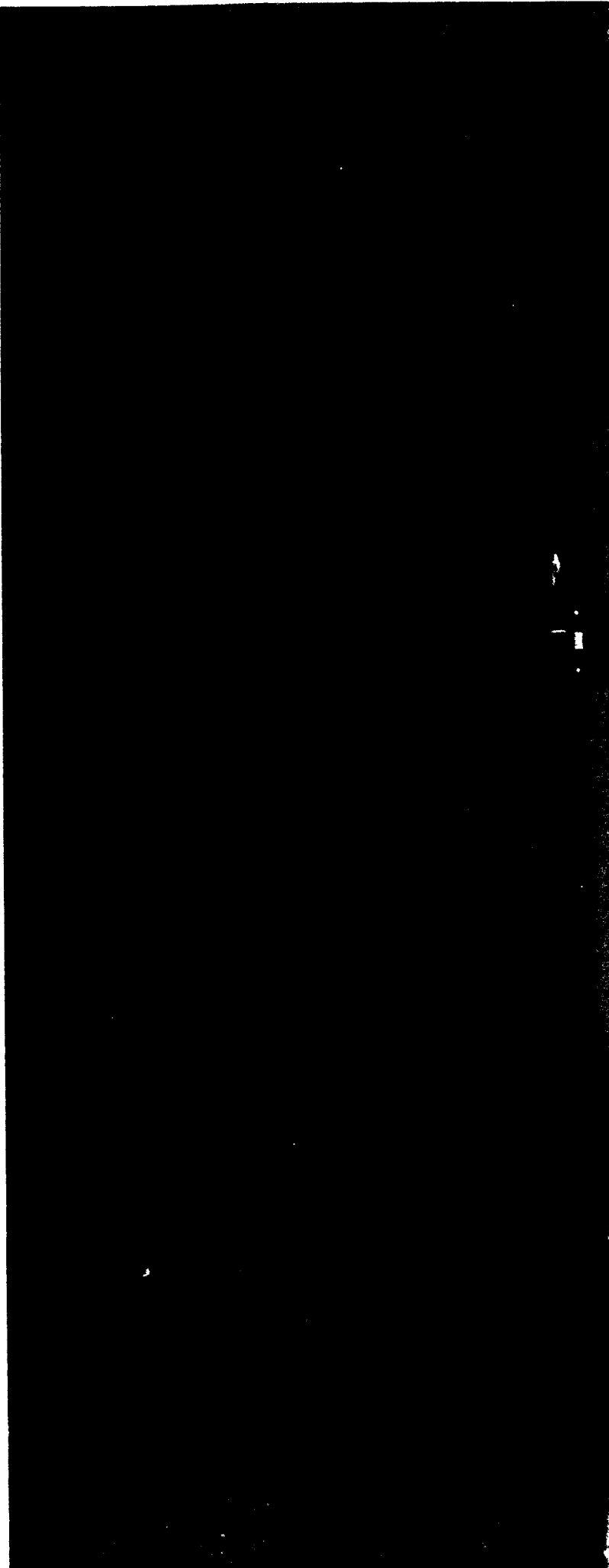


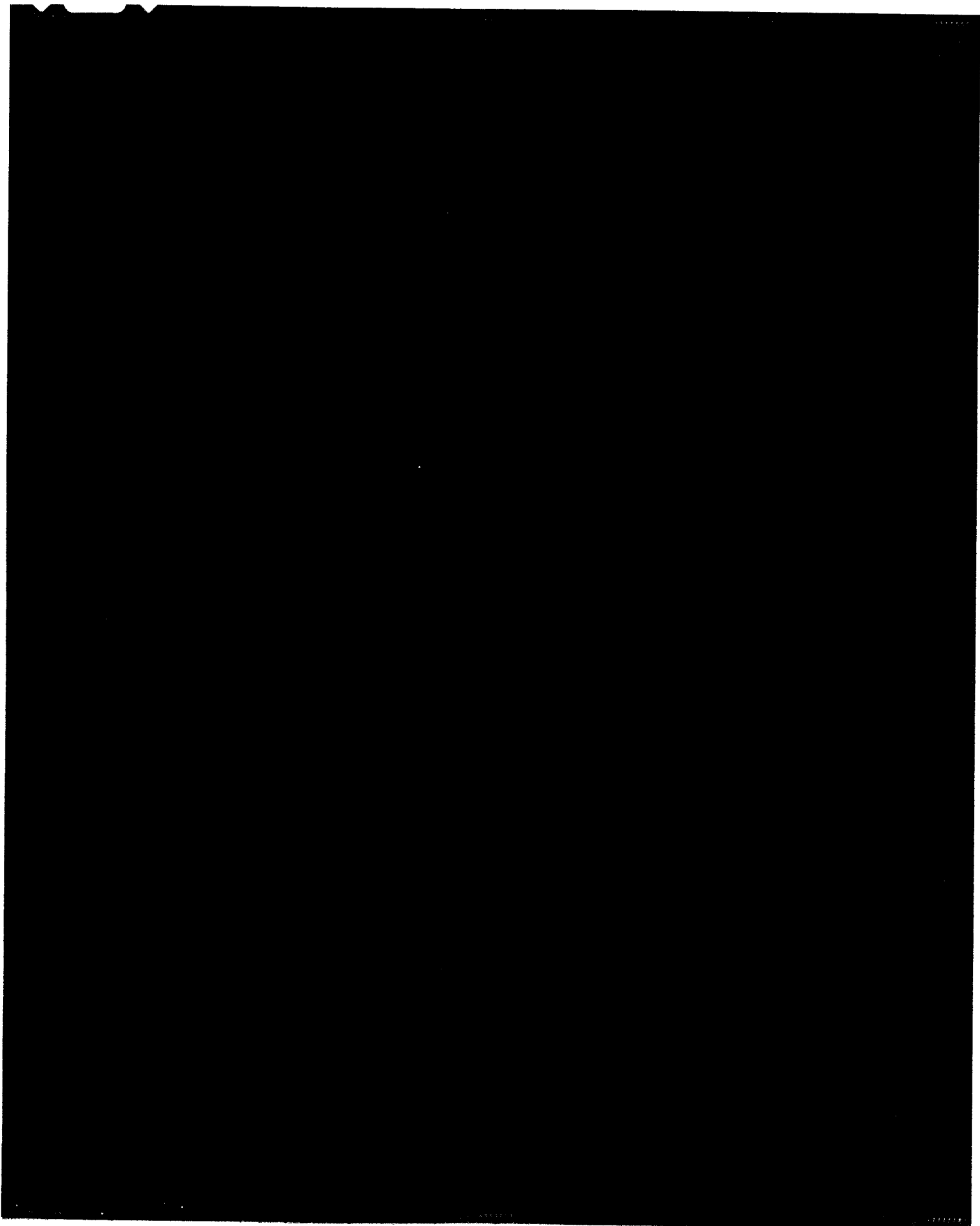
Civil Construction

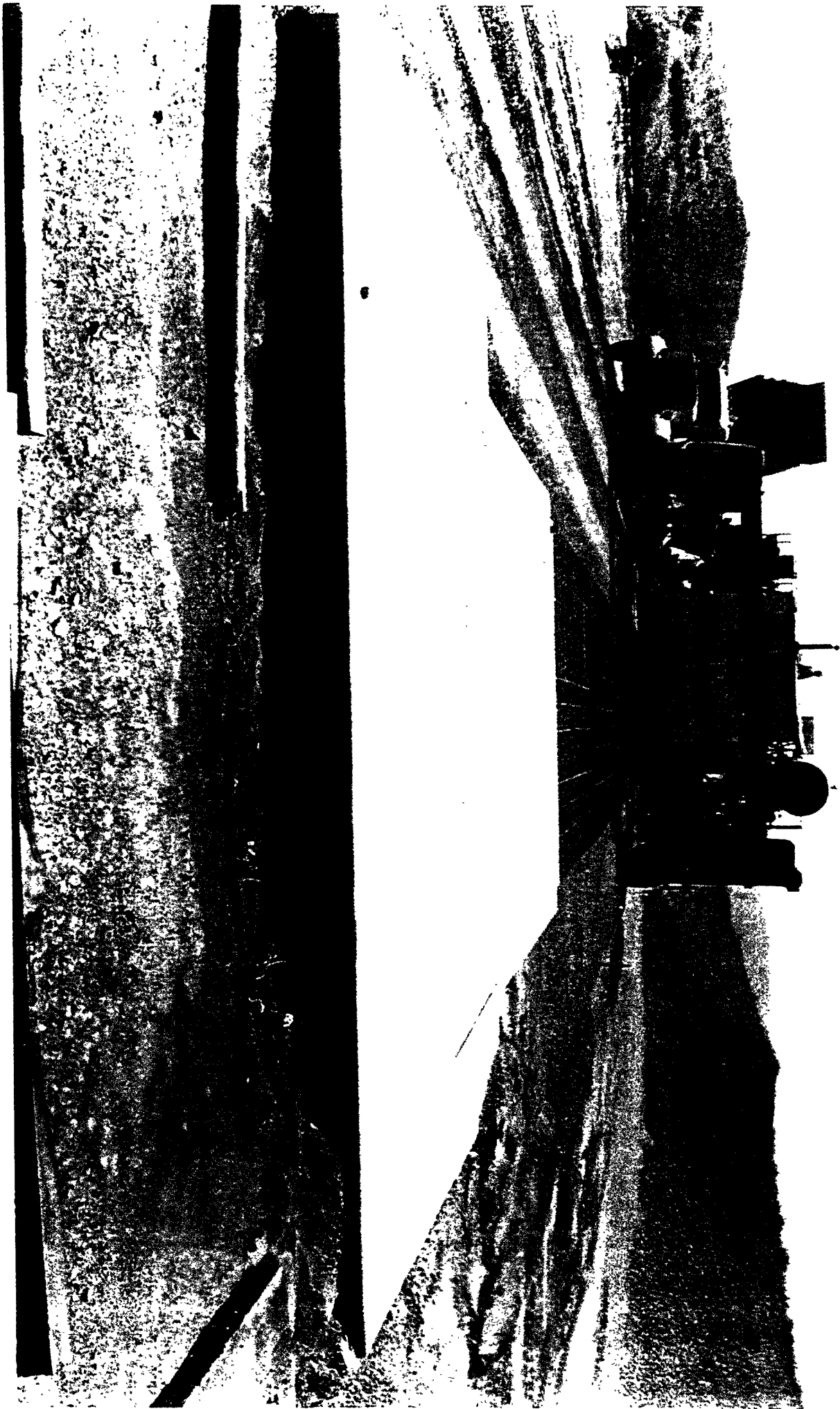
◆ WA site

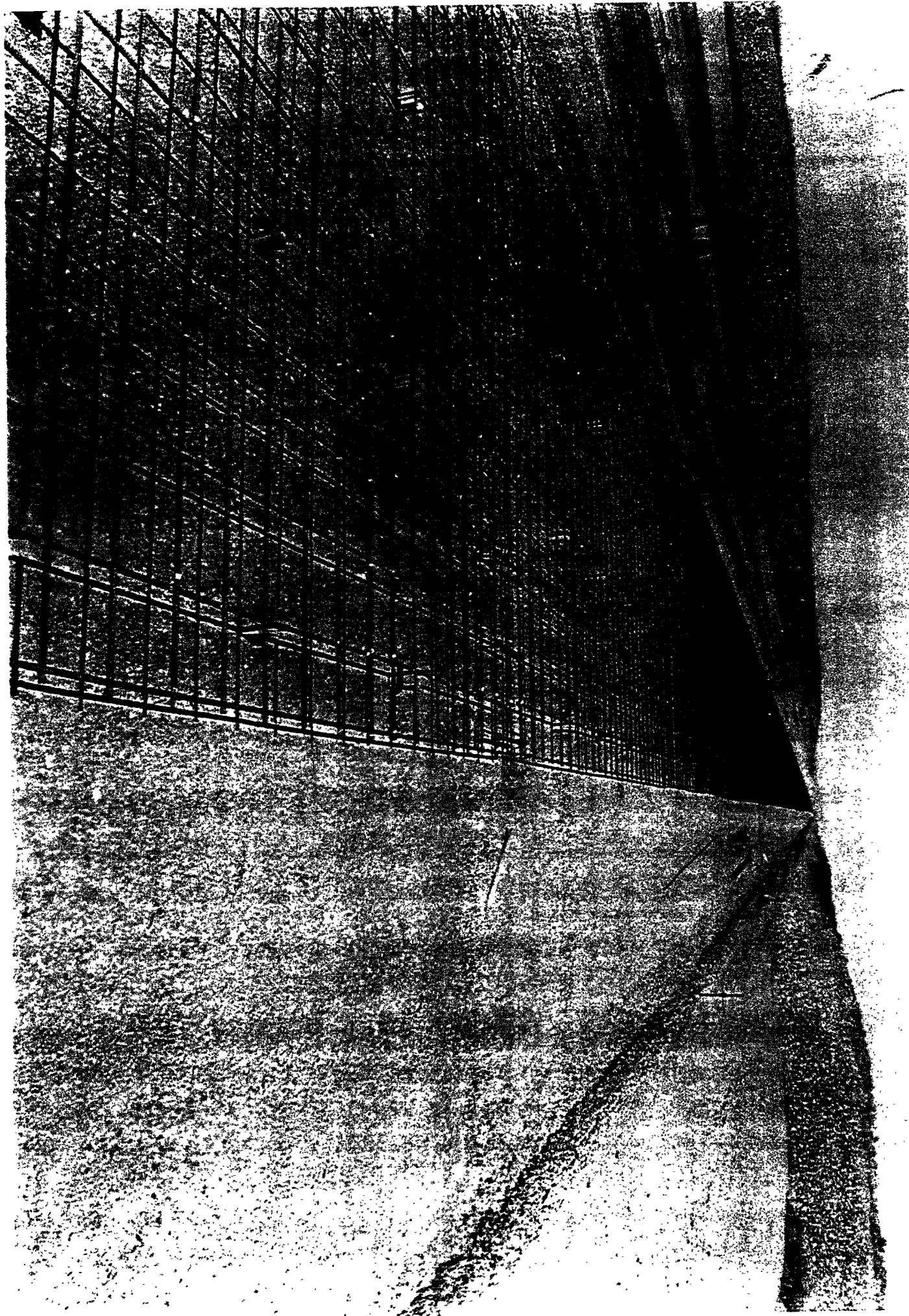
- completed finish grade and slip form of slab
- completed service road and distributed electric power along arms
- Completed precast approx 1500 BT enclosure segments
- demo'd installation technique
- completed final design and initiated construction of WA bldgs
- awarded BT enclosure installation contract

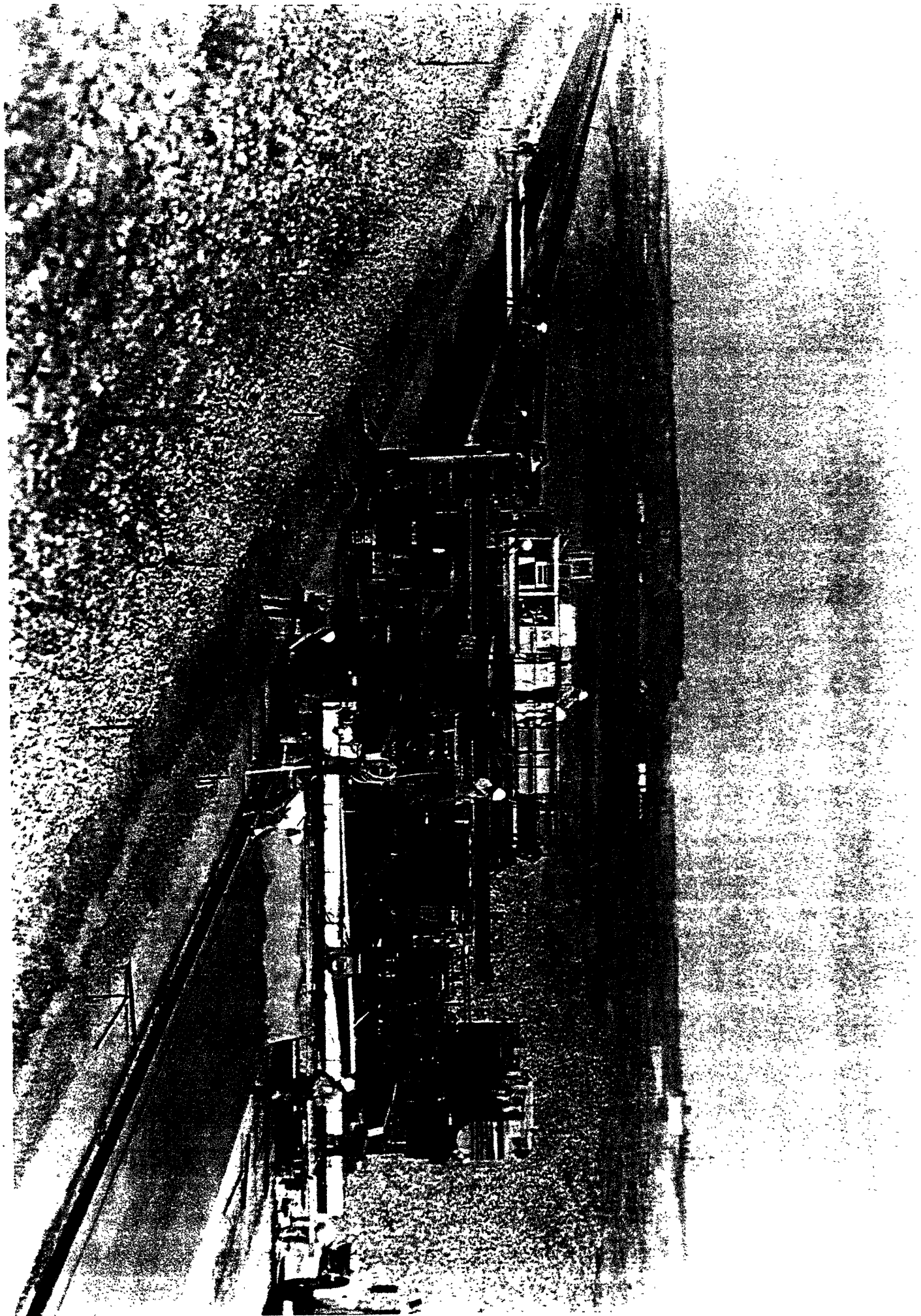


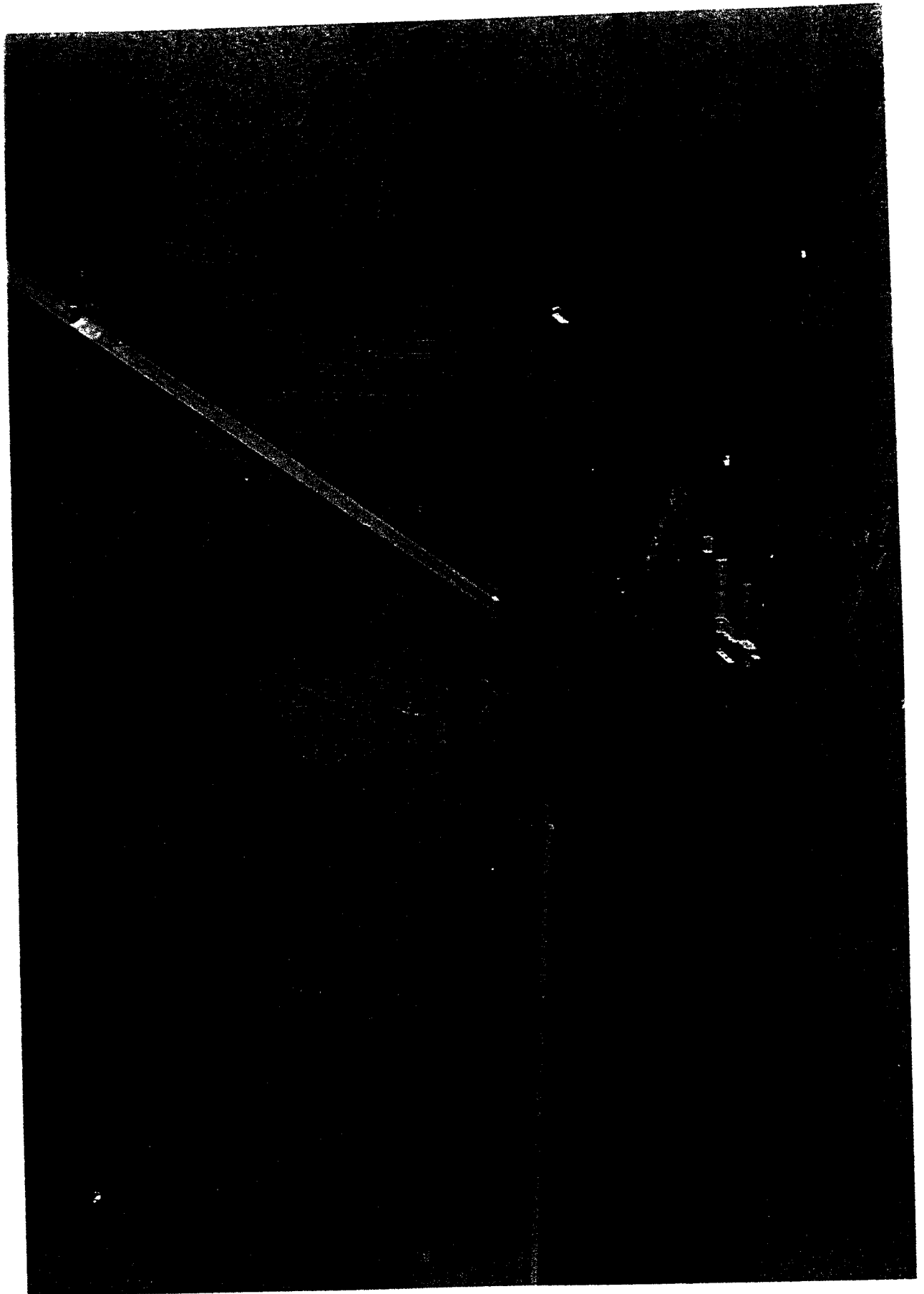








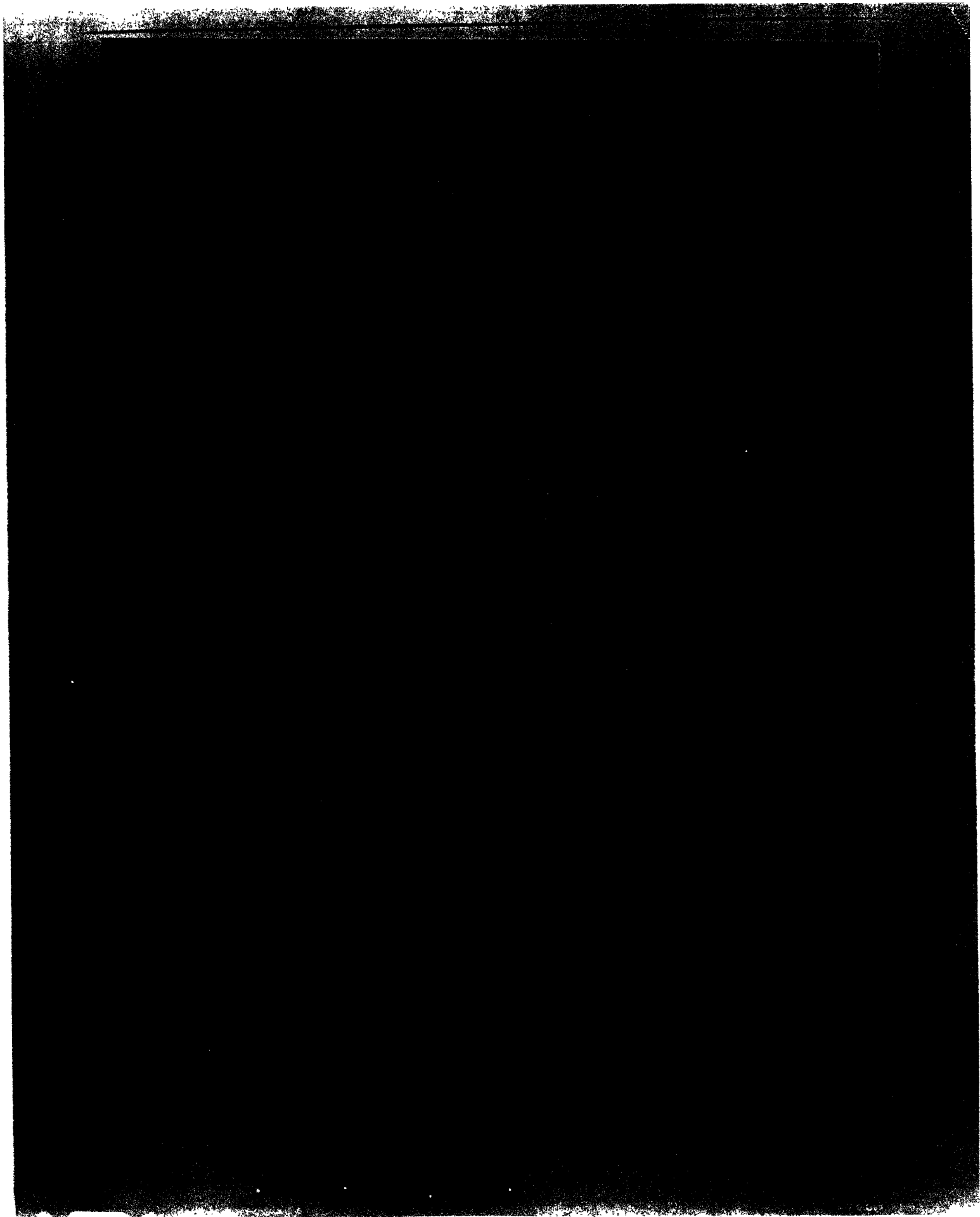




WA bldg status

Otto Matherny

- ◆ Bldg construction status
 - mid and end station footers installed
 - conduit for power and data acquisition and control installed
 - vaults and power for bakeout and site power installed
 - conduits to chiller yards from mid and stations placed.

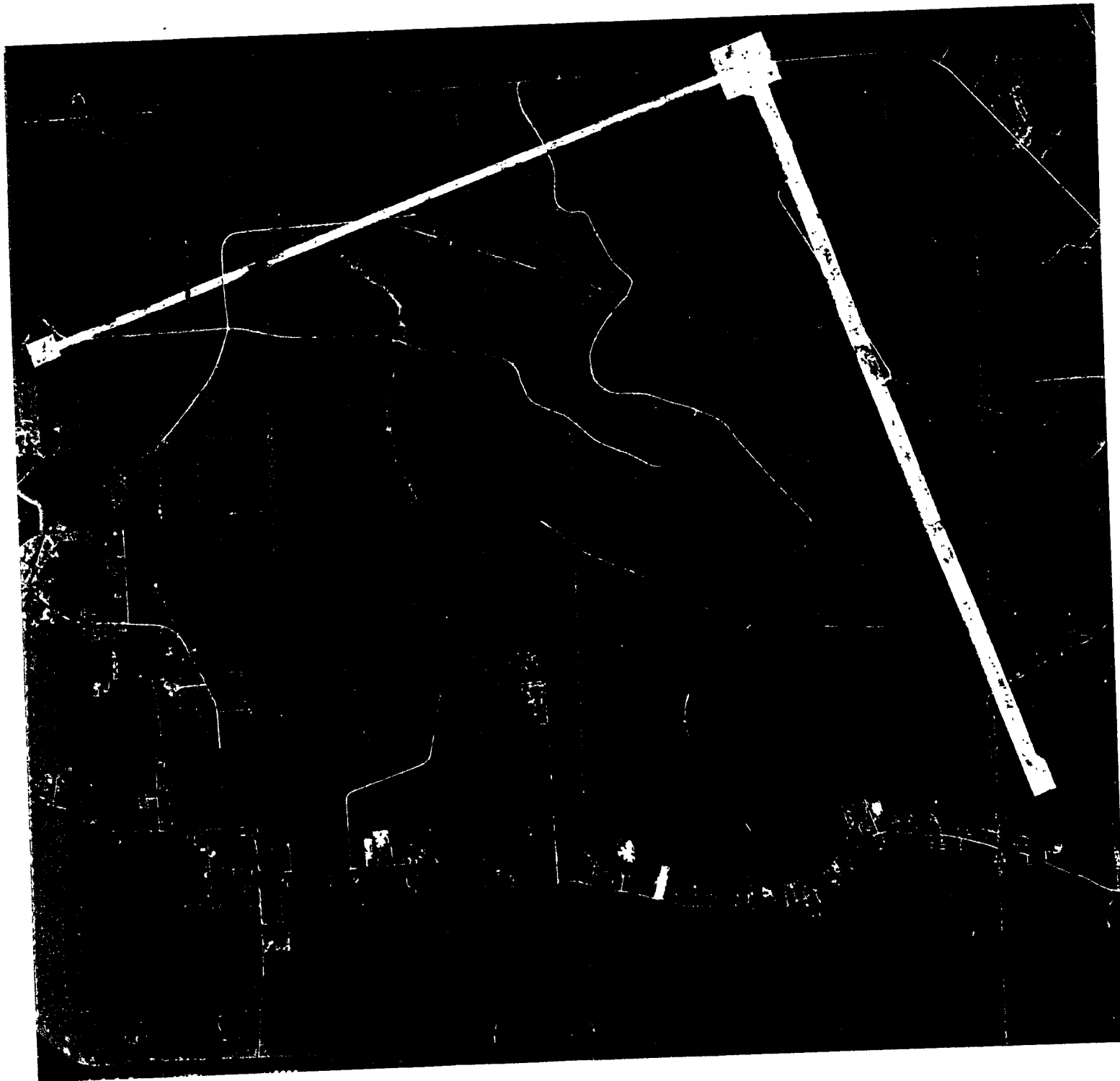




LA Civil Construction Status

Otto Matherny, Fred Asiri

- ◆ Bids opened for slabs, enclosures, roads, buildings
 - apparent low bidders within budget.
- ◆ Rough grading:
 - It rains a lot in LA
 - approximately 150 days lost to weather delay
 - arms at full height since July
 - » should allow-sufficient time for settlement for Feb 97 slab installation
 - » monitoring of settlement plates to look at creep rate.



LIGO

LIVINGSTON PARISH

LOUISIANA

1A

AERIAL PHOTO BY:

GULF COAST AERIAL MAPPING

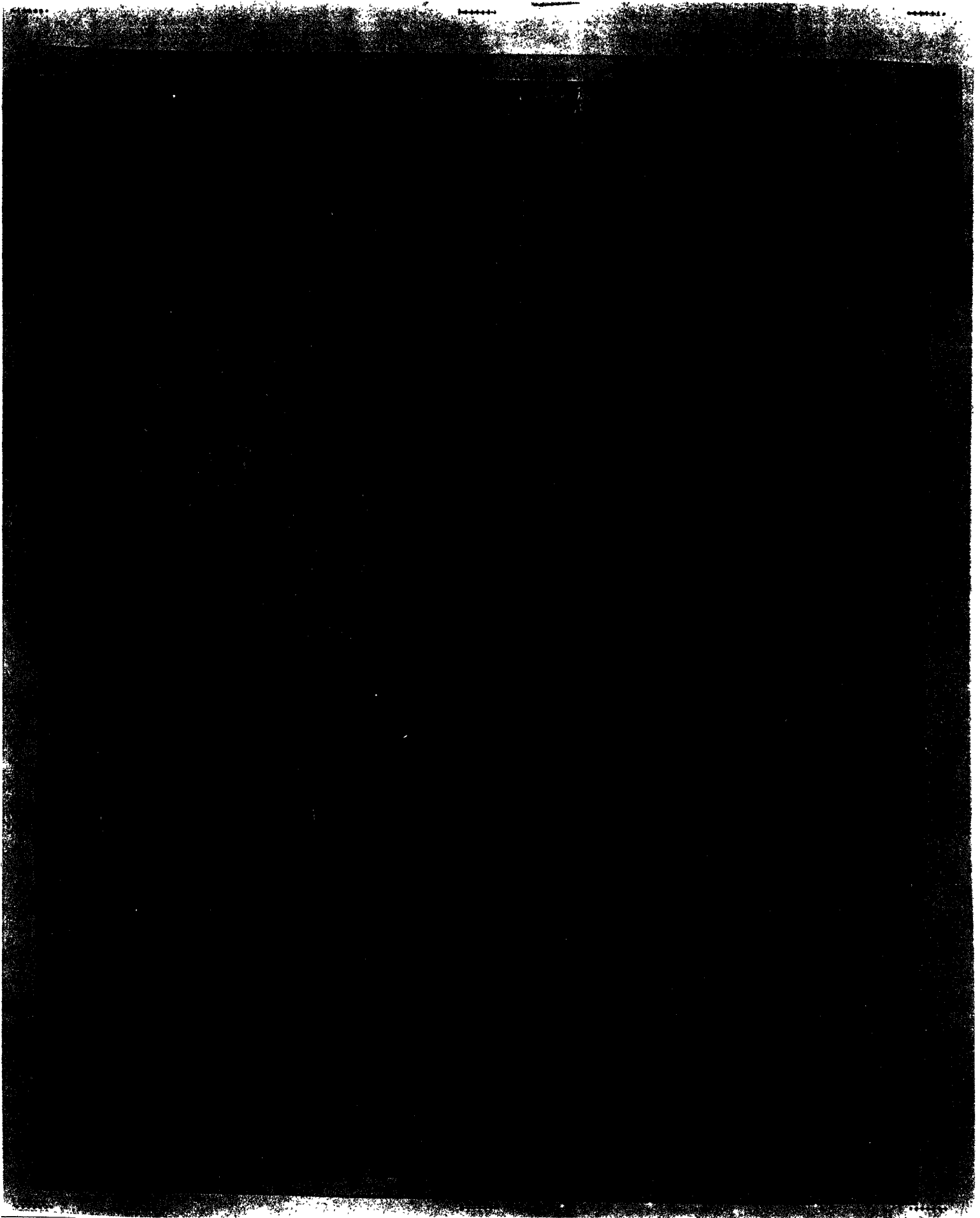
FLOWN: AUGUST 25, 1995

ALTITUDE: 12,000 FEET

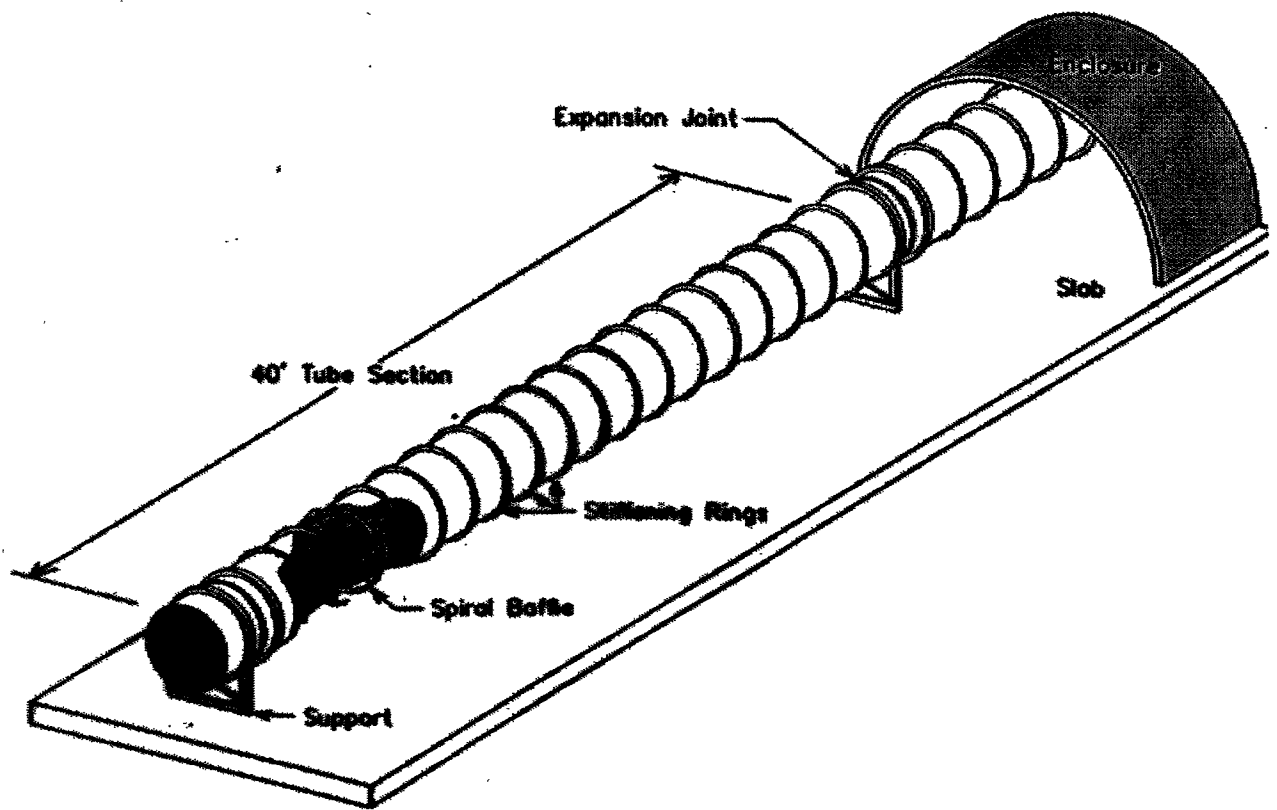


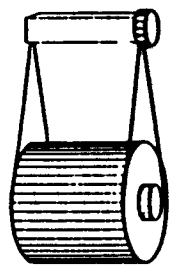
G960028-17-O-V



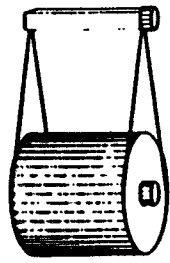


Beam Tube





1



2



3



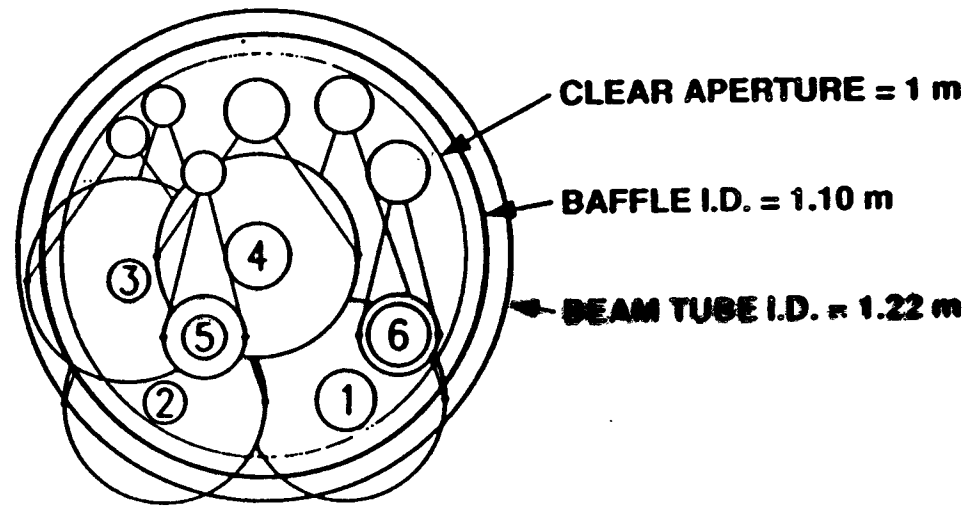
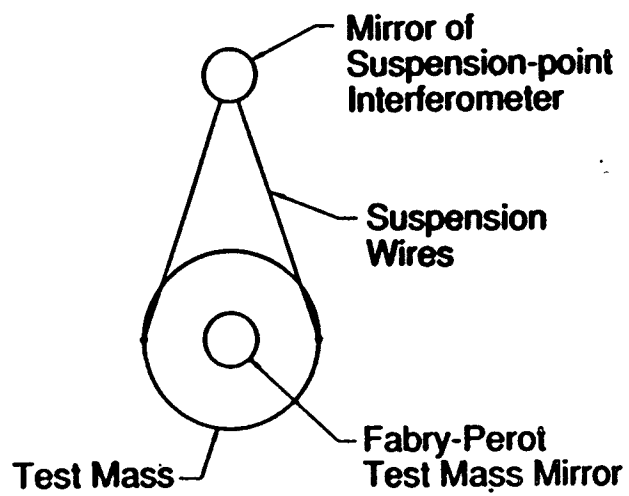
4



5

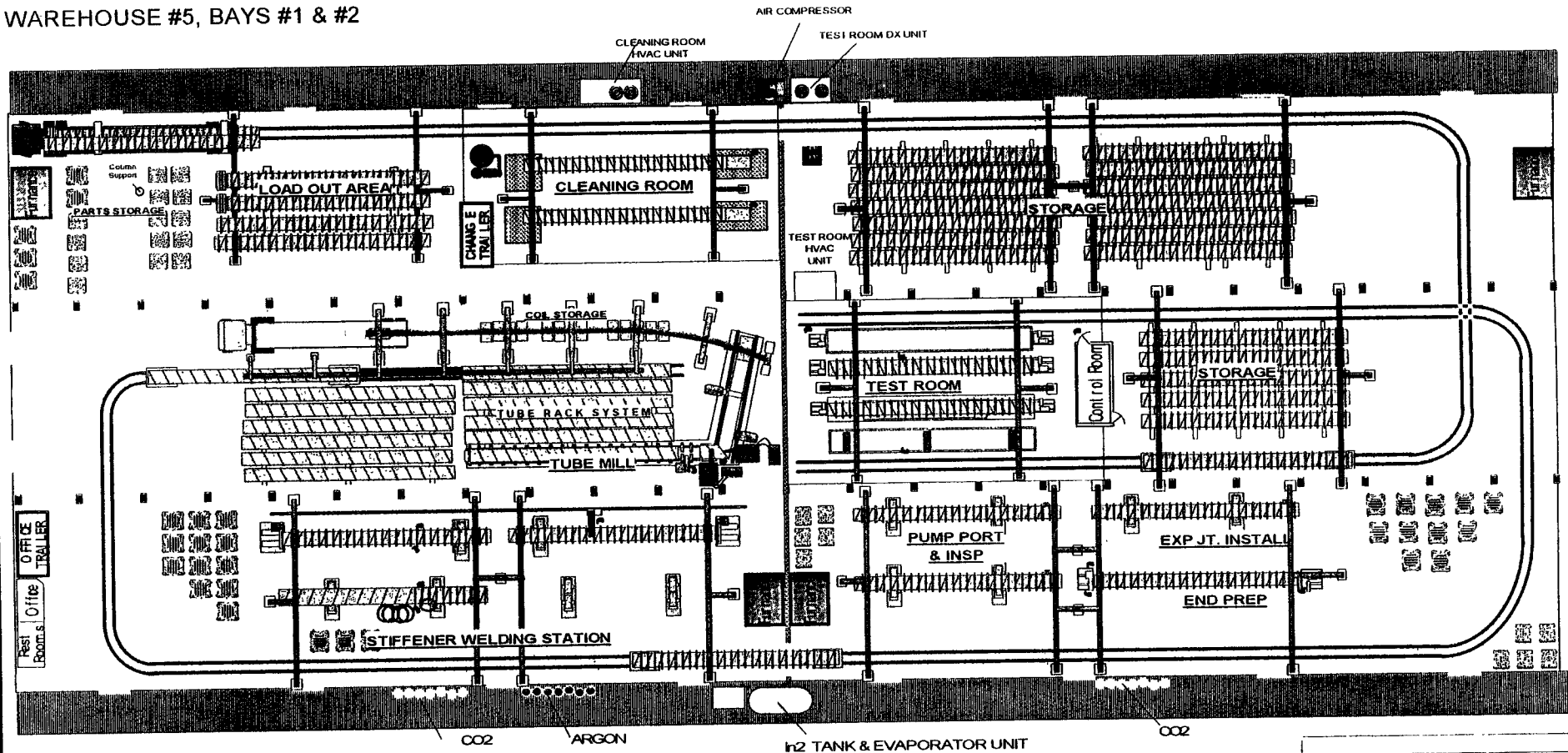


6



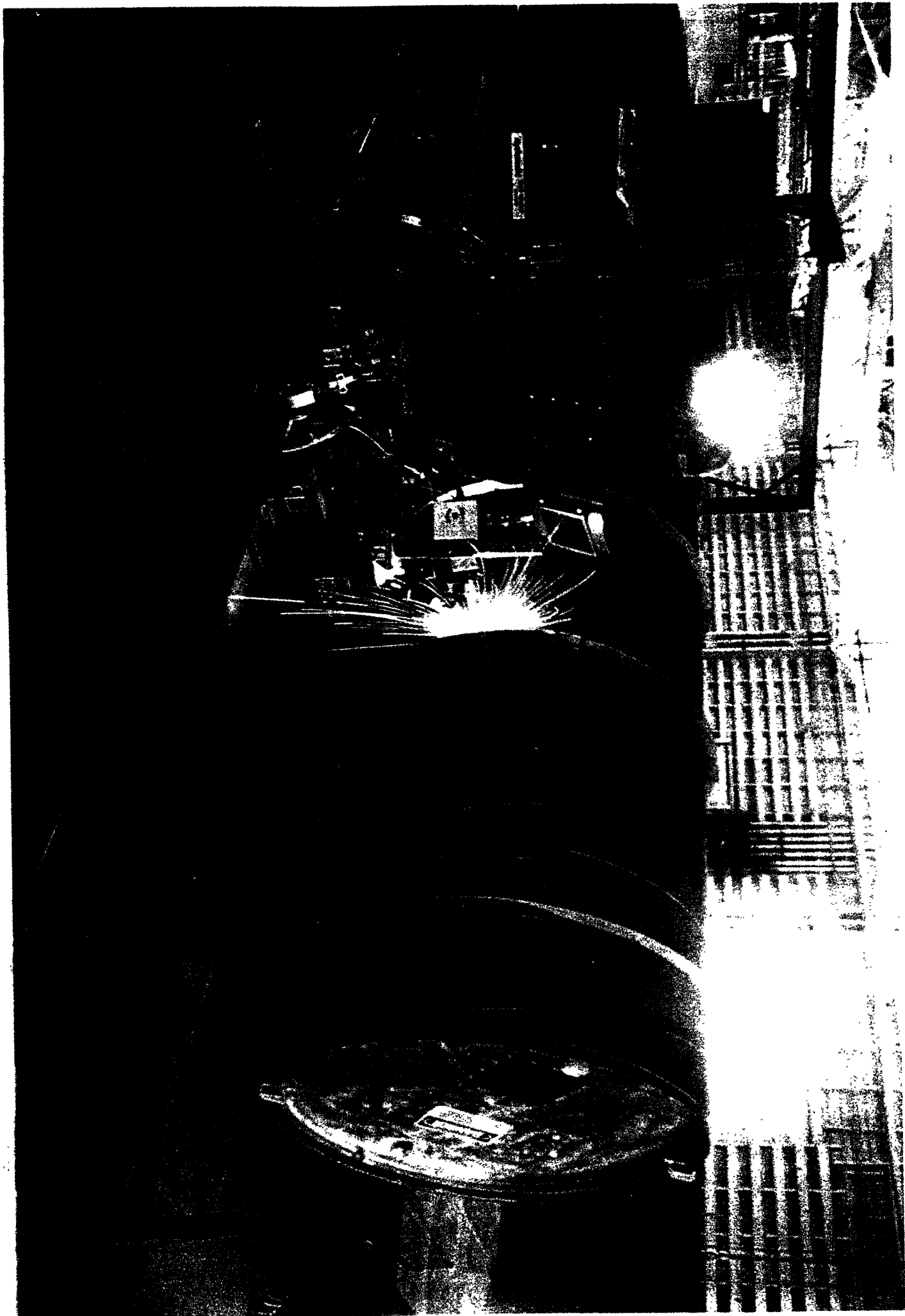
BIG PASCO

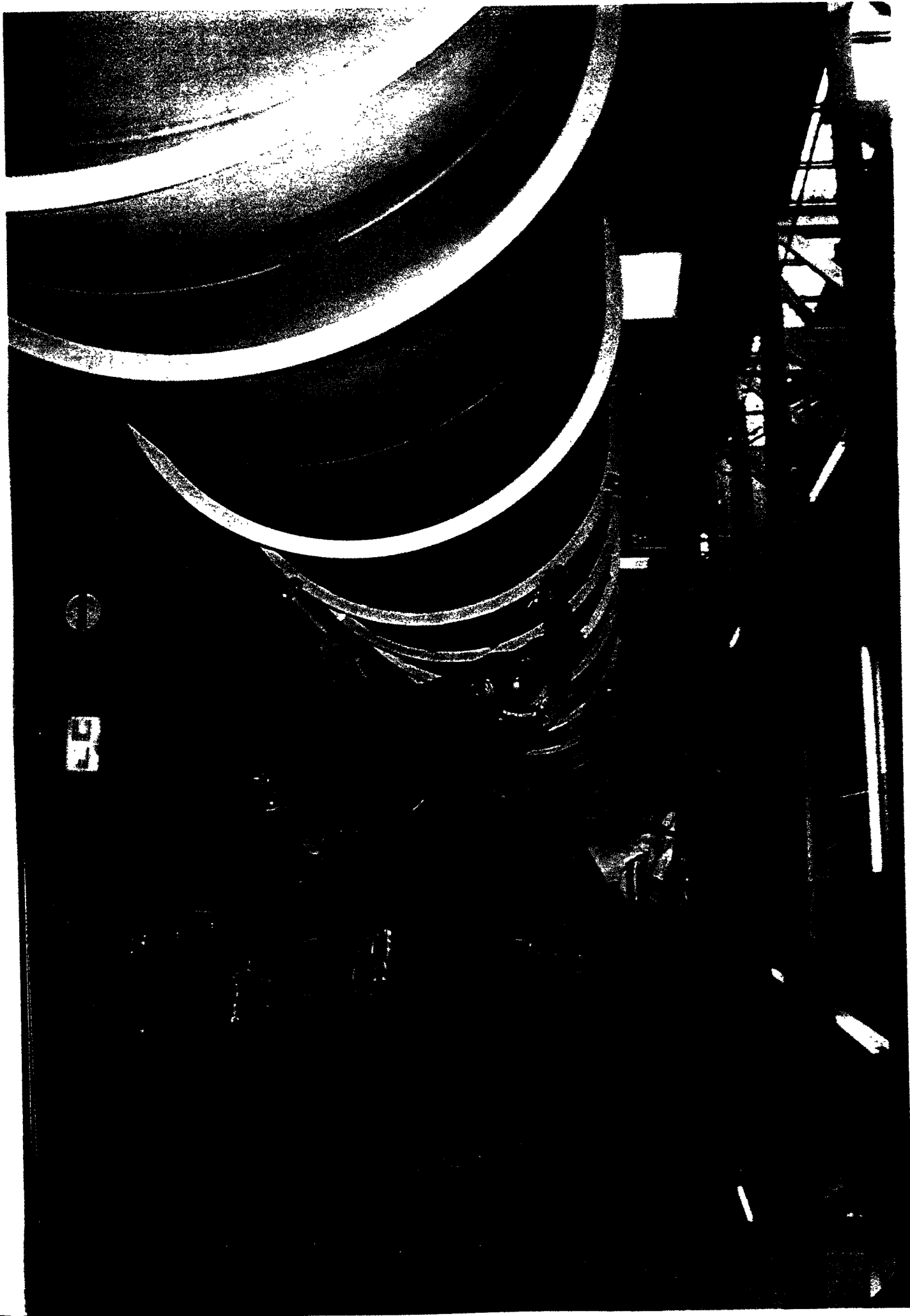
WAREHOUSE #5, BAYS #1 & #2

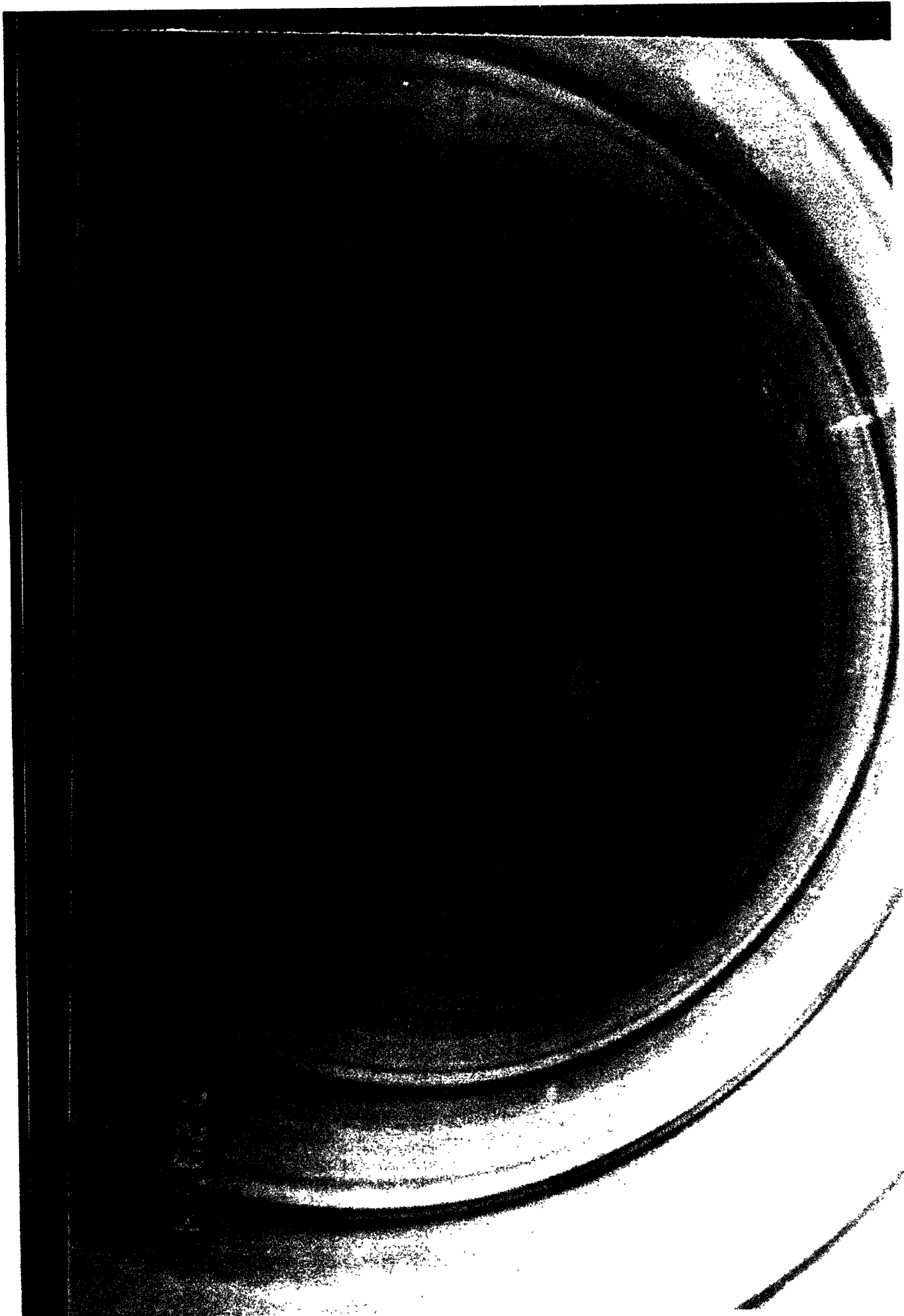


		LASER INTERFEROMETER OPERATOR	
		OBSERVATOR	
HANFORD LOCATION FABRICATION FACILITY BIG PASCO WHSE #5, BAYS 1 & 2			
Equipment ID: PC181520		950674	
By: _____ Date: _____		Obs: _____ Re: _____	
Equipment Supervisor: _____			
Project: BIGPAS01.CVS			

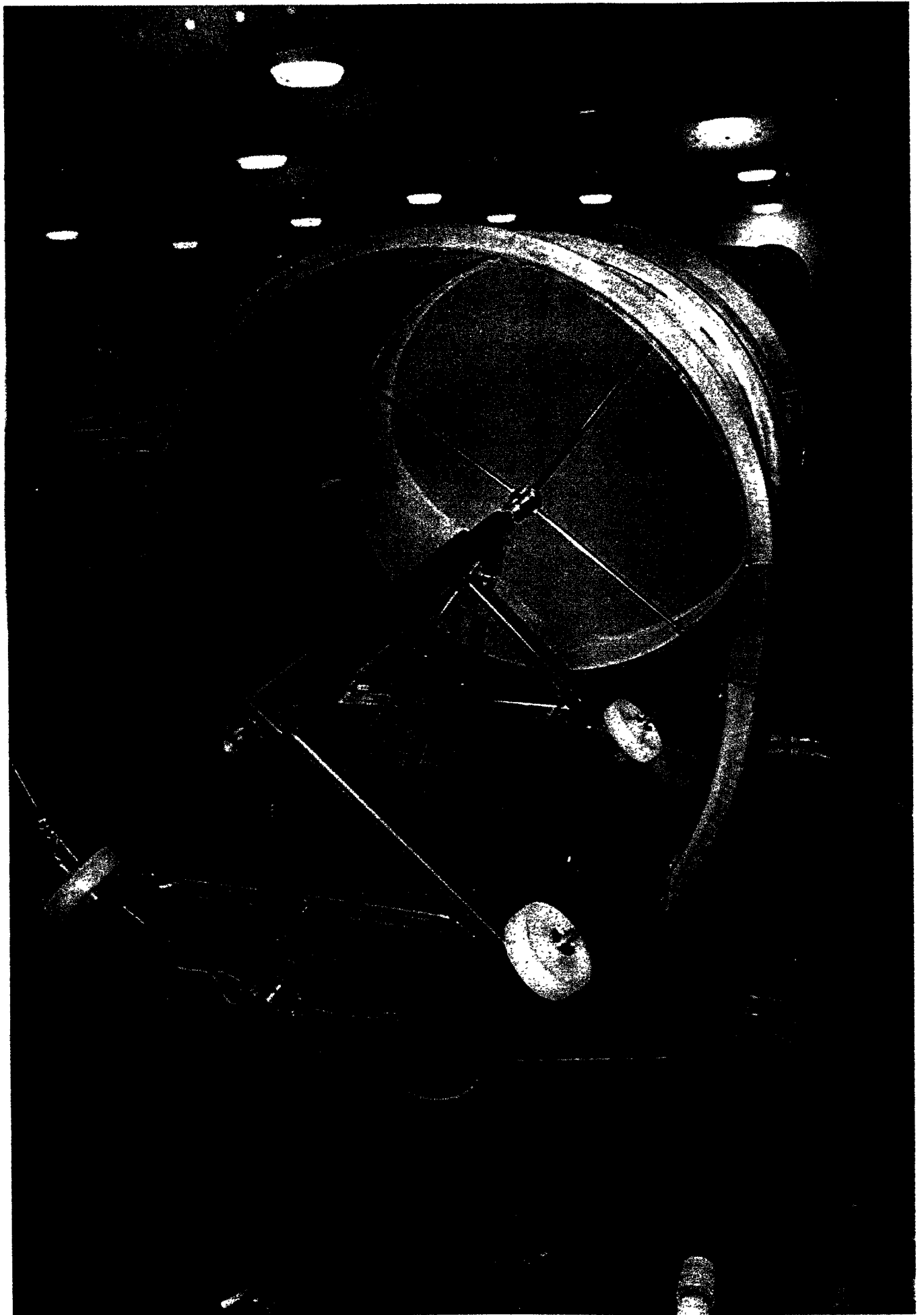


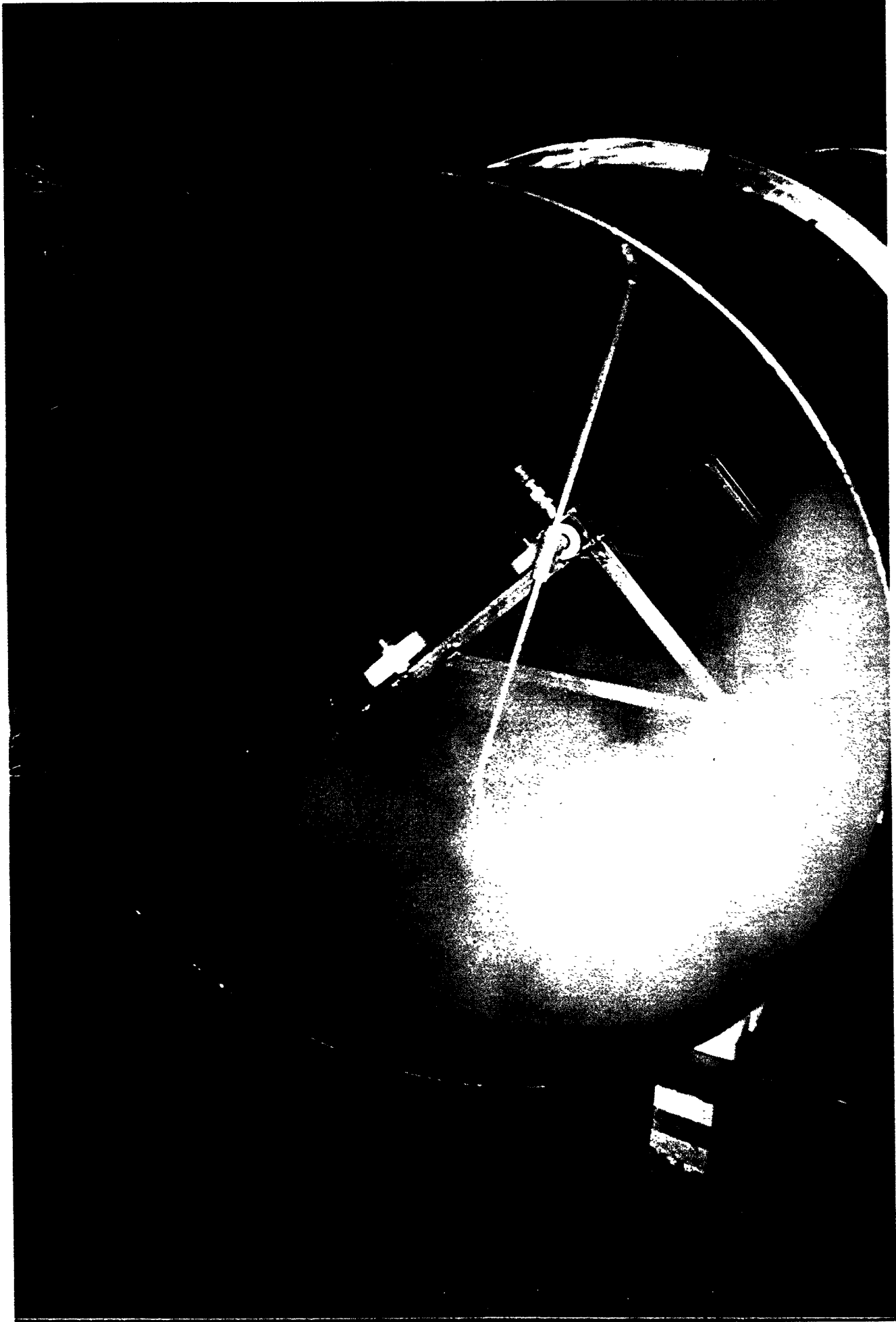




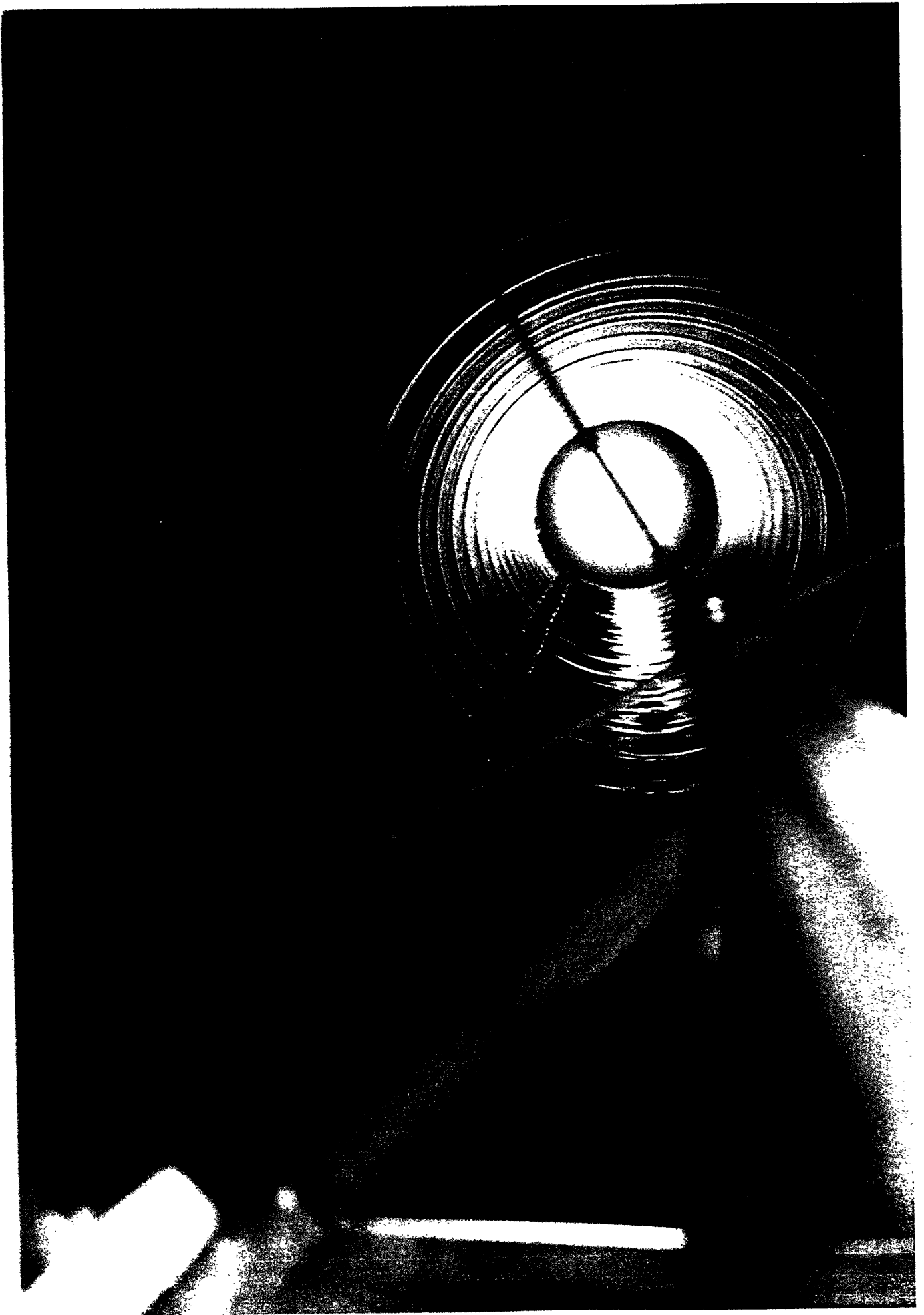








SIEMENS



Beam Tube Enclosure

- ◆ Objective:

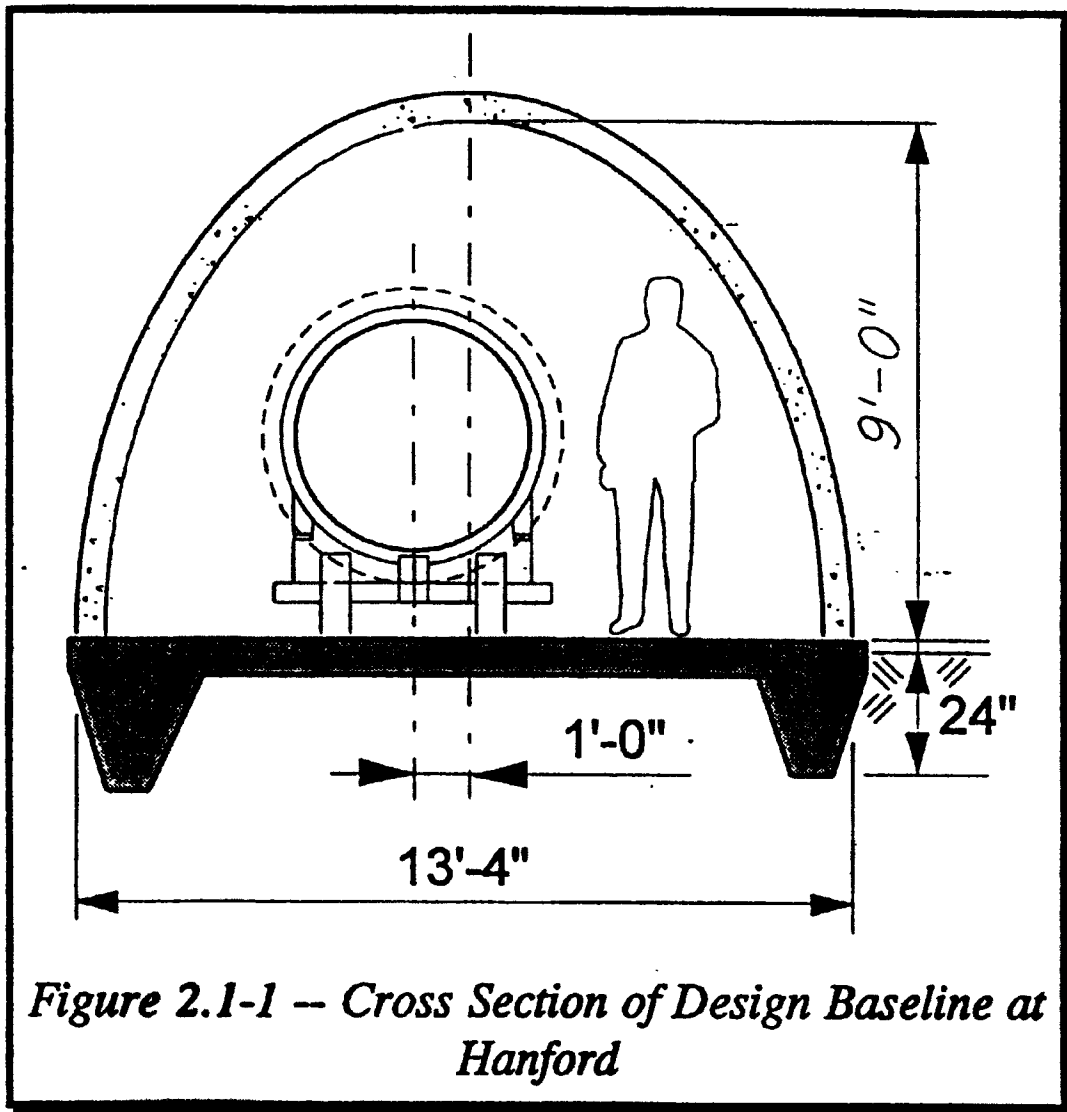
- 700 pre-cast BTE's on site by 9/1
- Installation contract placed to have BTE installer work approx 3-5 sections behind CBI.

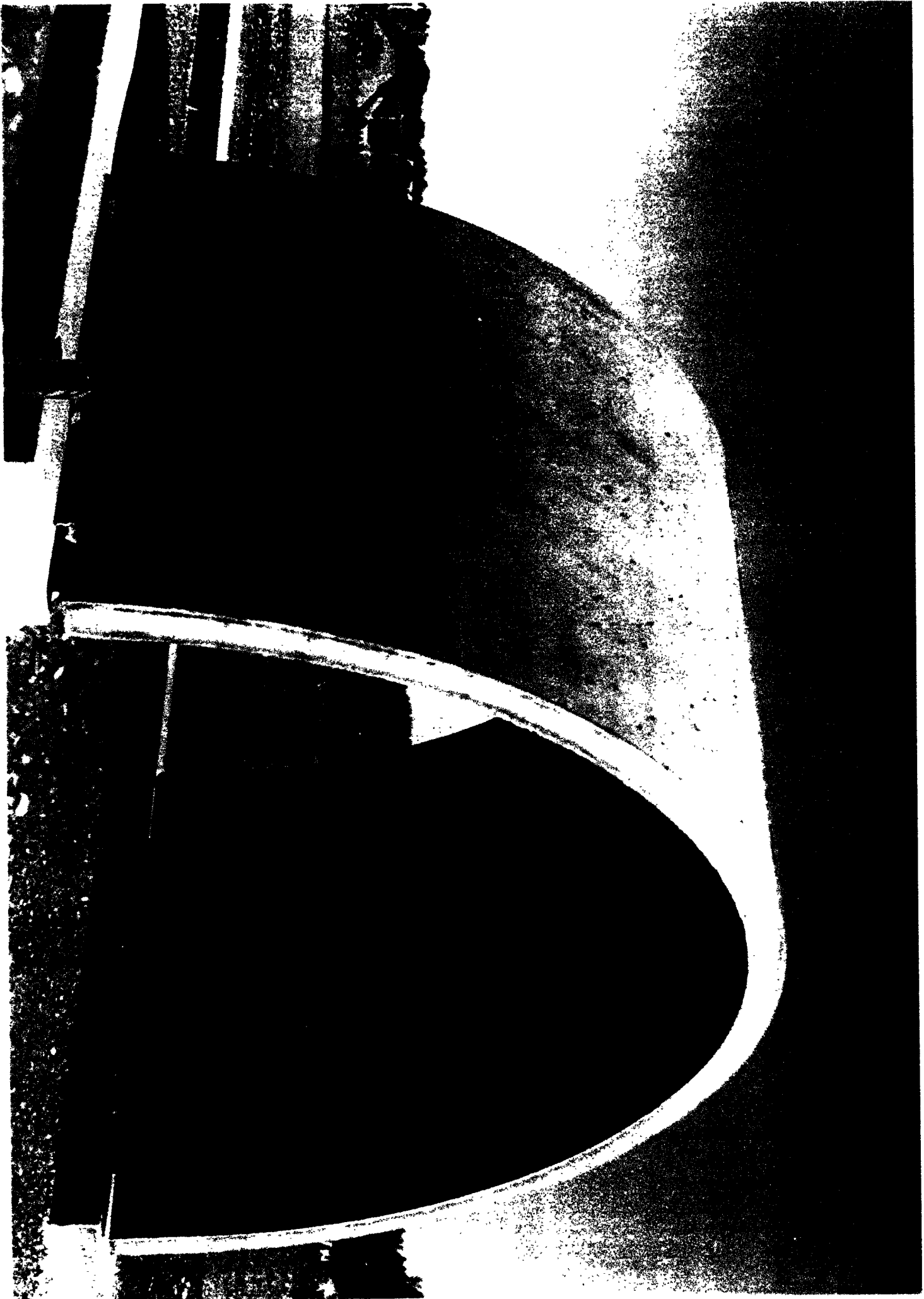
- ◆ Status:

- ACME manufacturing 17 enclosures/day
- Lavernier and ACME agreement to provide “just in time” delivery

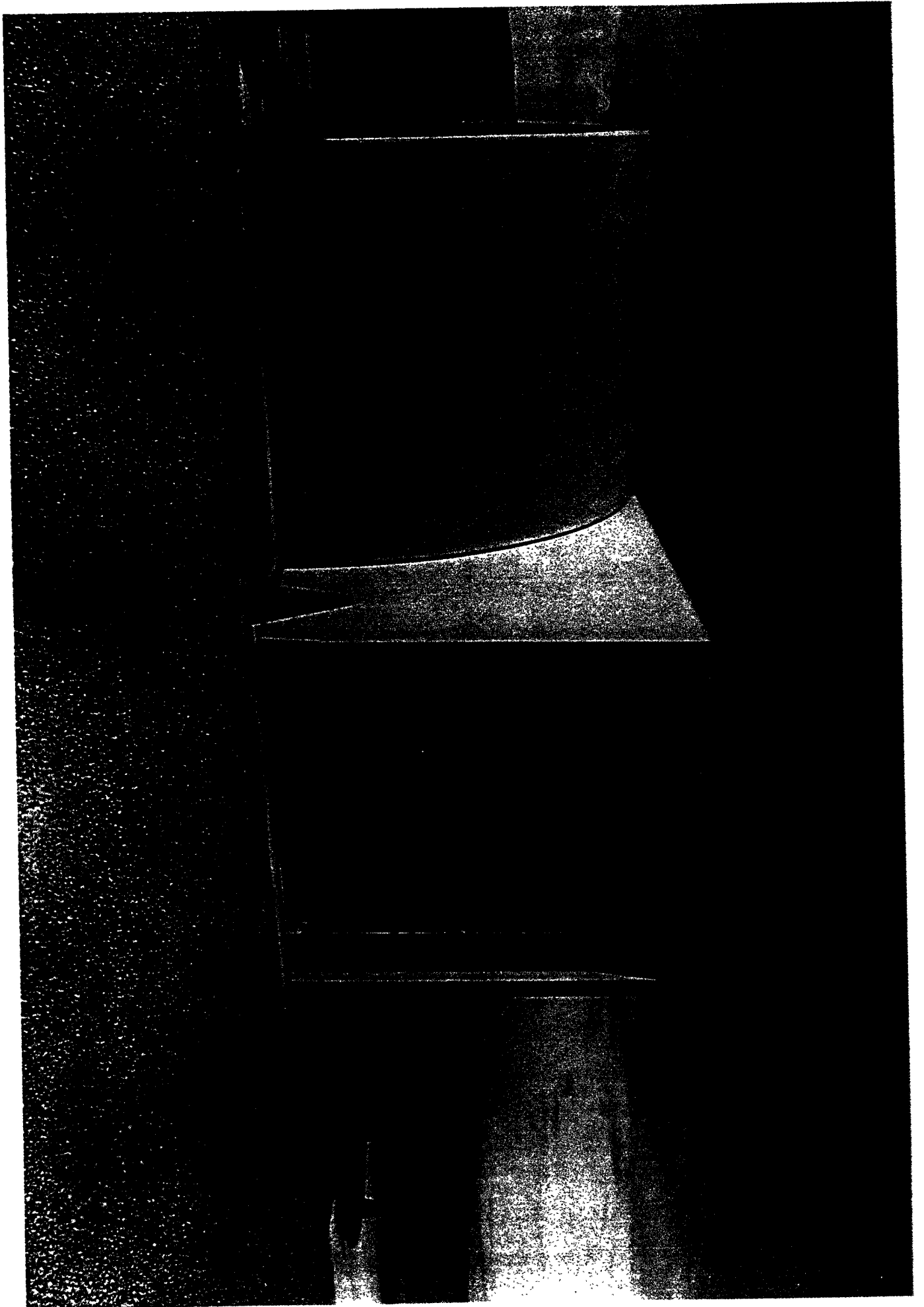
LIGO Facilities

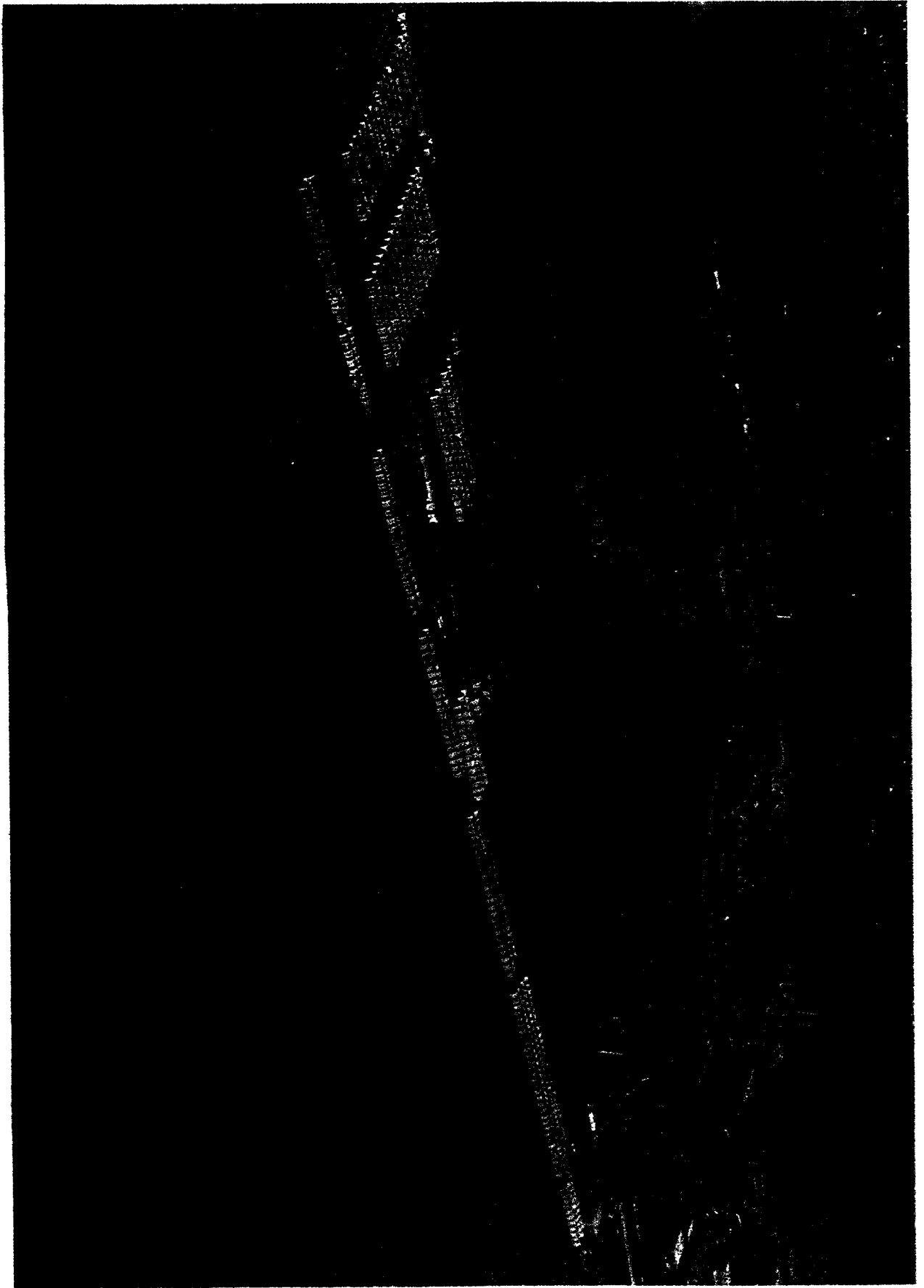
Beam Tube Enclosure







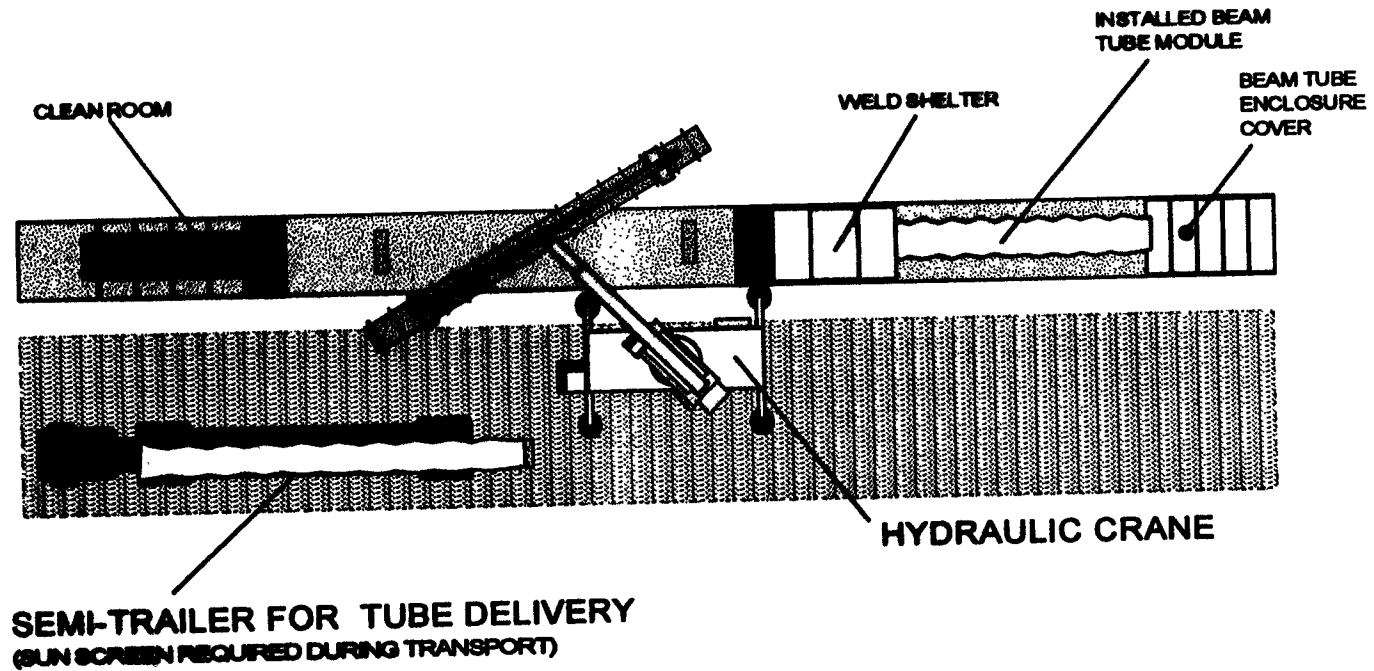






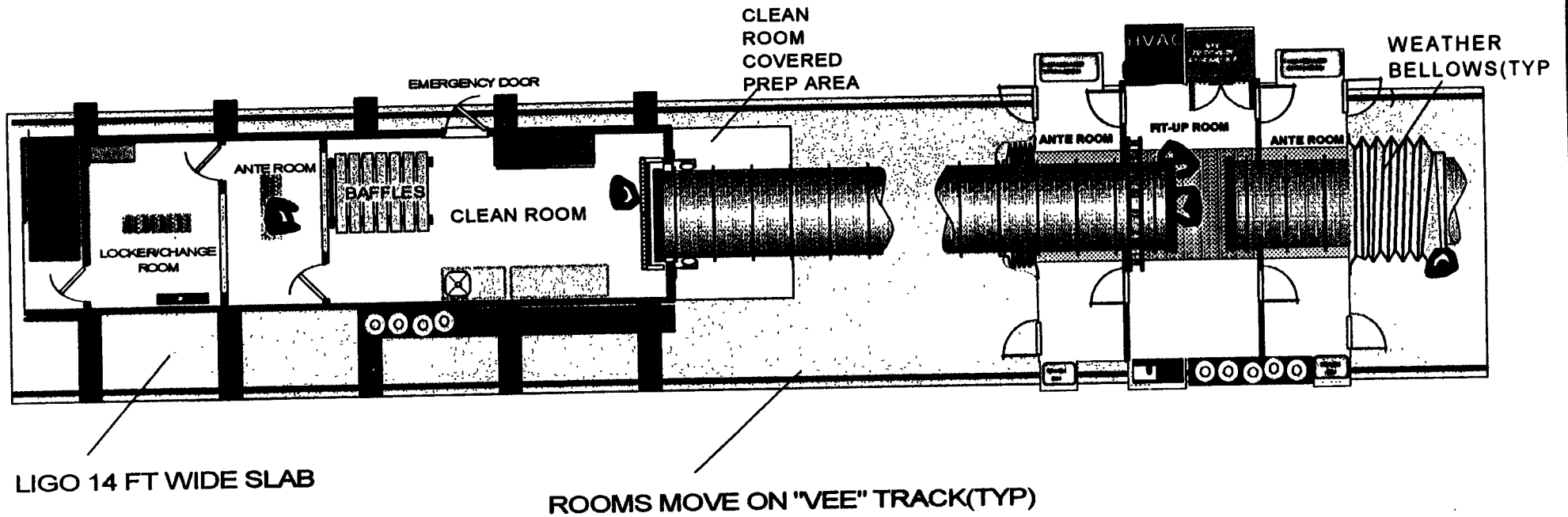
INSTALLATION WORK AREA - INSTALLING TUBES

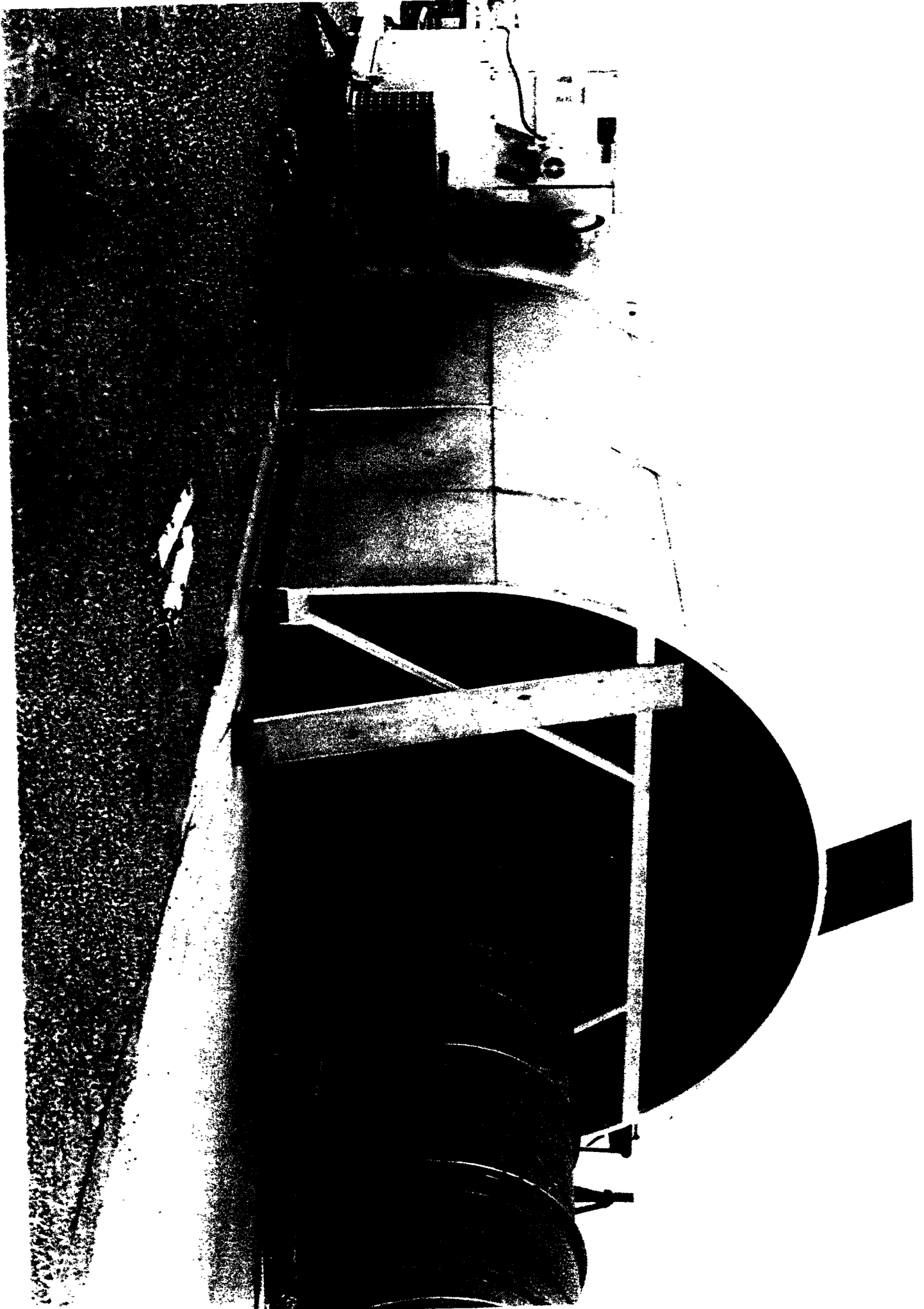
ATTACHEMENT "D"



PLAN VIEW AT TYPICAL TUBE LOCATION

INSTALLATION PLAN

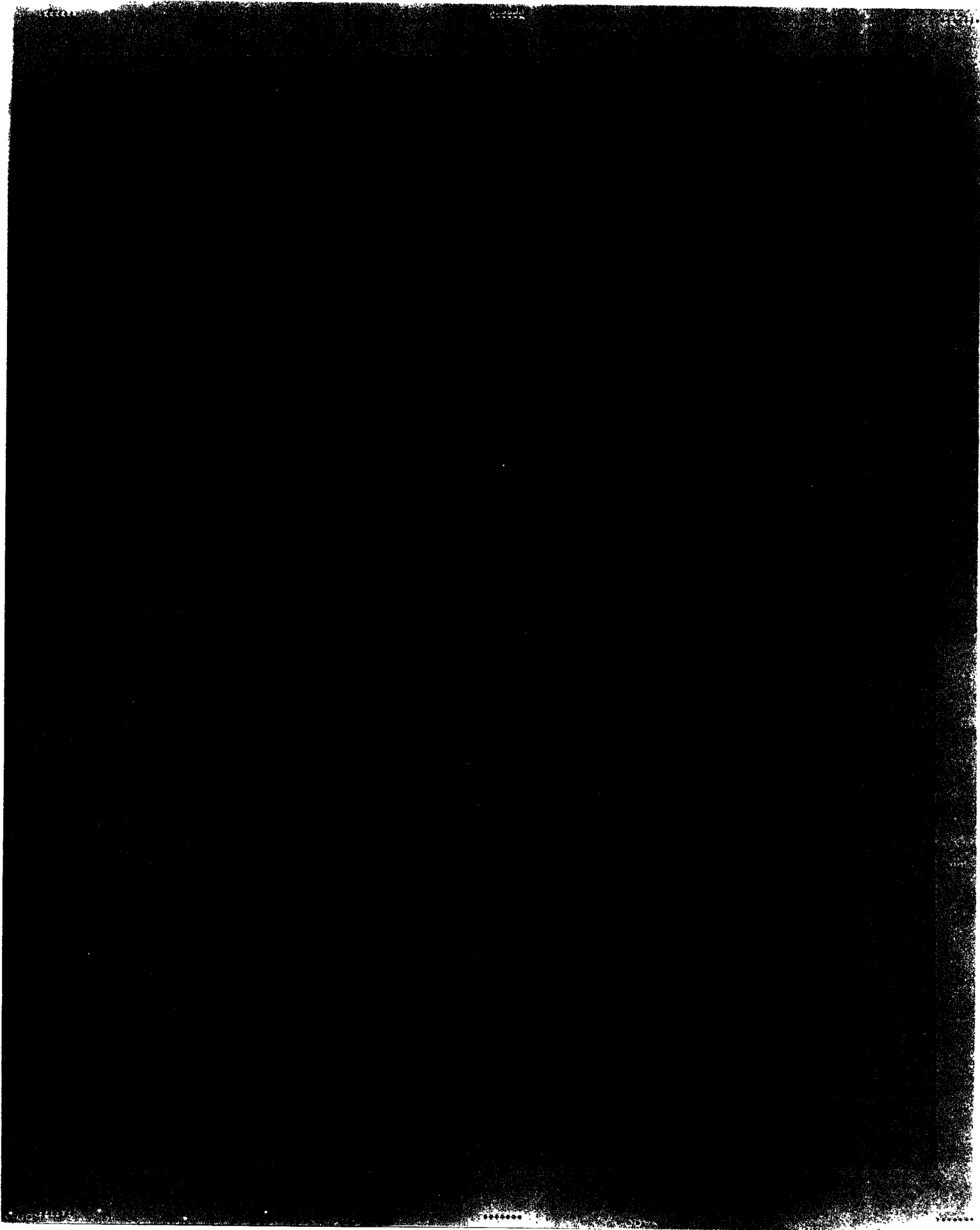


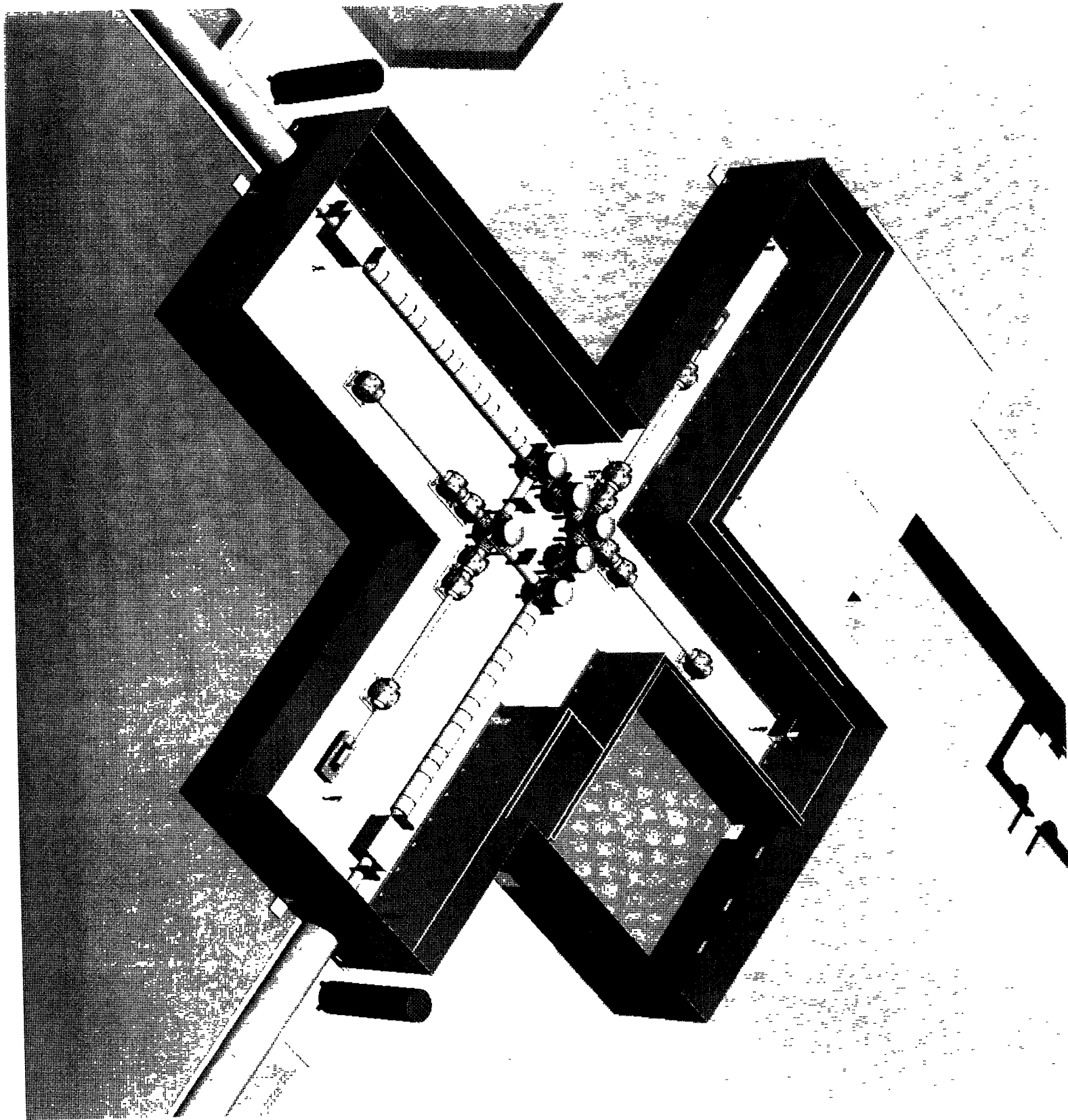


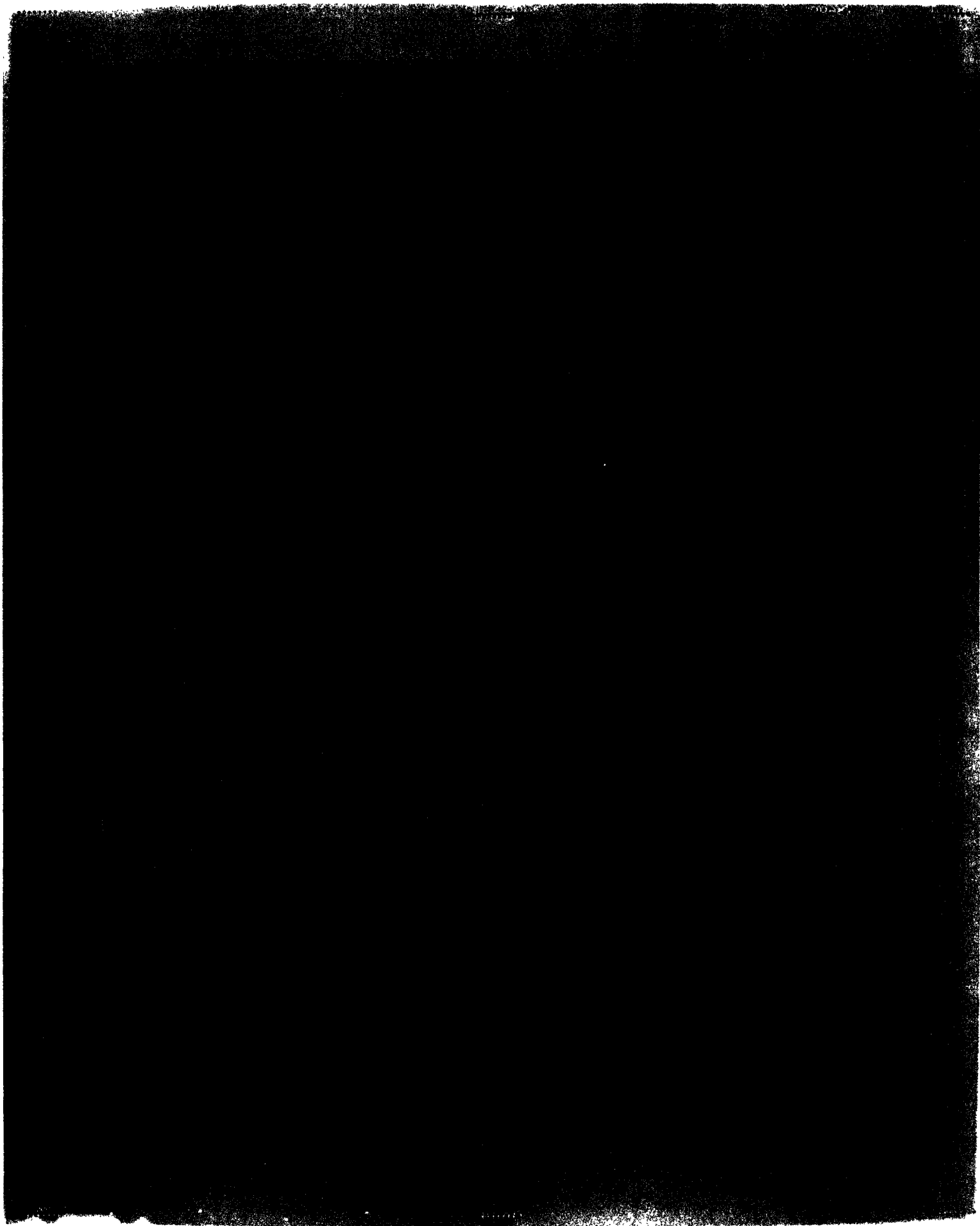
BT installation

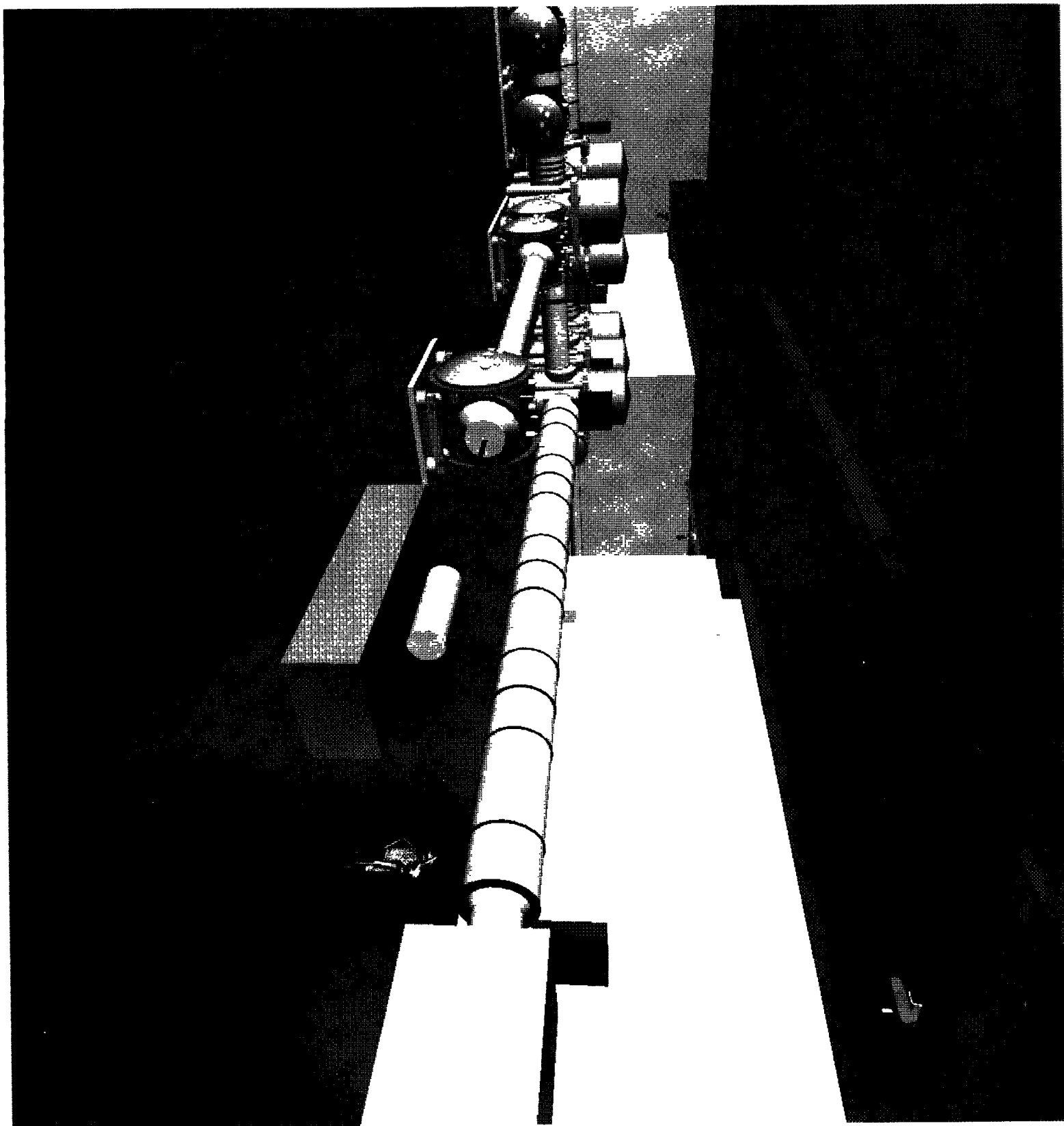
◆ Installation:

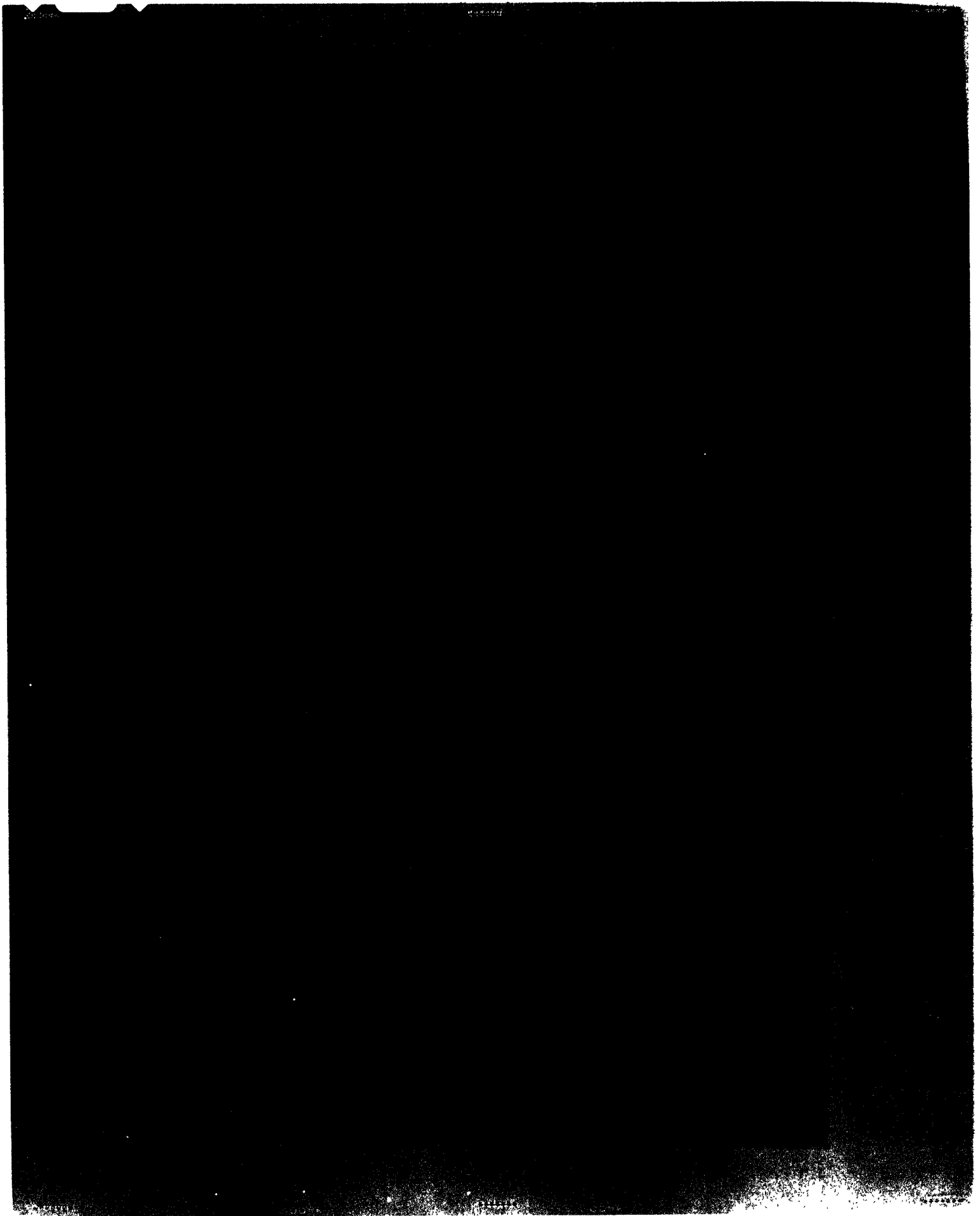
- » weld enclosures, air filtration system delivered to site
- » first gate valve installed
- » high precision site survey completed to provide reference locations for BT installation
- » installation readiness review completed

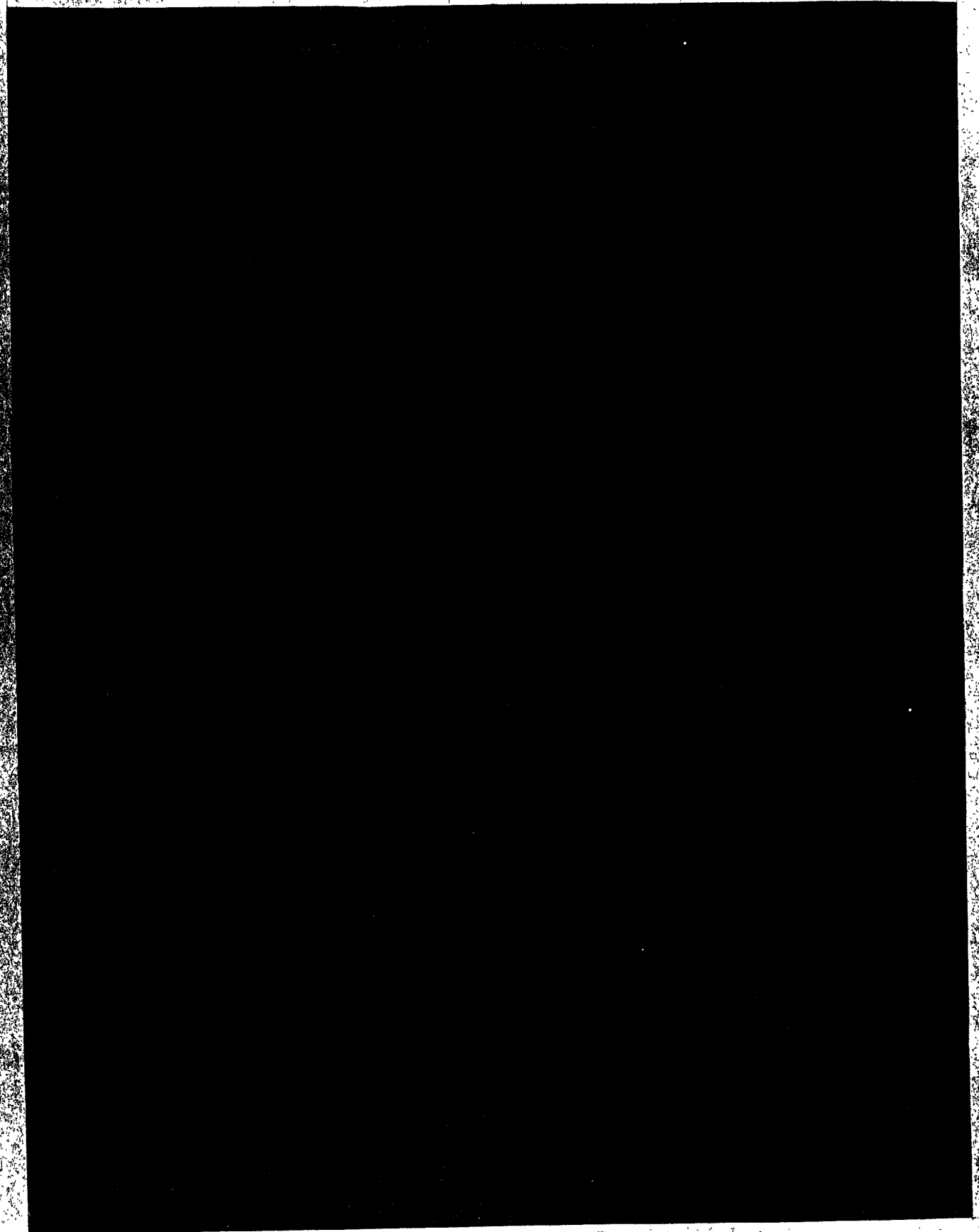


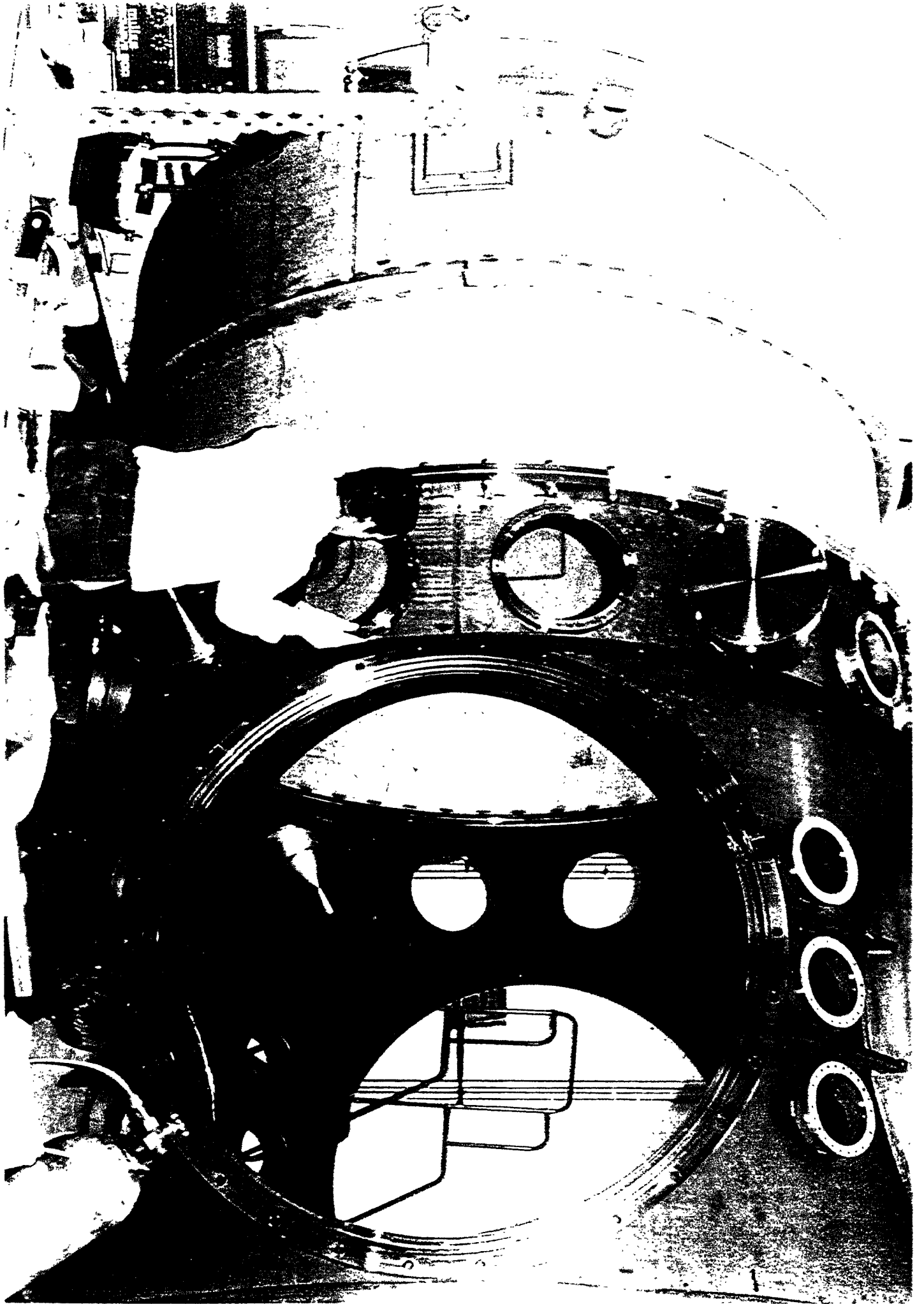


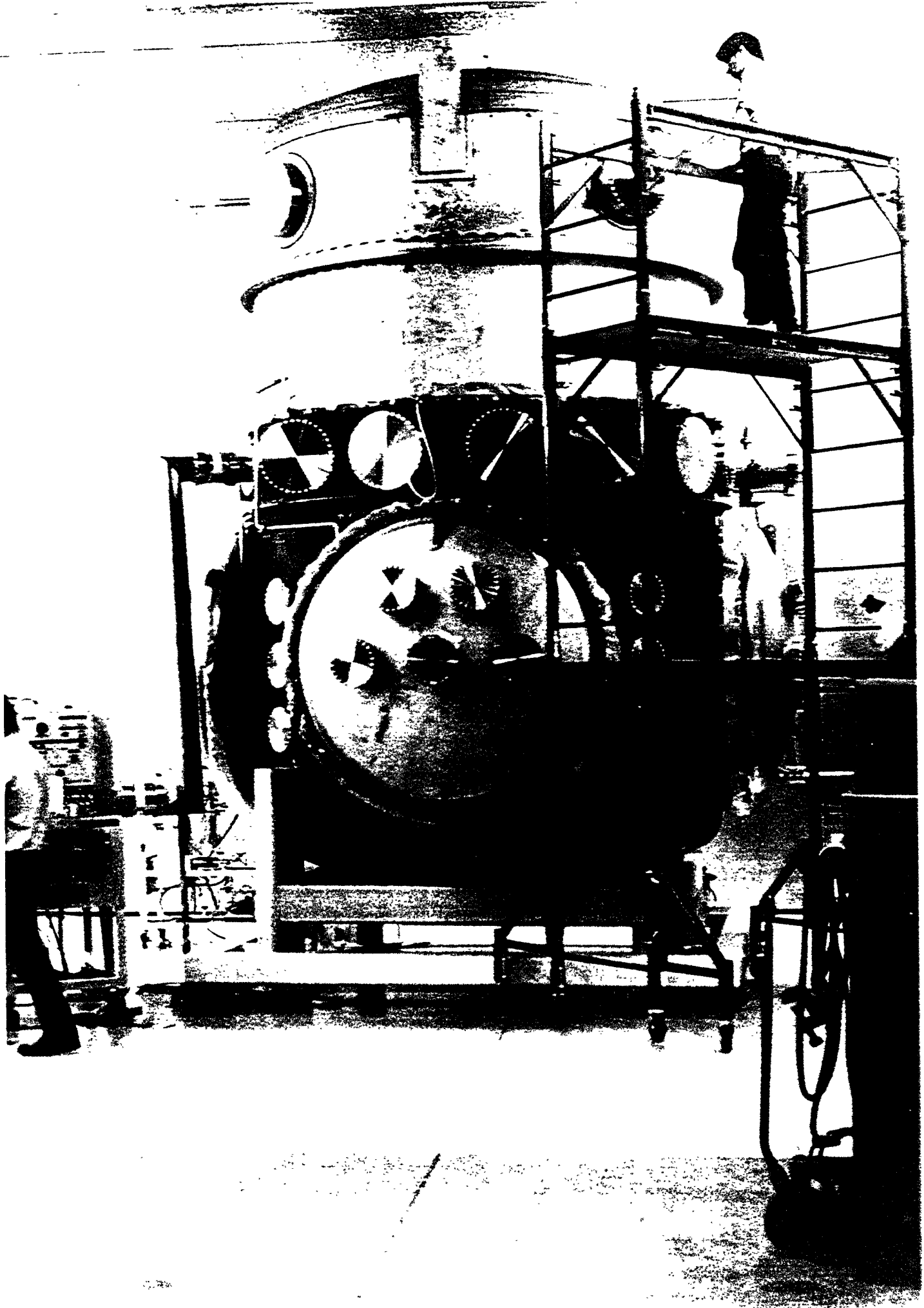












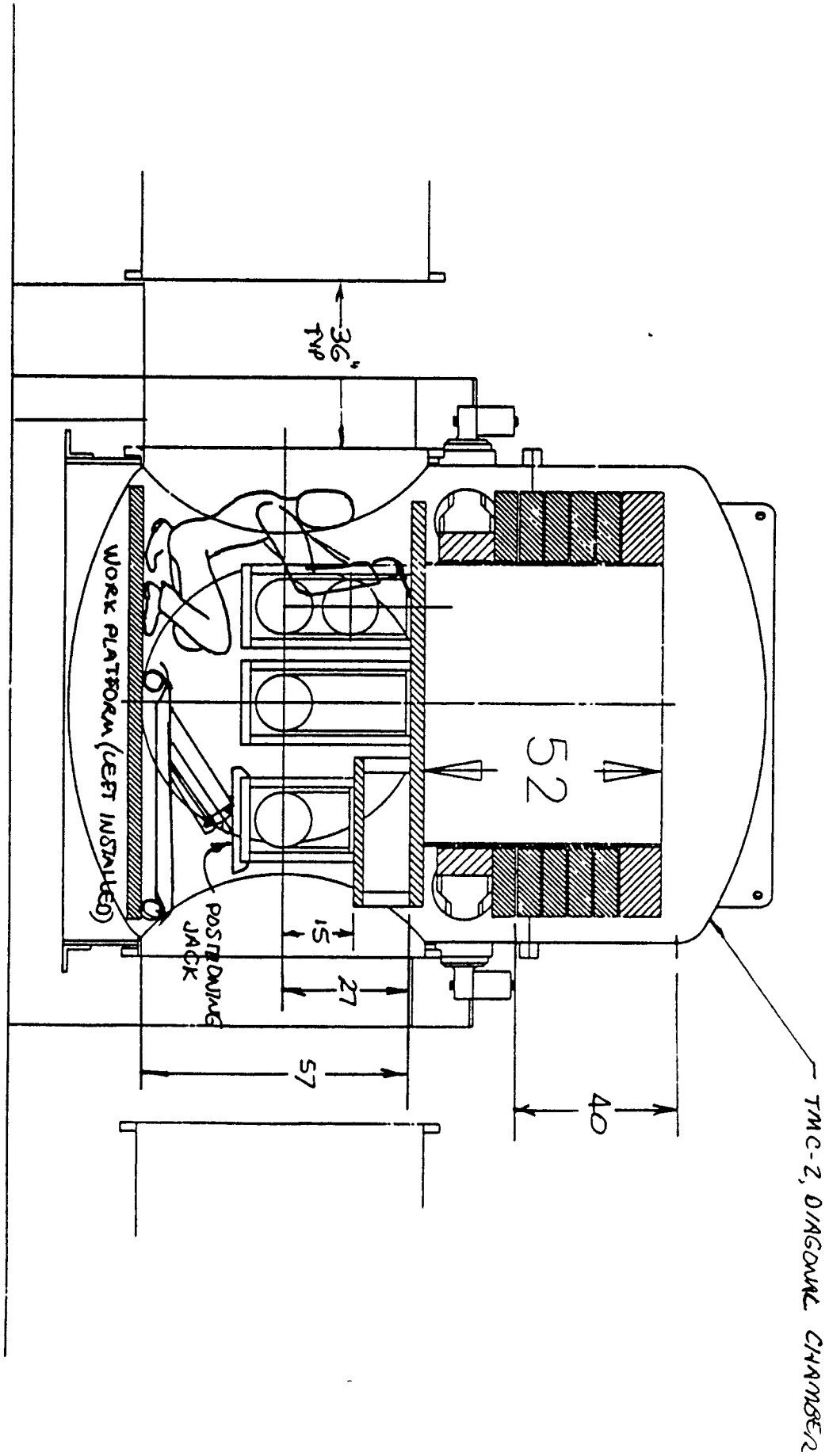
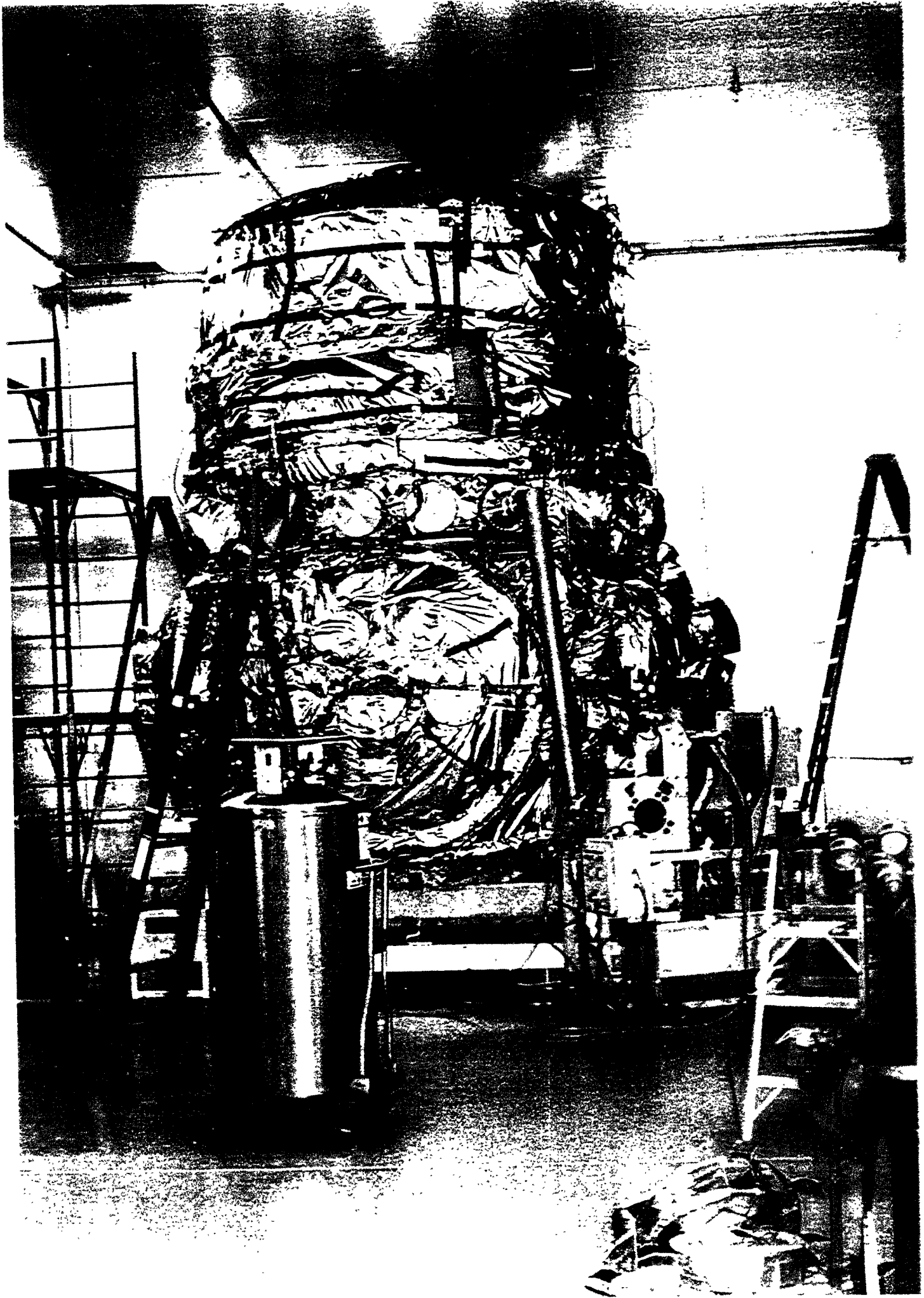
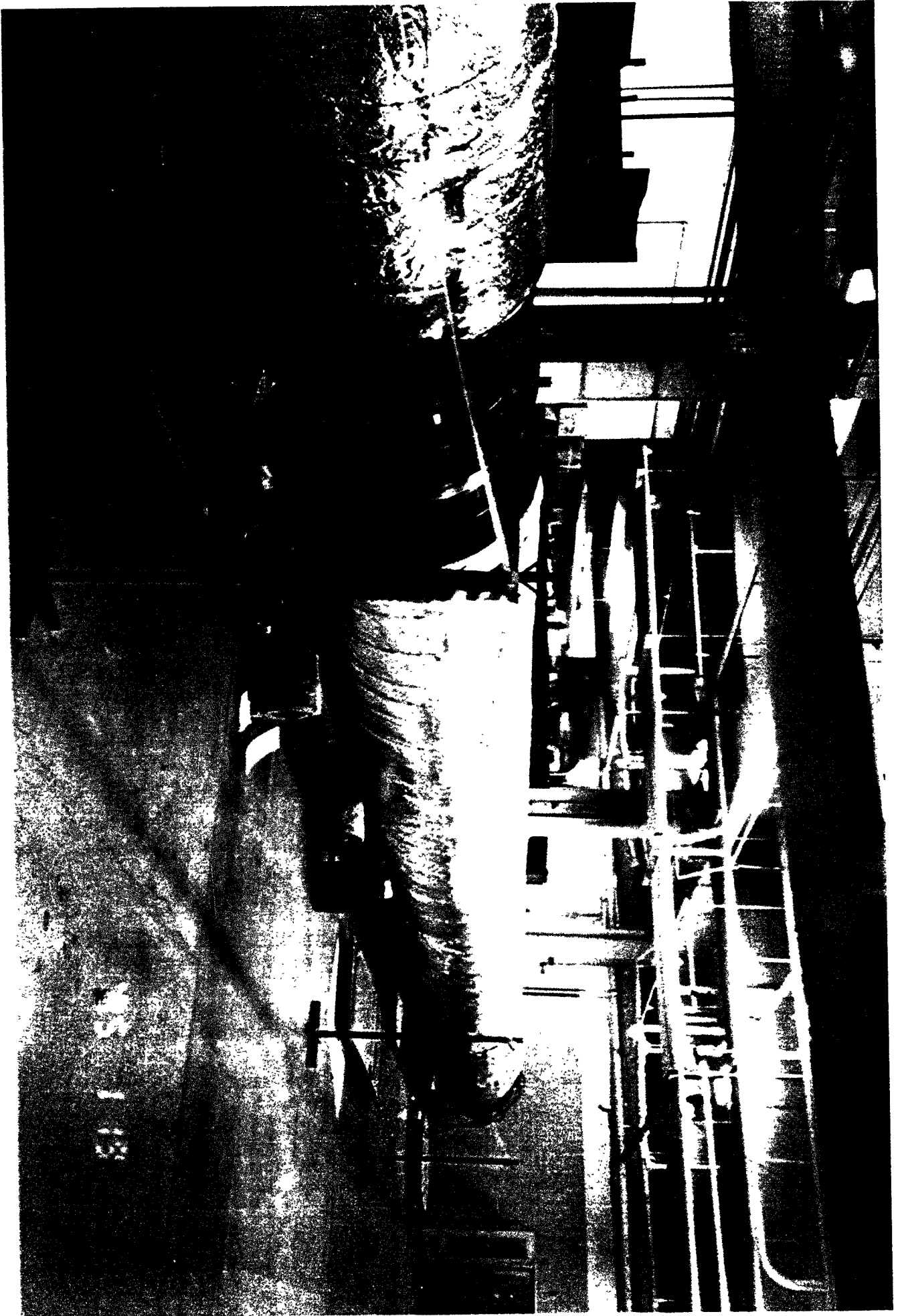


FIG. 3 INTERNAL ACCESS

9-2-92





425
113