



LBSC2

AUTHOR(S)	DATE	Document Change Notice, Release or Approval
Dennis Coyne, Calum Torrie, Eric James	27 Nov 2012	see LIGO DCC record Status

Instructions on the use of this document:

- 1) Use, and complete, this document on a cleanroom compatible computer while the work is proceeding. This procedure, and all of the applicable documents, must be available at all times during the procedure.
- 2) Use this procedure as a check list for preparation and during the installation; As each step is completed, enter the name of the person completing the work (or approving or checking the step), as well as the date and any comments or notes. In particular, note any discrepancies or deviations and augment with any missing definition. **ALL NOTES MUST BE RECORDED IN THE COMPLETED VERSION OF THIS DOCUMENT (NOT IN OTHER NOTEBOOKS OR FILES).** If the additional notes are too cumbersome to include within the body of this completed procedure, then electronically attach them to the completed procedure.
- 3) Once completed, file the document in the LIGO Document Control Center (DCC) as the next highest version of the procedure and add a note that this is a completed/finished procedure.
- 4) File any significant notes or data from the completed procedure in the electronic logbook (such as any deviations); as a minimum note in the electronic logbook that the installation was completed in accordance with this procedure (cite document number and revision).

Contents

- 1 Applicable Documents 2
- 2 SCOPE 4
 - 2.1 Major Assemblies 4
 - 2.2 Scope for the Initial Installation 7
- 3 REQUIRED EQUIPMENT LIST 7
- 4 PROCEDURE FOR CARTRIDGE ASSEMBLY 8
 - 4.1 Prerequisites for Cartridge Integration 8
 - 4.2 Install the BSC-ISI onto the Test Stand..... 9
 - 4.3 Perform final BSC-ISI testing/characterization prior to payload integration 9
 - 4.4 Install the Fiducial markers 10
 - 4.5 Attach the alignment template for the Beam Splitter (BS) suspension..... 10
 - 4.6 Weigh the full suspension payloads 10
 - 4.7 Install the balance masses onto the optics table..... 10
 - 4.8 Install the BS suspension..... 10
 - 4.9 Install BS Struts and Vibration Absorbers..... 11
 - 4.10 Rebalance the ISI Table..... 11
 - 4.11 Test the BS suspension 11
 - 4.12 Align the Optics..... 11
 - 4.13 Install the BS Elliptical Baffles 11
 - 4.14 Post-Integration, Cartridge Testing 11
- 5 PROCEDURE FOR INSTALLATION INTO THE CHAMBER 12
 - 5.1 Prerequisites for Chamber Installation 13
 - 5.2 Prepare the Chamber for Cartridge Installation..... 13
 - 5.3 Prepare the Cartridge Assembly for installation into the chamber 14
 - 5.4 Install the Cartridge Assembly into the Chamber..... 15

**LBSC2**

5.5	Align the Cartridge Assembly	16
5.6	Install the ITM Elliptical Baffles	16
5.7	Install the Optical Levers Periscope Assembly	16
5.8	Install the TCS Laser Projection System, In-Vacuum Steering Mirror Assembly	17
5.9	Clean the Optics	17
6	TESTING	18

1 Applicable Documents

All of the documents required for the installation of LBSC1 are listed below. Background and reference materials have been excluded to streamline the use of this installation procedure. Users may fill in the revision numbers of documents in the table.

Documents have been subdivided into the following categories, which are linked to this procedure in the DCC as “Related Documents”:

- [LIGO-D0900428: aLIGO Systems, LBSC2-L1 Top Level Chamber Assembly](#)
- [LIGO-D1201362: BSC Systems Level Supplementary Chamber-Level Build Documents](#)
- [LIGO-E1200900: aLIGO BSC Installation Procedures \(from sub-systems\)](#)
- [LIGO-E1200901: aLIGO BSC Safety Procedures \(associated with install\)](#)
- [LIGO-E1200902: aLIGO BSC Test Procedures \(associated with install\)](#)
- [LIGO-E1200903: aLIGO BSC Alignment Procedures \(associated with install\)](#)
- [LIGO-D1101674: aLIGO, SUS, BSC/HAM INSTALLATION TOOLING](#)

Table 1. LBSC1 Document List

LIGO-D0900428: [aLIGO Systems, LBSC2-L1 Top Level Chamber Assembly](#)

- LIGO-D0900429: [AdvLIGO VE BSC2-L1 Vacuum Equipment Assembly](#)
- LIGO-D1000513: [HEPI ASSEMBLY, BSC aLIGO](#)
- LIGO-D0900430: [AdvLIGO SEI BSC2-L1, XYZ Local CS for ISI Table](#)
- LIGO-D1101852: [AdvLIGO BSC2-L1 ISI Table, Payload & Suspended Mass Assembly](#)
- LIGO-D0900431: [AdvLIGO SUS BSC2-L1, XYZ Local CS for BS HR](#)
- LIGO-D0900525: [AdvLIGO SUS BSC2-L1, XYZ Local CS for Elliptical Baffle \(ITMX,ITMY\)](#)
- LIGO-D1200636: [AdvLIGO SUS, BSC2-L1 XYZ Local CS for CO2 Steering Mirror \(ITMX, ITMY\)](#)
- LIGO-D1003089: [Flange Layout – L1 Beam Splitter Chamber 2 \(BSC2\) BS](#)
- LIGO-D1200060: [CABLE HARNESS ROUTING CONFIGURATION, BSC-2](#)
- LIGO-D1101429: [ALIGO, BSC FLOORING ORIENTATION DETAILS](#)
- LIGO-D1200103: [aLIGO, SUS, OPTIC TABLE .38-16 BSC2-L1/BSC4-H2 FIDUCIAL KIT](#)
- LIGO-E1101164: [BSC2-L Top Level Chamber Assembly BOM](#)

LIGO-D1201362: [BSC Systems Level Supplementary Chamber-Level Build Documents](#)

- LIGO-E1000337: [AdvLIGO Detailed Mass Properties-CG Report BSC Tables \(LLO\)](#)
- LIGO-D1002124: [Stand, Test, BSC-ISI+Quad + HAM-ISI, aLIGO](#)
- LIGO-D1101271: [ALIGO BSC ISI OPTICAL TABLE HOLE TABULATION](#)

**LBSC2**

- LIGO-D1101775: [aLIGO, ELECTRICAL FEEDTHROUGH TYPES, TYPICAL SUBFLANGES, AND PORT CONFIGURATIONS](#)
- LIGO-D1100430: [BSC CABLE TRAY ASSEMBLY](#)
- LIGO-D1101050: [ALIGO, SUS ALIGNMENT TEMPLATE ASSY.](#)
- LIGO-D1003140: [Lifting Bar, 3 Point, BSC Cartridge, aLIGO](#)
- LIGO-D1000744: [Lift Hook Receiver, aLIGO BSC ISI](#)
- LIGO-D1001990: [Platform Walkway, BSC Installation](#)
- LIGO-D1002926: [Module-E, BSC Cartridge installation, aLIGO](#)
- LIGO-D1002410: [Walking Plates, BSC Chamber, Top, aLIGO](#)
- LIGO-T1100292: [Viewport Source List](#)
- LIGO-T1000746: [Viewports Subsystem Final Design Document](#)
- LIGO-G1000125: [aLIGO BSC-ISI, HAM-ISI, and HEPI Basis and Naming Conventions](#)
- LIGO-D1000392: [aLIGO BS/FM MAIN ASSEMBLY](#)

LIGO-E1200900: [aLIGO BSC Installation Procedures \(from sub-systems\)](#)

- LIGO-E1200344: [All BSC, Install Completed Cartridge Into Chamber Procedure, aLIGO](#)
- LIGO-E1200322: [BSC2-L1 Requirements and Procedure, Cartridge Flight and Insertion into BSC Chambers, aLIGO](#)
- LIGO-E040011: [Installation Specification - HEPI Assembly and Installation Procedures](#)
- LIGO-E1101162: [BSC Dome Removal Procedure](#)
- LIGO-M1100068: [LHO BSC Door Removal and Installation Procedure](#)
- LIGO-E1101051: [ALIGO BSC Work Platform Assembly Instructions](#)
- LIGO-T1100174: [Weighing ALL assemblies that are mounted to a HAM isolation table, BSC isolation table or a BSC stage 0](#)
- LIGO-T1100489: [BS/FM installation lock-down procedure](#)
- LIGO-M990173: [Conflat Flange Assembly Procedure](#)
- LIGO-E1100484: [Assembly Specification for the aLIGO, High Quality, Viewports](#)
- LIGO-E000121: [Hanford Checklist - Spool Removal](#)
- LIGO-M1000360: [LLO Vent Isolatable Volumes Procedure](#)
- LIGO-M990180: [LLO Large GNB Valve Operating Procedures](#)
- LIGO-E1000079: [First Contact Procedure](#)
- LIGO-E1100439: [General Optics Cleaning Procedure](#)
- LIGO-T1200321: [Guidelines on protecting the Cavity Optics in chamber wrt First Contact](#)
- LIGO-T1200198: [First Contact Application Layer Scenarios](#)

LIGO-E1200901: [aLIGO BSC Safety Procedures \(associated with install\)](#)

- LIGO-E1200925: [BSC Cartridge Installation Hazard Analysis, aLIGO](#)
- LIGO-E1100814: [Cartridge Assembly Hazard Analysis](#)
- LIGO-E1000252: [BSC Installation Repair arm and HAM Installation arm Hazard Analysis](#)
- LIGO-E1101017: [Cartridge Lifting Hardware, Loading Analysis](#)
- LIGO-E1200328: [Critical Lift Plan for the aLIGO BSC2-L1 Cartridge Installation](#)
- LIGO-E1200327: [BSC2-L1 Cartridge Installation Hazard Analysis](#)

LIGO-E1200902: [aLIGO BSC Test Procedures \(associated with install\)](#)

- LIGO-M1000211: [Subsystem-Level and System-Level Testing Requirements](#)
- LIGO-E1000486: [aLIGO BSC-ISI Testing Procedure, Phase I: Assembly Validation](#)



LBSC2

- LIGO-E1000487: [aLIGO BSC-ISI Testing Procedure, Phase II : Integration process](#)
- LIGO-E1000488: [aLIGO BSC-ISI Testing Procedure, Phase III: Control Commissioning](#)
- LIGO-G1200070: [Ideal Order/Contents of aLIGO Triple SUS Testing / Commissioning](#)

LIGO-E1200903: [aLIGO BSC Alignment Procedures \(associated with install\)](#)

- LIGO-E1200392: [Initial Alignment Procedure LBSC2](#)
- LIGO-D1200905: [Alignment Monument Layout, LLO Corner Station, BSC Mechanical Test Stands](#)

LIGO-D1101674: [aLIGO, SUS, BSC/HAM INSTALLATION TOOLING](#)

- LIGO-E1101131: [BSC Test Stand, Quad, TMS, Tooling clearances](#)
- LIGO-D1001730: [Sketch of Test Stand with respect to the FMP cartridge tooling](#)
- LIGO-E1100520: [Key safety information associated with the FMP supplied Genie's, lifts and carts](#)
- LIGO-D1100886: [MODIFIED GENIE LIFT FORKS](#)
- LIGO-E1100832: [BSC Repair Arm User Guide](#)
- LIGO-D1200482: [aLIGO Spreader Bar, HAM / BSC Repair Arm](#)

2 SCOPE

The scope of this procedure is installation of interferometer components and assemblies in the LBSC2 chamber (see Figure 1) below.

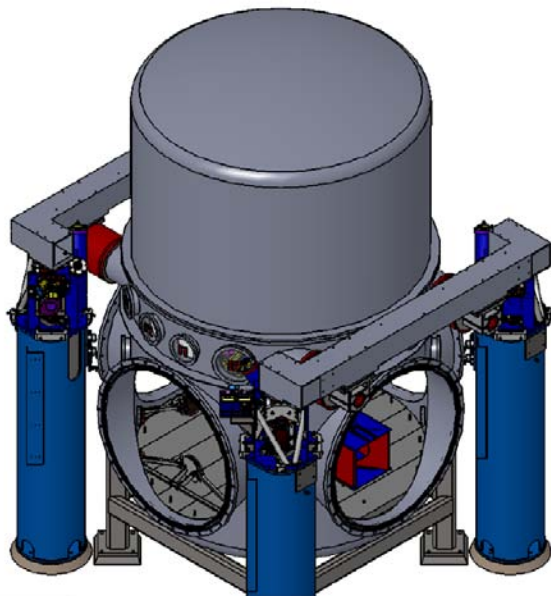

a) with vacuum equipment, HEPI

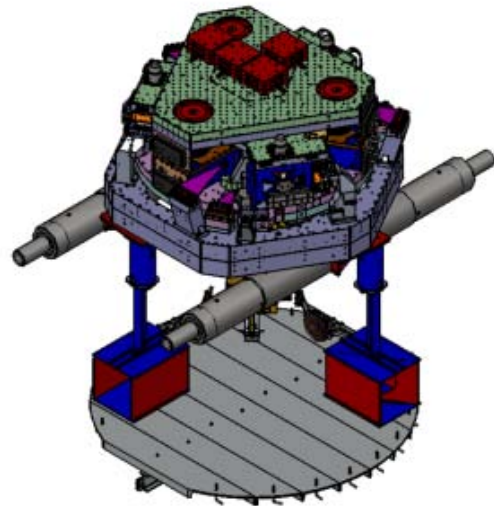

b) without vacuum equipment, HEPI

Figure 1 LBSC2 Chamber Installation

2.1 Major Assemblies

This installation includes the following principal, sub-system major assemblies:



LASER INTERFEROMETER GRAVITATIONAL WAVE OBSERVATORY
ALIGO INSTALLATION PROCEDURE

E1200329 -v3-
Document No Rev.
Sheet 5 of 18

LBSC2

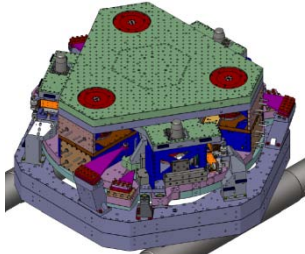
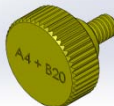
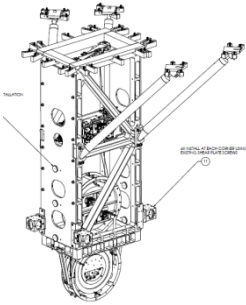
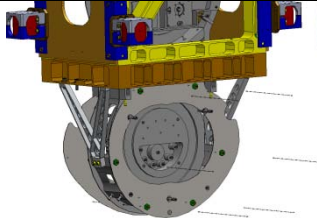
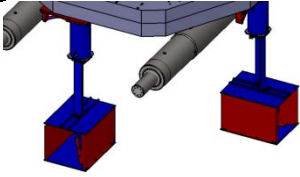
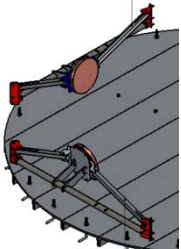
Subsys.	Assy Dwg	Sub-Assembly Name	Image
SEI	D0900430	BSC-ISI assembly Includes: aLIGO BSC ISI Assembly (D0901182)	
SYS	D1200103	Optic Table 3/8-16 BSC2-L1/BSC4-H2 Fiducial Kit	
SUS	D0900431	L1 BS triple suspension assembly including: BS/FM Top Level Assembly (D1000392) Vibration Absorbers (D100424) Optics Cap (D1100864)	
AOS/SLC	D1200750	BS Elliptical Baffles	
AOS/SLC	D0900525	ITM Elliptical Baffle Assemblies Includes: ITM Elliptical Baffle Assembly (D1003238) - 2 required.	
AOS/TCS	D1101851	TCS CO ₂ Laser In-Vacuum Steering Optics Assy, L1-BSC2	



LASER INTERFEROMETER GRAVITATIONAL WAVE OBSERVATORY
ALIGO INSTALLATION PROCEDURE

E1200329 -v3-
 Document No Rev.
 Sheet 6 of 18

LBSC2

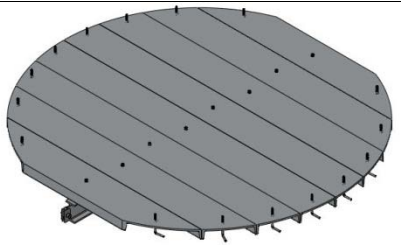
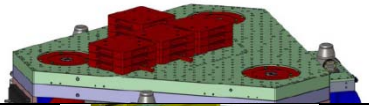
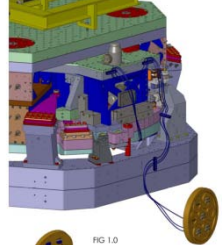
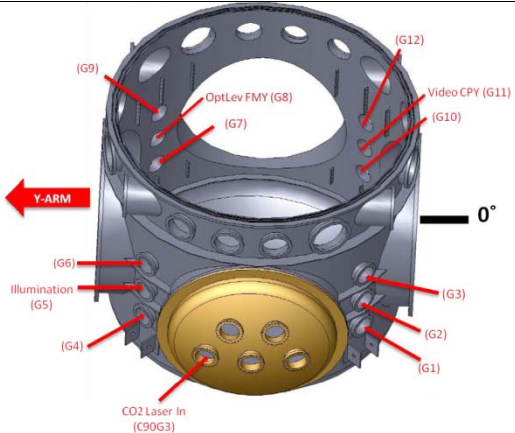
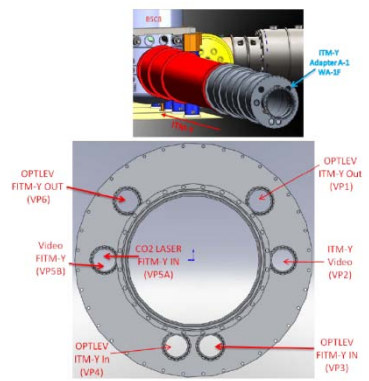
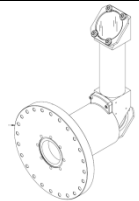
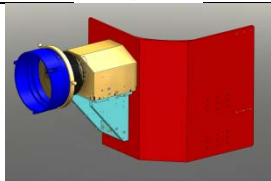
FMP	D961115	BSC Floor Assy																															
SYS	D1101852	BSC2-L1 ISI Table Balance Masses																															
SEI/SYS	D1003089 D1200060 D1101775	Flange Layout - L1 BSC-2 Cable Harness Routing Configuration, BSC-2 Electrical Feedthrough Types																															
AOS/SLC	T1100292 Viewport Source List																																
<table border="1" style="width: 100%; border-collapse: collapse;"> <thead> <tr> <th>IFO</th> <th>CHAMBER</th> <th>VIEWPORT</th> <th>FUNCTION</th> <th>DESCRIPTION</th> <th>VIEWPORT P/N</th> <th>SOURCE</th> </tr> </thead> <tbody> <tr> <td>L1</td> <td>BSC2</td> <td>G2</td> <td>OPTLEV</td> <td>BS-IN/OUT</td> <td>2.7 DIA, MDC450004-AR635</td> <td>CATALOG</td> </tr> <tr> <td>L1</td> <td>BSC2</td> <td>G8</td> <td>VIDEO</td> <td>BS</td> <td>5.4 DIA VP800/450009</td> <td>CATALOG</td> </tr> <tr> <td>L1</td> <td>BSC2</td> <td>G9</td> <td>ILLUMINATION</td> <td></td> <td>5.4 DIA VP800/450009</td> <td>iLIGO</td> </tr> </tbody> </table>						IFO	CHAMBER	VIEWPORT	FUNCTION	DESCRIPTION	VIEWPORT P/N	SOURCE	L1	BSC2	G2	OPTLEV	BS-IN/OUT	2.7 DIA, MDC450004-AR635	CATALOG	L1	BSC2	G8	VIDEO	BS	5.4 DIA VP800/450009	CATALOG	L1	BSC2	G9	ILLUMINATION		5.4 DIA VP800/450009	iLIGO
IFO	CHAMBER	VIEWPORT	FUNCTION	DESCRIPTION	VIEWPORT P/N	SOURCE																											
L1	BSC2	G2	OPTLEV	BS-IN/OUT	2.7 DIA, MDC450004-AR635	CATALOG																											
L1	BSC2	G8	VIDEO	BS	5.4 DIA VP800/450009	CATALOG																											
L1	BSC2	G9	ILLUMINATION		5.4 DIA VP800/450009	iLIGO																											
AOS/ OptLev	D1100625-BSC2L1	BS OpLev Periscope Assy																															
AOS/ OptLev	D1200640	BS OptLev Transceiver Assy (on pier)																															

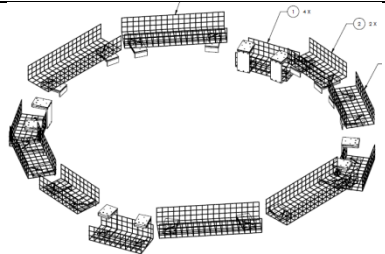
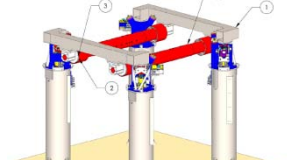
Cable tray	D1100430	BSC Cable Tray Overall Assy <i>needs revision to as-built (as being built) design</i>	
HEPI	D1000513	HEPI Assembly, BSC aLIGO	

This procedure starts with the integration of the payload elements of the LBSC2 chamber in the “cartridge assembly” on the BSC Mechanical Test Stand (D1002124) and then proceeds to the integration of the cartridge assembly within the LBSC2 chamber. The “cartridge assembly” is comprised of the BSC-ISI system with as many of the payload elements integrated onto the optics table and the stage 0 structure of the BSC-ISI as possible. The cartridge assembly is integrated and aligned while on the BSC mechanical test stand. The cartridge is then lifted, flown to the chamber and lowered into position onto the BSC support tubes. Those elements which could not be integrated on the test stand are added in situ and the entire cartridge, and optical elements, then aligned in situ.

2.2 Scope for the Initial Installation

For LBSC2, the two elliptical baffles that eventually will attach to the ESI stage 0 cannot be installed onto the cartridge while it is on the test stand. They will be installed after the cartridge is installed into the chamber.

3 REQUIRED EQUIPMENT LIST

Each of the procedures referenced within this overall procedure call out required equipment and parts/assemblies. Below is listed only those parts or assemblies not covered in the subsidiary procedures.

- See the Bill Of Materials (BOM) for the LBSC2 assembly listed in the Document Control Center (DCC) entry for [D0900428: AdvLIGO Systems, BSC2-L1 Top Level Chamber Assembly](#)
- Genie lift for transport of the BS SUS to the test stand
- For custom assembly/installation tooling, see [D1101674](#) which covers various usages of the tooling.
 - Sheet 7 is configuration used for the BS upper structure.
 - Sheet 7 is configuration used for the BS lower structure

LBSC2

completed, approved or checked by:

date:

comments (optional):

4 PROCEDURE FOR CARTRIDGE ASSEMBLY

The LBSC2 cartridge assembly is depicted in Figure 2. The major optics assembly integrated into the LBSC2 cartridge is the Beam Splitter (BS) suspension assembly ([D0900431](#)). The two elliptical baffles are not part of the cartridge assembly as they interfere with the test stand.

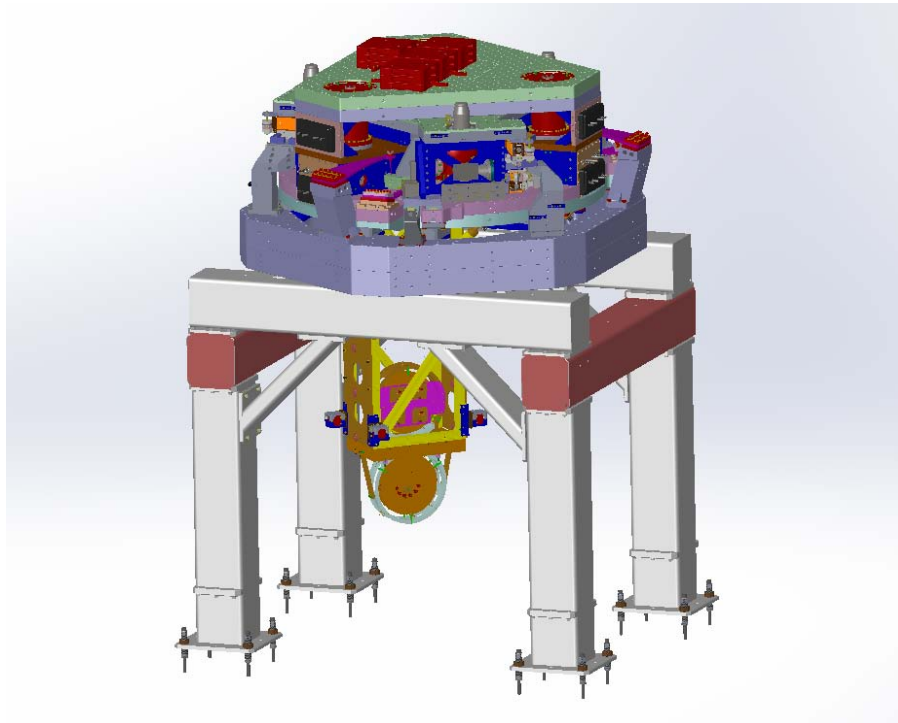

Figure 2: The LBSC2 cartridge assembly on the BSC Mechanical Test Stand (D1002124)

N.B.: The configuration "full cartridge" of [D0900428](#), SolidWorks PDMW vault version X-106 is shown, modified to exclude the Elliptical Baffles ([D0900525](#)) since the baffles interfere with the test stand.

4.1 Prerequisites for Cartridge Integration

- The BSC mechanical test stand must be set so that the interface plane with the BSC-
ISI stage 0 is horizontal.

LBSC2

- The features of the BSC mechanical test stand which interface to the BSC-ISI platform shall be used to establish a centerline and two offset lines with alignment monuments/references in the floor, as depicted in the [D1101596](#).
- An appropriate clean room should be installed over the test stand. For this procedure we are using BSC Test Stand #1.

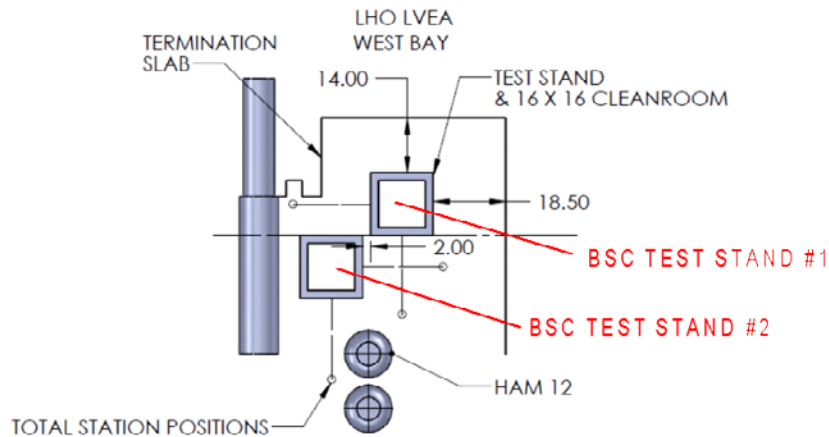

note that this illustration is for LHO but is similar to LLO.

- All payload assemblies must be acceptance tested (to the extent possible and planned) prior to integration into the cartridge assembly.

completed, approved or checked by:

date:

comments (optional):

4.2 Install the BSC-ISI onto the Test Stand

Using D1000744—Lift Hook Receiver assembly

- The BSC-ISI must be oriented in the same direction as it will be in chamber LBSC2 (as defined in [G1000125](#)).
- Remove the [D1000744](#): Lift Hook Receiver assembly.

completed, approved or checked by:

date:

comments (optional):

4.3 Perform final BSC-ISI testing/characterization prior to payload integration



LBSC2

completed, approved or checked by:
date:
comments (optional):

4.4 Install the Fiducial markers

- Install the Fiducial Kit ([D1200103](#)) onto the ISI in their designated positions. Use [D1101271](#) as a guide.

4.5 Attach the alignment template for the Beam Splitter (BS) suspension

- Attach one alignment template per suspension structure in accordance with [D0900431](#), sheet 3:. The hole numbering system is defined in [D1101271](#): aLIGO BSC ISI Optical Table Hole Tabulation.

completed, approved or checked by:
date:
comments (optional):

4.6 Weigh the full suspension payloads

- Weigh the full BS suspension, record below
- Systems to confirm, or revise, the mass balancing plan/drawing ([D1101852](#)).

Payload	Mass (Kg)	Comments/caveats
BS Suspension		

completed, approved or checked by:
date:
comments (optional):

4.7 Install the balance masses onto the optics table

- Install the balance masses in accordance with [D1101852](#): [AdvLIGO BSC2-L1 ISI Table, Payload & Suspended Mass Assembly](#)

4.8 Install the BS suspension

- Check Dog clamps are installed and tightened as per E1100405, remove TFE stops.
- Suspend BS as per [T1100489](#).
- Cable as per [???](#). *Need correct document number.*

**LBSC2**

- Set BOSEMs, accounting for buoyancy

completed, approved or checked by:
date:
comments (optional):

4.9 Install BS Struts and Vibration Absorbers

- Install per [D0900431](#)

4.10 Rebalance the ISI Table**4.11 Test the BS suspension****4.12 Align the Optics**

- Align the optical elements on the cartridge in accordance with [E1200392](#): Initial Alignment Procedure - LBSC2

completed, approved or checked by:
date:
comments (optional):

4.13 Install the BS Elliptical Baffles

- Note: installation of the BS Elliptical Baffles is done after the BS suspension assembly has been aligned in the previous step.
- Install the BS Elliptical Baffles per **XXX**.
- Align the Elliptical Baffles using the same alignment setups and procedures as the ones used to align the BS.

4.14 Post-Integration, Cartridge Testing

Testing of each of the major, actively controlled, assembly must be performed after integration into the Cartridge Assembly and prior to installation into the Chamber (i.e. Phase II testing per [M1000211](#)):

- [E1000487](#), “BSC-ISI Testing Procedure, Phase II : Integration process”
- [E1000496](#), “SUS BS/FM Testing and Commissioning Documentation” (*this should be a pointer to the specific phase 2 test procedure(s) and not this top level link*)



LBSC2

5 PROCEDURE FOR INSTALLATION INTO THE CHAMBER

The completed installation of all of the interferometer assemblies and components associated with the LBSC2 chamber is depicted in Figure 3 and Figure 4.

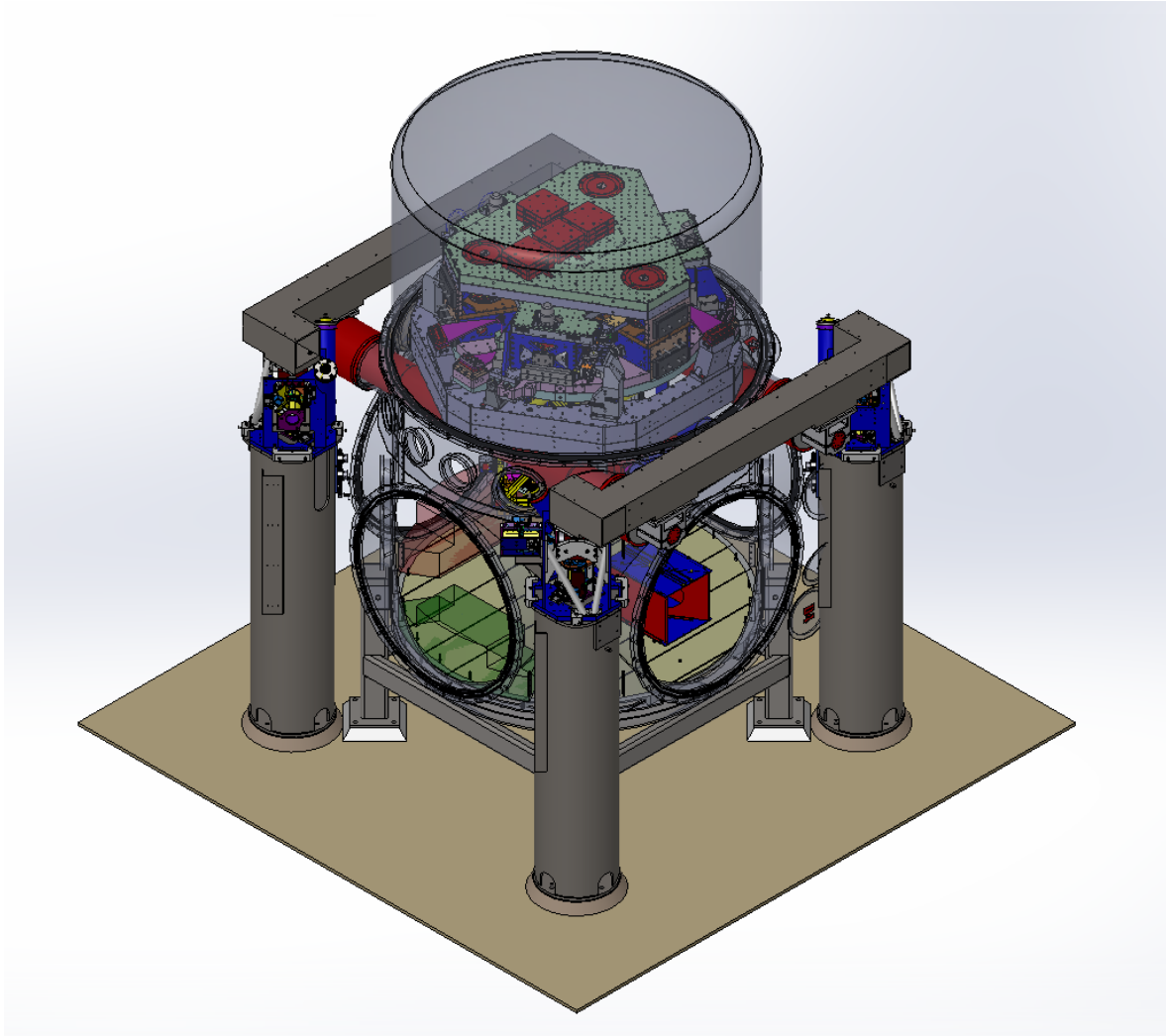

Figure 3: Image of LBSC2 installation (from SolidWorks assembly model for D0900428, with chamber transparent for clarity)

LBSC2

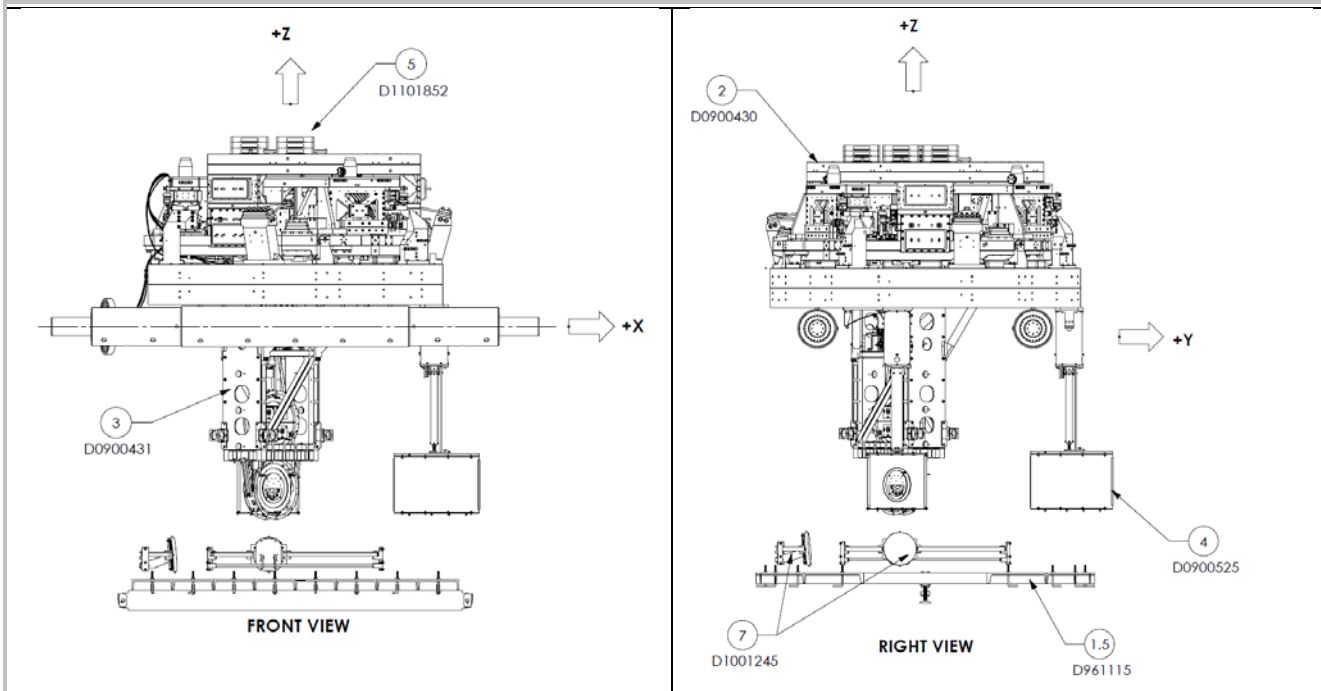

Figure 4: Image of LBSC2 installation (from D0900428, with chamber missing for clarity)

5.1 Prerequisites for Chamber Installation

- The oxide layer removed from the interior of the lower shell of the BSC vacuum chamber, and the BSC chamber certified as “clean”
- All subsystem assembly and testing completed successfully

5.2 Prepare the Chamber for Cartridge Installation

- Install HEPI per [E040011](#)
- Install the cable tray ([D1100430](#)) around the LBSC2 chamber. (*Note: The wire tray support brackets will be different than shown in the drawing, but similar in overall concept/layout; Drawing to be revised.*)
- Install the Platforms ([D1001990](#)) and Module E ([D1002926](#)) around the chamber, per procedure [E1101051](#)
- Install a BSC Chamber Cleanroom around the LBSC2 chamber and clean the chamber exterior and the region around the chamber. Install the leg lifting/lowering devices on all 4 legs.
- Vent the Y-Manifold vacuum volume and set the purge gas flowing per procedure [M1000360](#). Follow the Lockout-Tagout procedure [M990190](#)
- Install the dial indicators on the BSC support tube ends
- Remove the BSC Dome per procedure [E1101162](#)

**LBSC2**

- Install the Walking Plates ([D1002410](#), without railings).
- Remove the LBSC2 Chamber Door per procedure [M1100068](#)
- Install the electrical feed-throughs listed in [D1003089](#), per procedure [M990173](#)
Note: The electrical feed-throughs can be installed later in the sequence.
- Install the field cabling from the electrical feed-throughs to the electronics racks, per **D#s?**
Note: The field cabling can be installed later, but must be done after the cable trays are in place, yet before the cartridge is installed.
- Install the viewports listed in [T1100292](#) for LBSC2 and Adapter LA-1B, per procedures [E1100484](#) and [M990173](#)
Note: The viewports can be installed later in the sequence.
- Install the BSC Chamber Flooring ([D961115](#)) in accordance with the orientation noted in [D1101429](#)
- Insure that the support tubes are level (to within 0.4 mrad) with a precision bubble level and HEPI static adjustment (per procedure [E040011](#))
- Transport the Elliptical Baffles ([D0900525](#)) subassemblies, and associated installation equipment, into the manifold spool adjacent to LBSC2, per procedure [E1101021](#).

completed, approved or checked by:
date:

Version numbers of all subsidiary documents followed:

comments (optional, e.g. deviations, exceptions, problems, "punch-list"):

5.3 Prepare the Cartridge Assembly for installation into the chamber

- Lock down the BSC-ISI stages
- Lock down the BS per [T1100489](#)
- Install tooling/guards to protect the optics (e.g. the "lens caps", etc.) and place the optics on their mechanical/earthquake stops
- Disconnect all cabling/wiring and temporarily tie down to the BSC-ISI assembly with class B cable ties
- Wrap each suspension in appropriate C3 fabric bags

**LBSC2**

completed, approved or checked by:
date:

Version numbers of all subsidiary documents followed:

comments (optional, e.g. deviations, problems):

5.4 Install the Cartridge Assembly into the Chamber

- Insure that all personnel involved have read and understood the
 - completed cartridge installation procedure LIGO-E1200344: [All BSC, Install Completed Cartridge Into Chamber Procedure, aLIGO](#),
 - the specifics of the LBSC2 cartridge installation (CG location, flight path, close approach regions, etc. in [\(E1200322\)](#),
 - the hazard analysis [\(E1200327\)](#) and
 - the critical lift plan [\(E1200328\)](#)
- Follow LIGO-E1200344: [All BSC, Install Completed Cartridge Into Chamber Procedure, aLIGO](#) to install the Cartridge into the Chamber and attach to the SEI Support Tubes.
- Install the railings around the Walking Plates ([D1002410](#)) after landing the Cartridge onto the support tubes
- Remove all temporary cable ties and connect all cabling to the appropriate electrical feed-throughs according to [D1003089](#).
- Unlock the ISI stages
- Remove the protective and lens cap for the BS
- Unlock the BS suspension

completed, approved or checked by:
date:

Version numbers of all subsidiary documents followed:

comments (optional, e.g. deviations, problems):

**LBSC2****5.5 Align the Cartridge Assembly**

- Remove the Spool Adapter LA-1B per procedure [M1000357](#)
- Set up the Initial Alignment System (IAS) equipment in the region of the Spool Adapter LA-1b, per procedure [E1200392](#)
- Follow alignment procedure [E1200392](#) to align the Cartridge within the Chamber.

completed, approved or checked by:
date:

Version numbers of all subsidiary documents followed:

comments (optional, e.g. deviations, problems):

5.6 Install the ITM Elliptical Baffles

- Lock down the BSC-ISI stages per [E1101037](#)
- Lock down the BS per [T1100489](#)
- Install the ITM Elliptical Baffles per [E1101021](#)

completed, approved or checked by:
date:

Version numbers of all subsidiary documents followed:

comments (optional, e.g. deviations, problems):

5.7 Install the Optical Levers Periscope Assembly

- Remove the center flange cover from viewport G2:



LBSC2

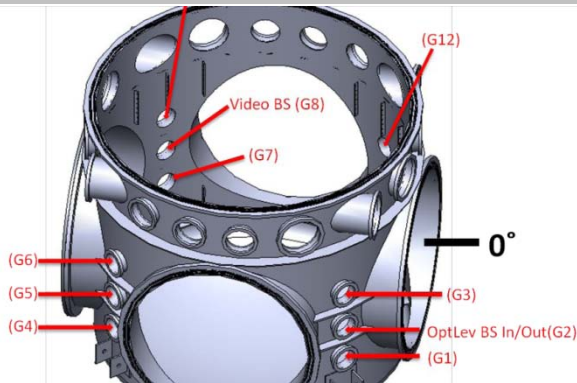

- Install D1100625-BSC2L1 Periscope Assembly per [E1200063](#), sec 4.3. Reference [D1100833](#) for orientation.

5.8 Install the TCS Laser Projection System, In-Vacuum Steering Mirror Assembly

- Lock down the BSC-ISI stages per [E1101037](#)
- Lock down the BS per [T1100489](#)
- Install protective shields on the BS suspension
- Install the TCS CO₂ Laser In-Vacuum Steering Optics Assy, LBSC2 per [D1101851](#).

completed, approved or checked by:
date:

Version numbers of all subsidiary documents followed:

comments (optional, e.g. deviations, problems):

5.9 Clean the Optics

- Inspect the optical surfaces. If cleaning is required, then complete the following steps.
- Lock down the BSC-ISI stages per [E1101037](#)
- Lock down the BS per [T1100489](#)
- Clean the optics if needed. First Contact™ cleaning (per procedure [E1000079](#)) is the preferred method.



LBSC2

completed, approved or checked by:
date:

Version numbers of all subsidiary documents followed:

comments (optional, e.g. deviations, problems):

6 TESTING

Prior to pumping the Y-manifold down to vacuum all active components must pass stand-alone, in-situ testing to see that the assembly behaves properly after the installation procedure and with the field-installed cabling, etc (i.e. phase 3 testing per [M1000211](#)):

- [E1000488](#), “BSC-ISI Testing Procedure, Phase III: Control Commissioning”
- [E1100203](#), “aLIGO SUS BS/FM Post-Installation Testing Procedure”

completed, approved or checked by:
date:

Version numbers of all subsidiary documents followed:

comments (optional, e.g. deviations, problems):