



LIGO Laboratory / LIGO Scientific Collaboration

LIGO- E1200925-v1

Advanced LIGO

25 Oct. 2012

**BSC Cartridge Installation
Hazard Analysis**

Sam Barnum, Dennis Coyne, Brian O'Reilly, Norna Robertson, Calum Torrie

Distribution of this document:
LIGO Science Collaboration

This is an internal working note
of the LIGO Project.

California Institute of Technology
LIGO Project – MS 100-36
1200 E. California Blvd.
Pasadena, CA 91125
Phone (626) 395-2129
Fax (626) 304-9834
E-mail: info@ligo.caltech.edu

Massachusetts Institute of Technology
LIGO Project – NW22-295
185 Albany St
Cambridge, MA 02139
Phone (617) 253-4824
Fax (617) 253-7014
E-mail: info@ligo.mit.edu

LIGO Hanford Observatory
P.O. Box 1970
Mail Stop S9-02
Richland, WA 99352
Phone (509) 372-8106
Fax (509) 372-8137

LIGO Livingston Observatory
P.O. Box 940
Livingston, LA 70754
Phone (225) 686-3100
Fax (225) 686-7189

<http://www.ligo.caltech.edu/>

APPROVAL SIGNATURES

Digitally signed by Calum Torrie
DN: cn=Calum Torrie, o=LIGO Caltech, ou=LIGO,
email=ctorrie@ligo.caltech.edu, c=US

Date: 2012.10.30 11:55:14 -07'00'

Dennis Coyne, LIGO Chief Engineer Date

David Nolting
2012.10.30 15:47:13 -05'00'

David Nolting, Advanced LIGO Safety Coordinator & LLO Site Safety Responsible Date

Digitally signed by John Worden
DN: cn=John Worden, o, ou,
email=worden@ligo.org, c=US
Date: 2012.10.30 11:51:44 -08'00'

John Worden, LHO Site Safety Responsible Date

Brian O'Reilly
Digitally signed by Brian O'Reilly
DN: cn=Brian O'Reilly, o=Caltech, ou=LIGO Livingston Observatory,
email=brian@ligo-la.caltech.edu, c=US
Date: 2012.10.30 16:16:01 -05'00'

Brian O'Reilly, Advanced LIGO LLO Installation Lead Date

Michael Landry
Digitally signed by Michael Landry
DN: cn=Michael Landry, o=LIGO Hanford Observatory, ou, email=michael.landry@ligo.org, c=US
Date: 2012.10.30 15:11:40 -07'00'

Michael Landry, Advanced LIGO LHO Installation Lead Date

 **2012.10.30 12:44:07 -05'00'**

David Shoemaker, Advanced LIGO Leader Date

Digitally signed by Albert Lazzarini
DN: cn=Albert Lazzarini, o, ou,
email=lazz@ligo.caltech.edu, c=US
Date: 2012.10.30 20:59:29 -08'00'

Albert Lazzarini, LIGO Directorate Date

CHANGE LOG

Date, version	Summary of Changes
18 Oct 2012	Initial release for comment (modified from E1200327 BSC2-L1)
25 Oct 2012	<p>1) BIG ONE - is this is now a general HA for ALL Cartridge installs. 2 have now been completed at LHO and one at LLO.</p> <p>As part of this change to general we clarified, noted and identified the following: -</p> <p>2) Identified risk for damage to Gate-Valve Plumbing and Gate Valve (section 2 and hazard 9)</p> <p>3) Noted that some keel plate hole patterns are rotated by 120deg from the that shown in the assembly documentation, adjust x-y of the lifter bale position to compensate for rotation. (section 3.4)</p> <p>4) Spelled out that there is a need to rotate Cartridge to align with chamber, if a rotation of the cartridge is required to align it to the chamber (BSC1,2). (Section 3.5)</p> <p>5) Updated related documents (section 4)</p> <p>6) Identified clearly that the cleanroom will be fitted with a 4" spacer between the two halves to provide clearance for the gate-valve motor box. A narrower version of Platform-C will be used in place of the original Platform-C to avoid contact with the gate-valve plumbing (Section 5.9)</p> <p>7) walking Plate railings will not be reinstalled, due to lack of clearance between them and the incoming Cartridge. (3.8)</p>

1) Scope

This document covers safety concerns related to the installation of the BSC cartridge from the Test/Assembly stand into the BSC Chamber. The cartridge is comprised of the BSC Internal Seismic Isolation (ISI) with all of the optics table payloads which can be lifted and inserted without interference into the chamber.

The scope includes:

- 1) Preparation and liftoff of cartridge from the Test/Assembly Stand.
- 2) Flight of the cartridge from the Test/Assembly stand to the Chamber.
- 3) Insertion of the Cartridge into the chamber.

This document does not cover the issues associated with the individual suspension and seismic systems that are part of the cartridge. Nor does it cover aspects specific to the crane, or handling of optics. These are covered by other documents.

2) Summary of Hazards

The hazards in this work can be broadly divided into the following areas:

- 1) Moving of heavy, delicate and valuable structures with lifting and moving equipment, with potential for shock/impact if dropped or bumped, leading to the following potential failures/hazards:
 - a) Personnel injury (crushing, pinching, falling).
 - b) Damage to equipment, such as:
 - failure/stretching of wires and/or fibers.
 - misalignment of suspension elements.
- 2) Damage to the suspensions or isolation system,
 - a) Impact against the Test/Assembly Stand.
 - b) Impact against the BSC Chamber and Support Tubes.
- 3) Particulate contamination,
- 4) Cartridge dropped,
- 5) Crane failure (without drop) or Power Failure during operation,
- 6) Crane/Structural failure (Overload crane),
- 7) Drop/fall hazard of tools, etc. due to assembly of components at height,
 - a) While putting covers over cartridge.
 - b) During attachment of 3pt Lifter to cartridge.
 - c) When attaching Cartridge to Chamber support tubes
- 8) Crane rotation failure while cartridge suspended.

9) Damage to Gate-Valve Plumbing and Gate Valve.

3) Overview (Note: all pictures are examples from BSC6, but are applicable to all BSC)

3.1 Attach the three (3) Lift Hook Receivers (D1000753) on the ISI Keel-plate, if not already present (See D1000756 for layout and use Bumax-88 3/8"-16 Screws, Torque, 13-15 ft-lb).

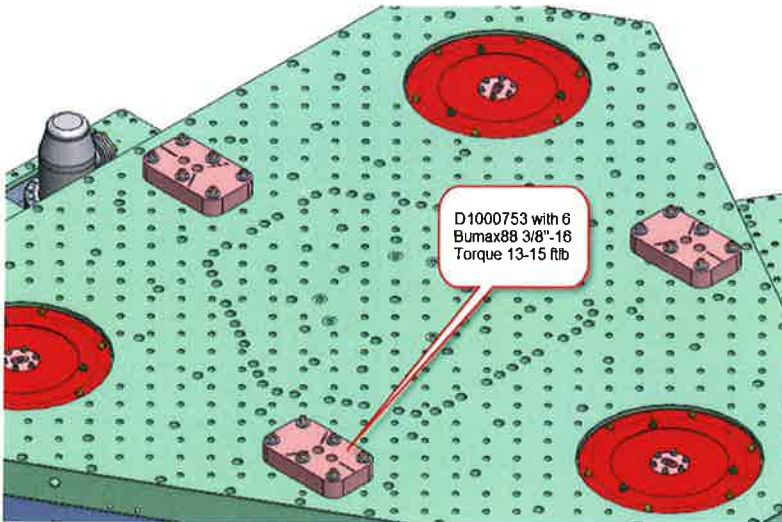

3.2 Attach 3pt Lifter to Lift Hook Receivers (D1003140), use 5/8"-11 Grade9, equivalent or better (91271A802, 90201A531), 125-128 ft-lb

Note that the cartridge should be covered with C3 covers at this time (not shown)

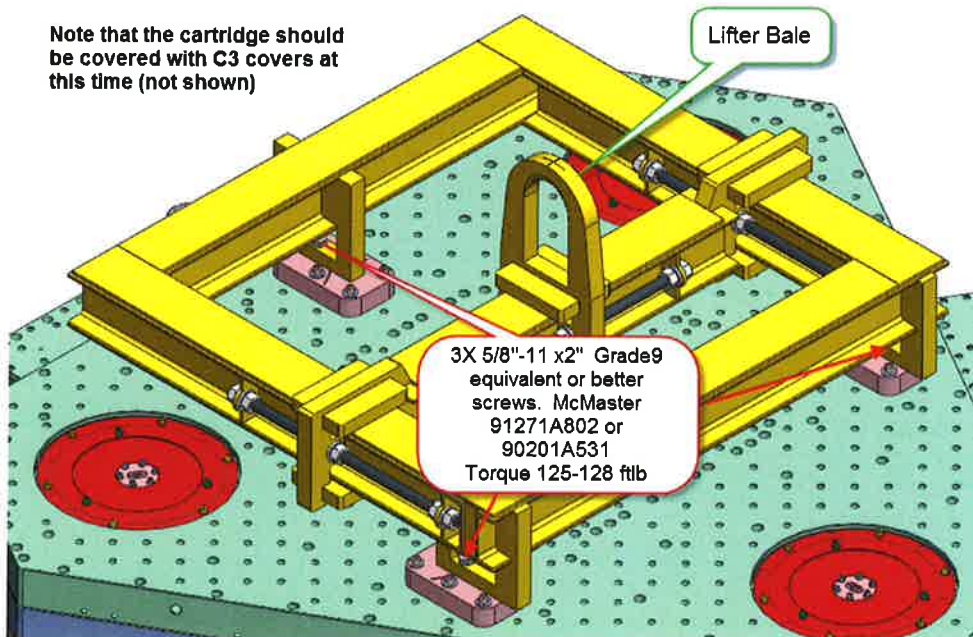

3.3 Crane In position above Cartridge and Test Stand

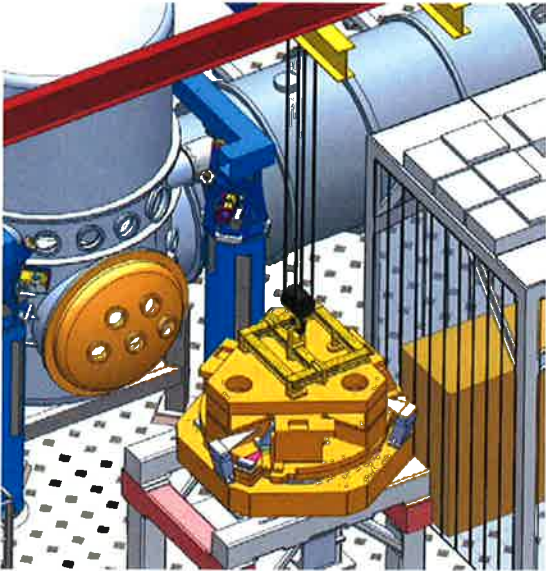

- 3.4 Adjust 3pt lifter bale** (shown below with load cell attached) to predicted X-Y CG location (some keel plate hole patterns are rotated by 120deg from the that shown in the assembly documentation, adjust x-y of the lifter bale to compensate for rotation.) Then **Check Cartridge weight:** Lift cartridge from test-stand with load cell and crane, If load-cell starts to exceed 10,000lb, stop, and set cartridge back down. Reduce cartridge weight and try again. Record the final total weight, set back down and remove load cell. Record the specific load cell and any needed deviations in the intended payload for the cartridge. If there is a 2" or more gap at any point between the mounting surface of the Test Stand and the mounting surface of the cartridge, the cartridge must be re-leveled. Target gap at any point will be ~ 1/4"



(3pt. Lifter & Load Cell, shown while not attached to cartridge)

- 3.5 Rotate Cartridge to align with chamber,** if a rotation of the cartridge is required to align it to the chamber (BSC1,2): Insure a protective tarp with clean side up has been placed on the floor in the area where the cartridge rotation will take place (cartridge cover may contact floor otherwise). Attach 2 to 4 taglines to 3pt lifter (to rotate cartridge or serve as backup) Lift cartridge to clear Test Stand and move to designated area over tarp. Lower cartridge to minimum practical height without suspensions contacting the floor. Move staging from around test stand, into place to access stage0 if rotation "by hand" is to be done. Using either taglines or the "by hand" method, rotate cartridge to align with chamber orientation. If pivot on hook becomes jammed, return cartridge to test stand. There is clearance to allow this.

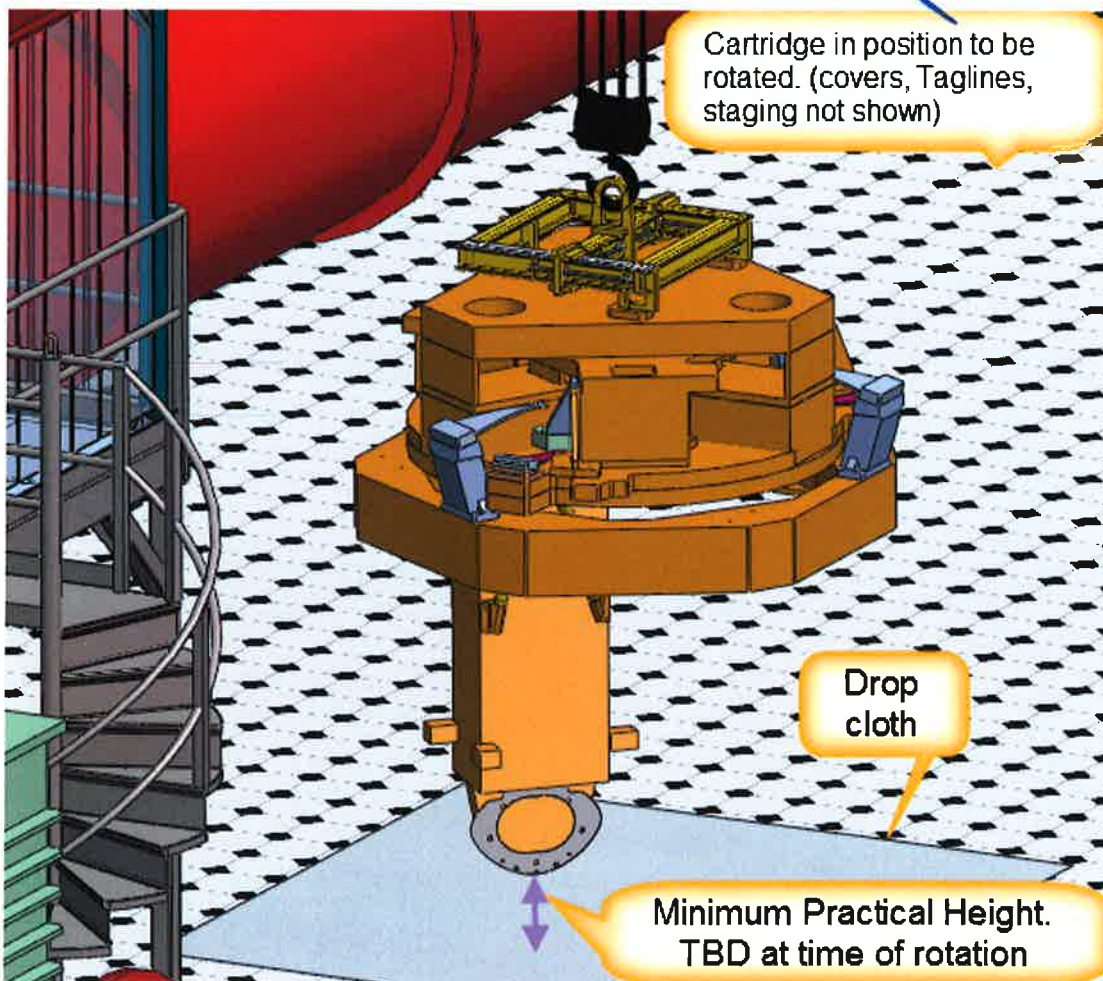

- 3.6** Lift cartridge up to height to clear BSC Clean-room (max height). BSC Clean-room should already be at minimum height (just above spools), Walking Plates (D1002410) and Platforms (D1001990) should be in place without railings, around chambers (See install procedure E1101051). Clean-room clearance ~8"

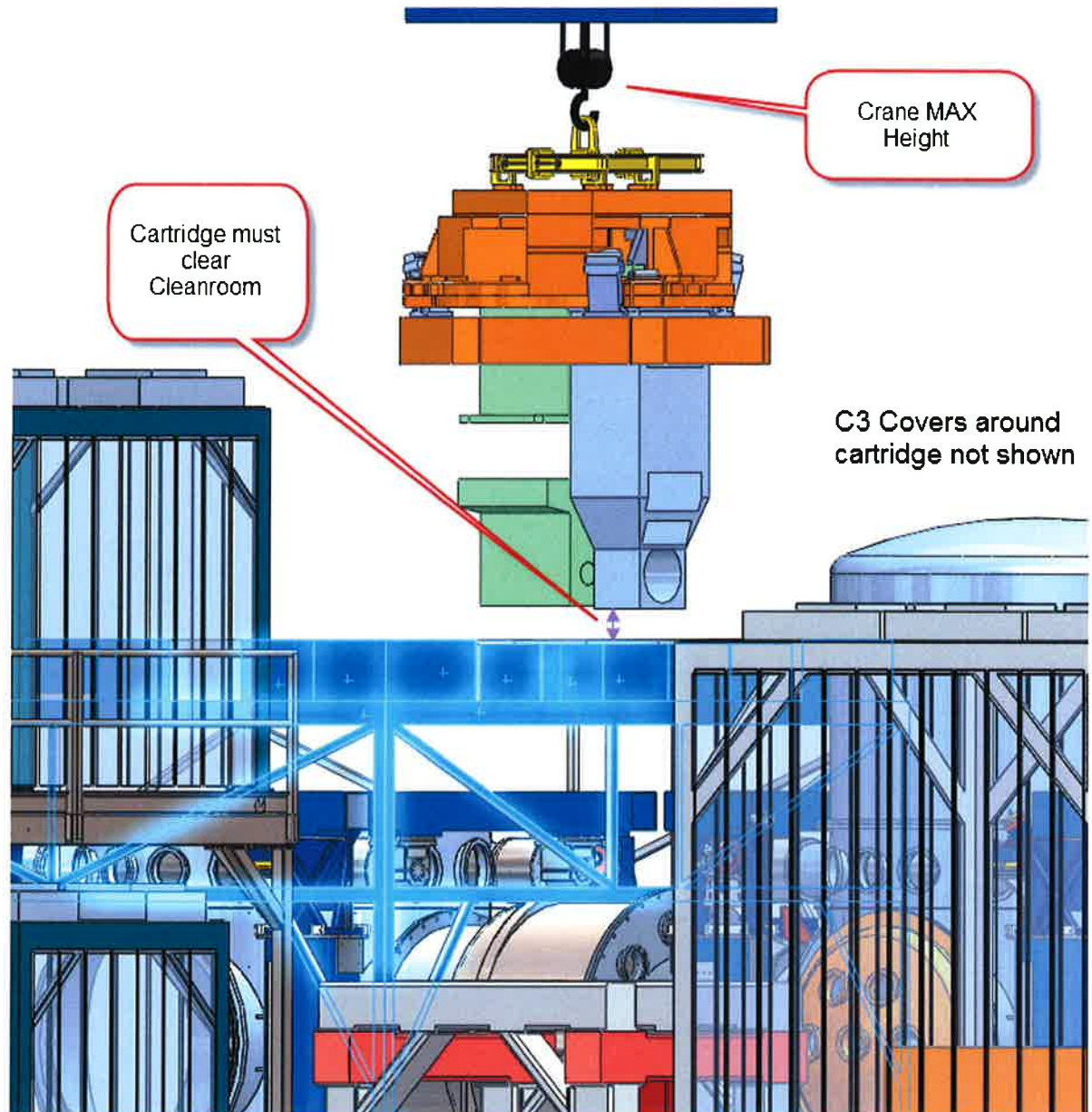

3.7 Move crane to a point centered above target BSC chamber, and BSC Clean-room

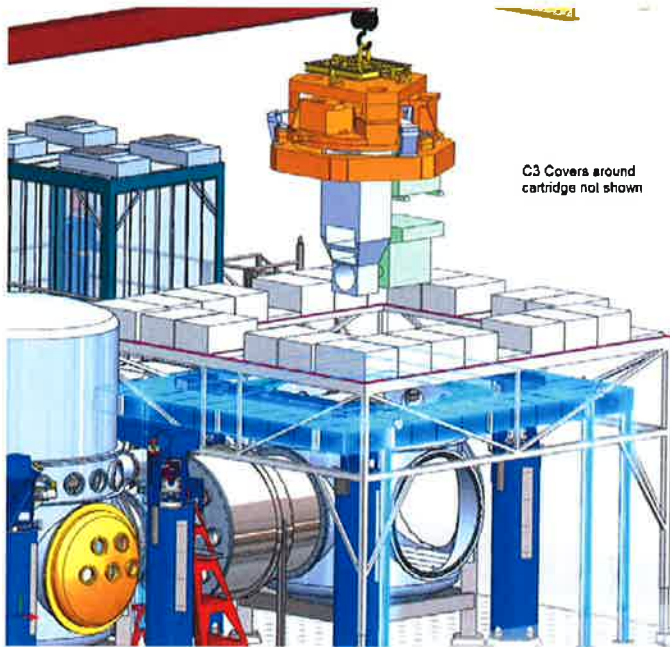

3.8 Raise BSC Clean-room back up to max height, Walking Plate railings will not be reinstalled, due to lack of clearance between them and the incoming Cartridge. Fall arrest system will be used (personal harness, lanyard, anchor points,) to prevent falls.

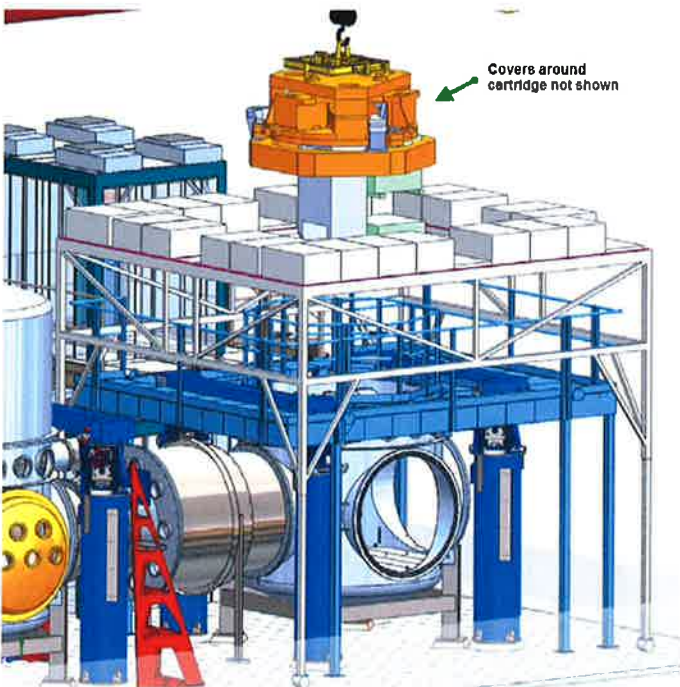

3.9 Lower cartridge to just above chamber, and roll up outside cover to expose stage0, remove fabric cover from chamber. Continue to lower cartridge onto support tubes in chamber.

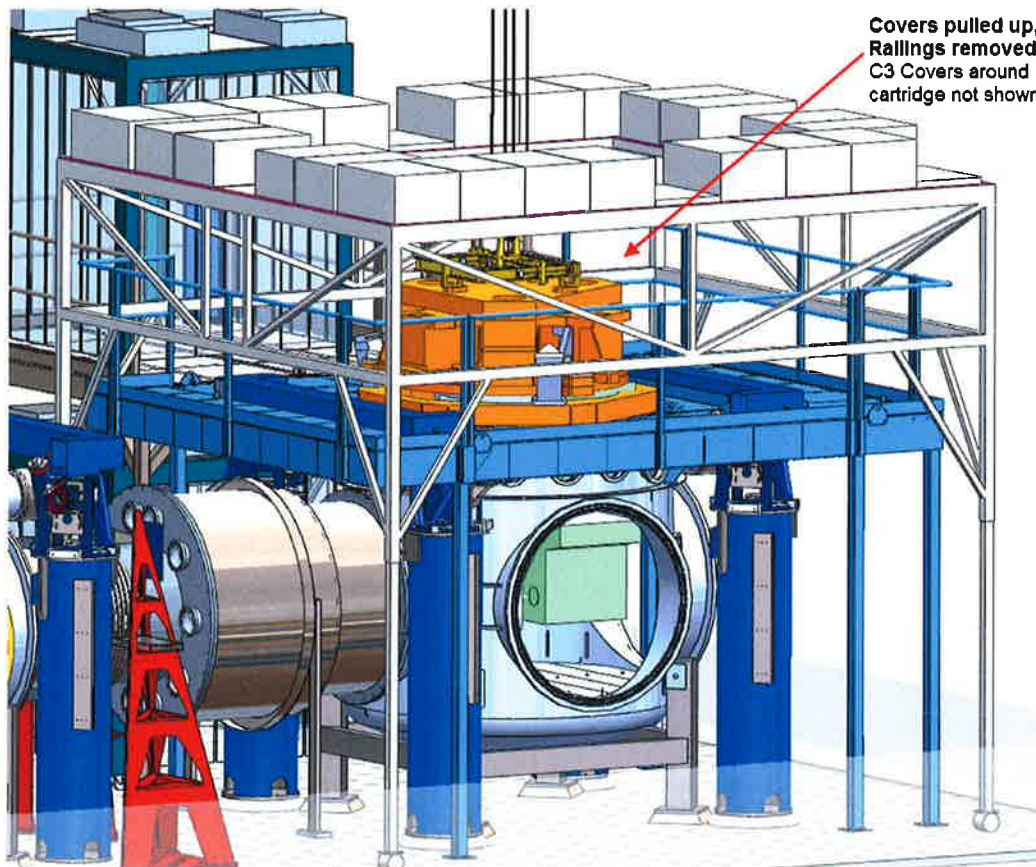

3.10 Insert 3/8"-24 x 2" screws into all 14 holes. Torque 21 ft.lb, Then remove 3pt Lifter, close up clean room, finish removing C3 covers.

4) Related Documents

- [LIGO-E1200023](#): aLIGO Chamber Installation Procedures.
(See related documents specific to the BSC Cartridge being installed)
- [LIGO-E1200900](#): BSC Installation Procedures (from sub-systems)
- [LIGO-E1200901](#): BSC Safety Procedures(associated with install)
- [LIGO-E1101051](#): BSC Work Platforms Assembly Instructions
- [LIGO-E1200344](#): All BSC, Basic Cartridge Install, aLIGO
- [LIGO-E1101017](#): Cartridge Lifting Hardware, Loading Analysis.

5) Hazard Analysis

Each hazard, and mitigation approach or measure, is listed in the severity table in the next section

5.1 While moving heavy, delicate and valuable structures using lifting and moving equipment, there is potential for injury, shock and/or impact if structures are dropped or bumped.

- Personnel injury (crushing, pinching, falling)

A minimum number (4) of personnel must be trained for, and follow safety rules of the lifting equipment to be used. Safety glasses, shoes, and hardhats must be worn by personnel involved in the lifting and transporting of the Cartridge. At no time should work be done above head height while people are directly below.

- At no time should any person be beneath a suspended cartridge.
- Damage to equipment (from shifting or vibrations)
- Vibrations, Accelerations and Decelerations during liftoff, transport, and placement have the potential to damage items held in the suspensions or between the stages of the ISI. Therefore the ISI and items in the SUS frames must be locked down per the checklists and references in [LIGO-E1200900](#) & [LIGO-E1200344](#)

5.2 Damage to the suspensions or isolation system from Impact

- Impact can cause damage directly to the suspension frames, Test Stand, or Chamber. Resulting movement of the suspended items in the frames during an impact can cause secondary damage. Chances of contact with optics table payload is significantly reduced by removing any items that might interfere with the Support Tubes or Chamber. In addition there are lateral moves (laid-out in BSC Requirements and procedures.. in: [LIGO-E1200900](#)) to avoid contact with potentially interfering items. The ISI and items in the SUS frames must be locked down per applicable checklists and references in [LIGO-E1200900](#) & [LIGO-E1200344](#).

5.3 Particulate contamination

- To protect delicate optics and other components, all guards, covers and caps, must be in place. All personnel must be trained and follow the detailed procedure and checklist to ensure all of the required items are in place
- Fabric covers are used over the entire cartridge assembly to catch particulates generated by the crane.

5.4 Cartridge Drop

- Failure of the lifting apparatus causing the cartridge to drop, could result in serious injury and loss of a significant portion of the cartridge hardware. Thus no person will be allowed below the cartridge or within a safety radius of it during liftoff, transport or

set-down. Only the crane operator and persons watching for close encounters and/or providing hand signals, shall be allowed in the area where the lift is being made. All others shall stay at a safe distance (20-feet minimum) away from lift activities. The exception to this is in the very early and late stages of liftoff and set-down while the cartridge is only a few inches away from the support tubes, which would shield anyone from the short drop of the cartridge. The cartridge will need to be inspected and guided at these two times. The dropping hazard is mitigated overall by the use of lifting hardware that has a 3 times yield, designed-in, safety factor. It should also be noted that it is recommended that bystanders refrain from talking/making noise that may disturb the concentration and communication of the personnel involved in the lift.

5.5 Failure of crane to operate or power failure during operation

- A failure of the crane lifting mechanism, or power loss during transport will result in the crane locking in place. This is not a safety problem, and covers will prevent contamination. See critical lift plan in [LIGO-E1200901](#).

5.6 Structural failure of Crane

- The crane will not be operated beyond rated capacity. All items will be pre weighed, and must only be the ones expected per plans ([LIGO-E1200900](#) and [LIGO-E1101017](#)) to be part of the cartridge (no additional unexpected parts).

5.7 Drop/fall hazard due to assembly of components at height

- To prevent falls and dropped items from height, platforms and walking plates with kick panels and railings will be in place as needed around the BSC chamber. Also a Fall Arrest System will be used when railings cannot be used.

5.8 Crane does not allow cartridge to rotate, or jams at partial rotation

- Cartridge can be returned to test stand if hook pivot becomes stuck.

5.9 Cleanroom or platforms impact the Gate-Valve or plumbing.

- The cleanroom will be fitted with a 4" spacer between the two halves to provide clearance for the gate-valve motor box. A narrower version of Platform-C will be used in place of the original Platform-C to avoid contact with the gate-valve plumbing. Reference [LIGO-E1101051](#) (BSC Work Platforms), for setup and configuration of the platforms round the BSC Chambers.



LASER INTERFEROMETER GRAVITATIONAL WAVE OBSERVATORY

6) Hazard Analysis Severity Table (The number in brackets is a reference back to section 2 summarizing the hazard)

Item (Ref)*	Hazard	Cause	Effect	Unmitigated Severity	Unmitigated Probability Level	Unmitigated Risk Index	Comment	Mitigation	Mitigated Severity	Mitigated Probability Level	Mitigated Risk Index
1 (2.1)	Fingers/hand/arm pinching/crushing hazard	Between Cartridge and Support tubes on Test Stand or in Chamber	Injury to personnel	Critical	Occasional	2C		A minimum number (4) of personnel must be trained for and follow safety rules of lifting equipment being used	Negligible	Remote	4D
2 (2.2)	Cartridge impact anywhere other than mounting surfaces.	Interference with support tubes, Test Stand or chambers	Damage to mostly suspended items.	Critical	Probable	2B	Damage concern mostly to suspensions during lift or lower, to stand or chamber	Remove interfering items & lateral moves of cartridge to clear obstacles.	Marginal	Remote	3D
3 (2.3)	Particulate contamination	Debris falling from above: crane etc. Removal of covers/caps	damage to environment	Marginal	Probable	3B		C4 Cloth covers for cartridge and suspended components	Marginal	Remote	3D
4 (2.4)	Payload drop hazard	Improper use of interface tooling, linkages, crane	Injury to personnel; damage to equipment	Critical	Remote	2D	3X or better safety factor on all lifting equipment (industry standard)	Personnel must be trained and follow detailed procedure and checklist.	Critical	Improbable	2E
5 (2.5)	Failure of lifting mechanism, power outage	Lifting equipment not serviced or used as per instructions, power outage	Nuisance, lost time	Marginal	Remote	3D	Final weight of cartridge measured, insure crane within operating spec. at all times.	lifting equipment should be inspected and maintained, so that a failure is unlikely. Do not operate at time when a power outage is likely.	Negligible	Improbable	4E
6 (2.6)	Crane, structural failure	Overloaded crane, poor crane related maintenance	Injury to personnel; damage to equipment	Critical	Remote	2D		All items to be lifted pre weighed, Test lift, Proper crane maintenance	Critical	Improbable	2E
7 (2.7)	Assembly of components at height	On top of, or below Cartridge and above Support tubes	Injury to personnel; damage to equipment	Critical	Remote	2D		Use barrier plates and railings as instructed, and personnel must wear safety glasses ,shoes ,hard hats	Critical	Improbable	2E
8 (2.8)	Crane rotation failure	Hook Birnds	Wrong orientation	Marginal	Remote	3D		Return cartridge to test stand, repair crane	Negligible	Improbable	4E
9 (2.9)	Gate Valve or plumbing damage	Impact with cleanroom/platform	XY arm Vacuum leak	Critical	Remote	2D	Spacer added to cleanroom to clear gatevalve	New platform -C to clear plumbing/valve, close gatevalve at cryopump	Marginal	Remote	3D

7) Key

Key to table in section 6

Severity	Category	Definition
Catastrophic	1	Death or permanent total disability, system loss, major property damage or severe environmental damage.
Critical	2	Severe injury, severe occupational illness, major system or environmental damage.
Marginal	3	Minor injury, lost workday accident, minor occupational illness, or minor system or environmental damage.
Minor	4	Less than minor injury, first aid or minor supportive medical treatment type of occupational illness, or less than minor system or environmental damage.

Probability	Level	Definition
Frequent	A	Likely to occur frequently or continuously experienced
Probable	B	Will occur several times in the life of an item
Occasional	C	Likely to occur some time in the life of an item
Remote	D	Unlikely but possible to occur in the life of an item
Improbable	E	So unlikely, it can be assumed occurrence may not be experienced.

PROBABILITY

SEVERITY OF CONSEQUENCE	PROBABILITY				
	E Improbable	D Remote	C Occasional	B Probable	A Frequent
1 Catastrophic					
2 Critical					
3 Marginal					
4 Negligible					
Hazard Risk Index	Risk Code Criteria				
1A, 1B, 1C, 2A, 2B, 3A	<p>Unacceptable (Directorate decision required) Undesirable (Directorate decision required) Acceptable with review by Directorate Acceptable without review</p>				
1D, 2C, 2D, 3B, 3C					
1E, 2E, 3D, 3E, 4A, 4B					
4C, 4D, 4E					

**LBSC3**

AUTHOR(S)	DATE	Document Change Notice, Release or Approval
Calum Torrie, Kate Gushwa	Dec 4th, 2012 12:20pm	See LIGO DCC record Status

Instructions on the use of this document:

- 1) *Keep this document, and its linked documents, available on a cleanroom compatible computer or Lenovo at all times during installation.*
- 2) *Use this document as a checklist. Check off each step as it is completed. There is a green box at the end of each subsection to record the name of the person(s) who completed and/or approved the work, date, and any comments or notes. In particular, note any discrepancies or deviations and augment with any missing information. If additional notes are too cumbersome to include within the body of this document, then electronically attach them to the completed procedure.*

ALL NOTES MUST BE RECORDED IN THE COMPLETED VERSION OF THIS DOCUMENT (NOT IN OTHER NOTEBOOKS OR FILES).

- 3) *Once completed, file the document in the LIGO Document Control Center (DCC) as a new version of the procedure. Add a note that this is a completed procedure.*
- 4) *File any significant notes or data from the completed procedure in the electronic logbook (such as any deviations). As a minimum, note in the electronic logbook that the installation was completed in accordance with this procedure (cite document number and revision).*

11/29/2012 - Internal - Kate in Red. Calum in Green



LBSC3

Table of Contents

1 APPLICABLE DOCUMENTS.....3

2 SCOPE7

 2.1 Major Assemblies 9

3 REQUIRED EQUIPMENT 11

4 PROCEDURE FOR CARTRIDGE ASSEMBLY 12

 4.1 Install BSC-ISI onto the test stand 14

 4.2 Prerequisites for Cartridge Integration..... 15

 4.3 Perform final BSC-ISI testing/characterization prior to payload integration 15

 4.4 Install fiducial markers..... 16

 4.5 Attach alignment template for ITMX..... 16

 4.6 Weigh suspension payloads 16

 4.7 Install SEI balance masses 17

 4.8 Install ITM and SUS payload..... 17

 4.9 Phase 2a SUS Testing 17

 4.10 Detach ITMX Lower Structure (LS) 18

 4.11 Install Ring Heater 18

 4.12 Install glass masses and weld fibers 18

 4.13 Re-attach Lower Structure..... 19

 4.14 Preparing the full quad..... 19

 The following notes include information on lacing cables, suspending the suspension, coarsely aligning it, setting L-brackets, setting BOSEMs and damping..... 19

 4.15 Perform fine IAS (align the Optics) 20

 4.16 Phase 2b SUS testing 20

 4.17 Re-install balance of SUS payload 21

 4.18 Post-Integration, Cartridge Testing..... 21

5 PROCEDURE FOR INSTALLATION INTO THE CHAMBER 21

 5.1 Prerequisites for Chamber Installation 23

 5.2 Prepare the Chamber for Cartridge Installation 23

 5.3 Prepare Cartridge Assembly for Installation into the Chamber 26

 5.4 Prepare LVEA..... 27

 5.5 Install the Cartridge Assembly into the Chamber 27

 5.6 Align the Cartridge Assembly 29

 5.7 Install the Arm Cavity Baffle 29

 5.8 Install the TCS CO₂P Steering Mirror 1 Assembly 30

 5.9 Final Operations 30

6 TESTING..... 32



LBSC3

1 APPLICABLE DOCUMENTS

All of the documents required for the installation of LBSC3 are listed below. Background and reference materials have been excluded to streamline the use of this installation procedure. Users may fill in the revision numbers of documents in the table.

Documents have been subdivided into the following categories, which are linked to this procedure in the DCC as “Related Documents”:

- aLIGO Systems, BSC3-L1 Top Level Chamber Assembly and Primary Chamber-Level Build Documents
- BSC Systems Level Supplementary Chamber-Level Build Documents
- aLIGO Installation Procedures (from sub-systems)
- aLIGO Safety Procedures (associated with install)
- aLIGO BSC Test Procedures (associated with install)
- aLIGO Alignment Procedures (associated with install)
- aLIGO, SUS, BSC/HAM INSTALLATION TOOLING

Table 1. LBSC3 Document List

Document	Rev	Title
D0900492		aLIGO Systems, BSC3-L1 Top Level Chamber Assembly
D0900493		AdvLIGO VE BSC3-L1, Vacuum Equipment Assembly
D1000513		HEPI ASSEMBLY, BSC aLIGO
D0900494		AdvLIGO SEI BSC3-L1, XYZ Local CS for ISI Table
D1003064		AdvLIGO BSC3-L1 ISI Table, Payload & Suspended Mass Assembly
D0900495		AdvLIGO SUS BSC3-L1, XYZ Local CS for ITMX Missing cabling info.
D1003371		AdvLIGO SUS BSC3-L1, XYZ Local CS for SLC Arm Cavity Baffle
D1200679		AdvLIGO SUS BSC3-L1, XYZ Local CS for TCS CO2P Steering Mirror Sub-Assy
D1003090		Flange Layout – L1 Beam Splitter Chamber 3 (BSC3) ITMX
D1200059		CABLE HARNESS ROUTING CONFIGURATION, BSC-3
D1101429		ALIGO, BSC FLOORING ORIENTATION DETAILS
D1201150		aLIGO, SUS, OPTIC TABLE .38-16 BSC1-H1, L1/BSC3-H1, L1 FIDUCIAL KIT
E1101165		BSC3 L Top Level Chamber Assembly BOM
D1201362		BSC Systems Level Supplementary Chamber-Level Build Documents
D1201362		BSC Systems Level Supplementary Chamber-Level Build Documents

**LBSC3**

E1000337		AdvLIGO Detailed Mass Properties-CG Report BSC Tables (LLO)
E1200345		Schnupp Effect: ETM /ITM MECHANICAL CLEARANCES & COOKIE CUTTER 'BLANK' FEASIBILITY
D1002124		Stand, Test, BSC-ISI+Quad + HAM-ISI, aLIGO
D1101271		ALIGO BSC ISI OPTICAL TABLE HOLE TABULATION
D1101775		aLIGO, ELECTRICAL FEEDTHROUGH TYPES, TYPICAL SUBFLANGES, AND PORT CONFIGURATIONS
D1100430		BSC CABLE TRAY ASSEMBLY
D1101050		ALIGO, SUS ALIGNMENT TEMPLATE ASSY.
D1003140		Lifting Bar, 3 Point, BSC Cartridge, aLIGO
D1000744		Lift Hook Receiver, ALIGO BSC ISI
D1001990		Platform Walkway, BSC Installation
D1002926		Module-E, BSC Cartridge Installation, aLIGO
D1002410		Walking Plates, BSC Chamber, Top, aLIGO
T1100292		Viewport Source List
T1000746		Viewports Subsystem Final Design Document
G1000125		aLIGO BSC-ISI, HAM-ISI, and HEPI Basis and Naming Conventions
D0901346		Advanced LIGO Quadruple Suspension
T050213		ETM/ITM Monolithic Stage Fabrication and Assembly
T1100594		Measurements to determine compliance after welding of the Monolithic Stage of the Quadruple Suspension
E1200900		aLIGO Installation Procedures (from sub-systems)
E1200344		All BSC, Install Completed Cartridge Into Chamber Procedure, aLIGO
E1200927		BSC1-L1 Requirements and Procedure, Cartridge Flight and Insertion into BSC Chambers, aLIGO Need LBSC3 equivalent – Sam B 12/4
E040011		Installation Specification - HEPI Assembly and Installation Procedures (includes the HEPI static positioning adjustment procedure as well)
E1101162		BSC Dome Removal Procedure
M1200375		LLO BSC Door Removal and Installation Procedure - Mike Meyer updated
E1101051		aLIGO BSC Work Platform Assembly Instructions
T1100174		Weighing ALL assemblies that are mounted to a HAM isolation table, BSC isolation table or a BSC stage 0

LBSC3

T1100406	Quad cartridge installation procedure check list (e.g. quad lock down)
E1200888	QUAD Reaction Chain Glass Build Procedure
G1100850	Illustration of aLIGO TCS Ring Heater and UHV Cable Installation Unapproved
E1100810	Arm Cavity Baffle Installation/De-installation Procedure Needs work. Lisa 10/10
M990173	Conflat Flange Assembly Procedure
E1100484	Assembly & Installation Specification for the aLIGO, High Quality, Viewports Section 9 Installation had no content. John W working on it 11/05. Section 9 was deleted from v7. Is there another install doc for this?
E000121	Hanford Checklist - Spool Removal Need to find LLO version
M1000360	LLO Vent Isolatable Volumes Procedure
M990180	LLO Large GNB Valve Operating Procedures
E1000079	First Contact™ Procedure
E1100439	General Optics Cleaning Procedure
T1200321	Guidelines on Protecting the Cavity Optics in Chamber wrt First Contact
T1200198	First Contact Application Layer Scenarios
E1101037	aLIGO BSC ISI/Quad Installation Procedure
E1200901	aLIGO Safety Procedures (associated with install)
E1200925	BSC Cartridge Installation Hazard Analysis, aLIGO
E1100814	Cartridge Assembly Hazard Analysis
E1000890	SLC Arm Cavity Baffle Install Hazard Analysis
E1000252	BSC Installation Repair arm and HAM Installation arm Hazard Analysis
E1101017	Cartridge Lifting Hardware, Loading Analysis
E1200950	Critical Lift Plan for the aLIGO BSC1-L1 Cartridge Installation Need LBSC3 version – Sam B 12/4
LIGO-E1200925	BSC Cartridge Installation (Universal) Hazard Analysis
E1200902	aLIGO BSC Test Procedures (associated with install)
M1000211	Subsystem-Level and System-Level Testing Requirements
E1000486	aLIGO BSC-ISI Testing Procedure, Phase I: Assembly Validation
E1000487	aLIGO BSC-ISI Testing Procedure, Phase II: Integration Process
E1000488	aLIGO BSC-ISI Testing Procedure, Phase III: Control Commissioning

**LBSC3**

E1000495		aLIGO SUS QUAD Suspension Testing and Commissioning Documentation
E1000494		aLIGO SUS Quad Suspension Metal Build Testing Procedure
E1000892		Arm Cavity Baffle Fabrication, Install and Test Plan Needs work. Mike S. 10/10
E#?		TCS steering mirrors test document? Mindy 10/10
G1100693		Ideal Order/Contents of aLIGO QUAD Testing / Commissioning
E1200903		aLIGO Alignment Procedures (associated with install)
E1200393		Initial Alignment Procedure –LBSC3 Needs updating
D1200905		Alignment Monument Layout, LLO Corner Station, BSC Mechanical Test Stands No file
E#?		Alignment Procedure for the TCS CO ₂ Laser In-Vacuum Steering Optics Assy, L1-BSC3 Mindy 10/10
D1101674		aLIGO, SUS, BSC/HAM INSTALLATION TOOLING
E1101131		BSC Test Stand, Quad, TMS, Tooling clearances
D1001730		Sketch of Test Stand with respect to the FMP cartridge tooling
E1100520		Key safety information associated with the FMP supplied Genie's, lifts and carts
D1001847		aLIGO, ASSEMBLY, 5-AXIS TABLE
D1002527		aLIGO, SUS, ELEVATOR ASSEMBLY, BSC ARM
D1100886		MODIFIED GENIE LIFT FORKS
E1100832		BSC Repair Arm User Guide
D1200482		aLIGO Spreader Bar, HAM / BSC Repair Arm
D1001221		Lower Structure Assembly Tooling (LSAT) Assembly

[M990190](#) Lockout-Tagout Procedure – is referenced in Section 5.2 but not included in table.



LBSC3

2 SCOPE

This document covers the installation of interferometer components and assemblies into the LBSC3 chamber, shown in Figure 1, Figure 2a and Figure 2b. Refer to LIGO-D0900492: [aLIGO Systems, BSC3-L1 Top Level Chamber Assembly](#)



Figure 1 LBSC3 chamber with vacuum equipment and HEPI

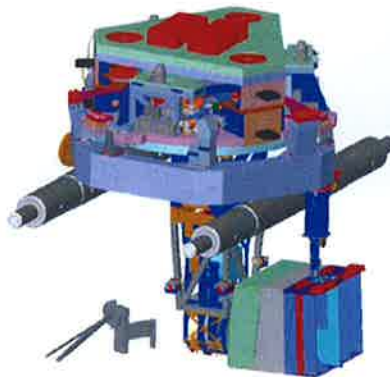

Figure 2 LBSC without vacuum equipment

LBSC3

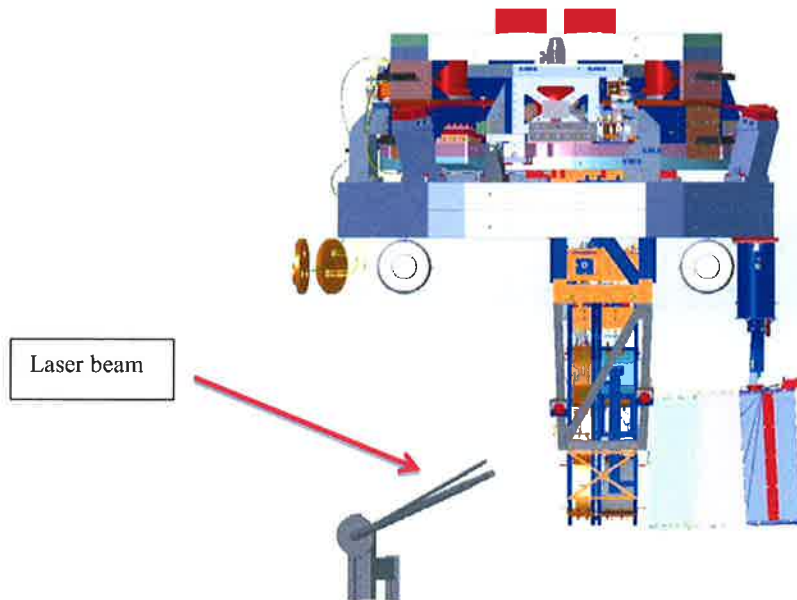

Figure 3 LBSC3 without vacuum equipment





The following is a rough overview of the installation procedure:

- The BSC ISI is fastened to the BSC Mechanical Test Stand ([D1002124](#)) see also figure 4.
- The “cartridge assembly” (payload elements on the optics table and stage 0 of the BSC-ISI) is assembled on the test stand. See figure 5 and figure 6.
- The cartridge assembly is aligned on the test stand.
- The cartridge assembly is lifted, flown to the chamber, and lowered into position on the BSC support tubes.
- Remaining assemblies (Arm Cavity Baffle) are integrated in chamber. Arm cavity Baffle is not included on test stand.
- The cartridge assembly and optical elements are aligned in chamber.

**LBSC3****2.1 Major Assemblies**

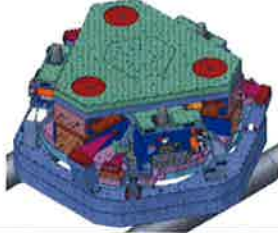
The installation includes the following major assemblies:

Table 2. LBSC3 Major Assemblies

Subsystem	Assy Dwg	Sub-Assembly	Image
SEI	D0900494	BSC ISI assembly: <ul style="list-style-type: none">• BSC ISI (D0901182)• Balance masses (D1003064)• Bolts to attach to support tubes (D0900494 pg 2)	
SYS	D1201150	Optic Table .38-16 Fiducial Kit	
SUS	D0900495	ITMX assembly: <ul style="list-style-type: none">• Quad suspension assembly (D0901346)• Vibration Absorbers (D1002424)• Optics Cap (D1100052)• TCS Ring Heater assembly (D1001838 & D1001895)• Dog clamps (D0900445)	
AOS/SLC	D1003371	Arm Cavity Baffle assembly (D1200580) No file	



LBSC3

AOS/TCS	D1200679	TCS CO ₂ P Steering Mirror 1 assy (D1101013) Unapproved version	
FMP	D1101429	BSC Floor assy (D961115)	
SEI/SYS	D1003090 D1101775	Flange Layout Electrical Feedthrough Types	 (Picture like BSC6/8)
SYS	D1200112	Cable Harness Routing	Need picture
AOS/SLC	T1200292 Viewport Source List	T1000746 for pictures (add additional pics like BSC6/8) A bit confusing.	
Cable Tray Group?	D1100430	BSC Cable Tray Overall Assembly needs revision to as-built (as being built) design Scott 10/25	
HEPI	D1000513	HEPI Assembly, BSC aLIGO	



LBSC3

3 REQUIRED EQUIPMENT

The referenced documents call out the equipment and parts/assemblies required to complete a given task. To assist with setting up for installation, a general list of required equipment is given below:

- Bill of Materials ([E1101165](#))
- SC/HAM Installation Tooling ([D1101674](#))
 - Genie Lift with 5 Axis Table (page 3) – *transport Upper Quad to test stand*
 - Scissors Lift with 5 Axis Table (page 8) – *transport Lower Quad to test stand*
 - 5 Axis Table with Elevator on BSC Arm (page 10) – *repair Lower Quad (in chamber)*
- BSC Repair Arm User Guide ([E1100832](#)) – use in addition to [D1101674](#) (page 10). This is the main “control” document on the arm if there are questions, conflicts. **E1100832 highlighted sections need to be updated.**
 - BSC Installation Arm Assembly ([D1101853](#))
 - BSC Repair Arm Assy Flange Mount ([D1001617](#))
 - Spreader Bar ([D1200482](#))
- Also refer to list at the start of [E1200344](#) (E1200344 is specific to the flight of the cartridge and has a list of equipment that should be cross referenced at this point) – **we are working on integrating the list in E1200344 into this document (and other similar)**

LBSC3

4 PROCEDURE FOR CARTRIDGE ASSEMBLY

The ITMY is the major optics assembly that will be integrated into the LBSC3 cartridge. The Arm Cavity Baffle is not part of the cartridge assembly because it interferes with the test stand.

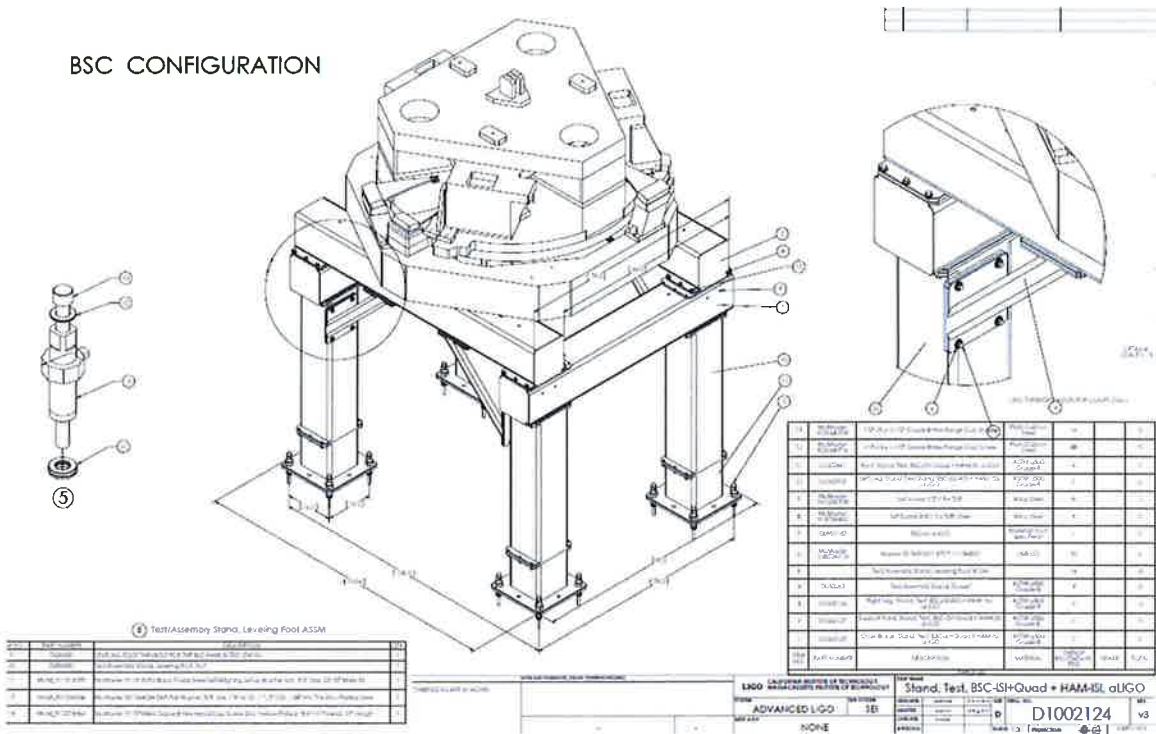

Figure 4 BSC Mechanical Test Stand, refer to (D1002124)



LBSC3

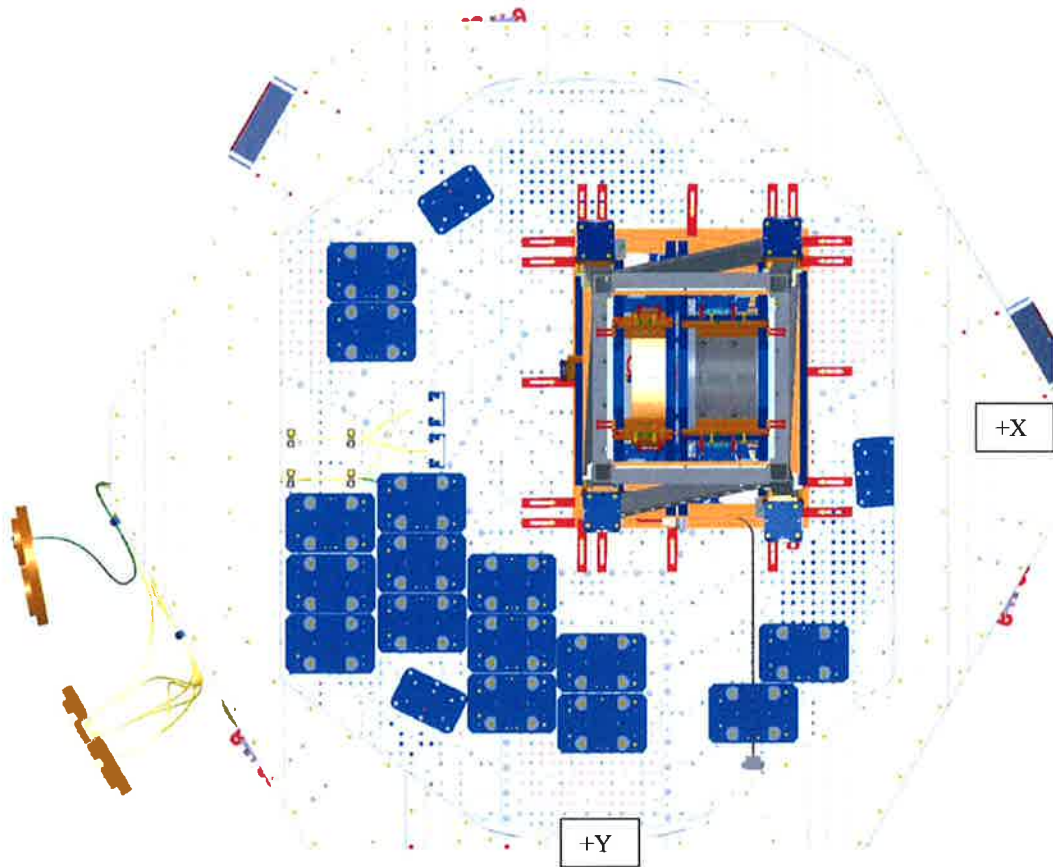

Figure 5 LBSC3 top-level assembly, bottom view looking up. Refer to D0900492: [aLIGO Systems, BSC3-L1 Top Level Chamber Assembly](#) (No Arm Cavity baffle as view is of test stand configuration.)



LBSC3

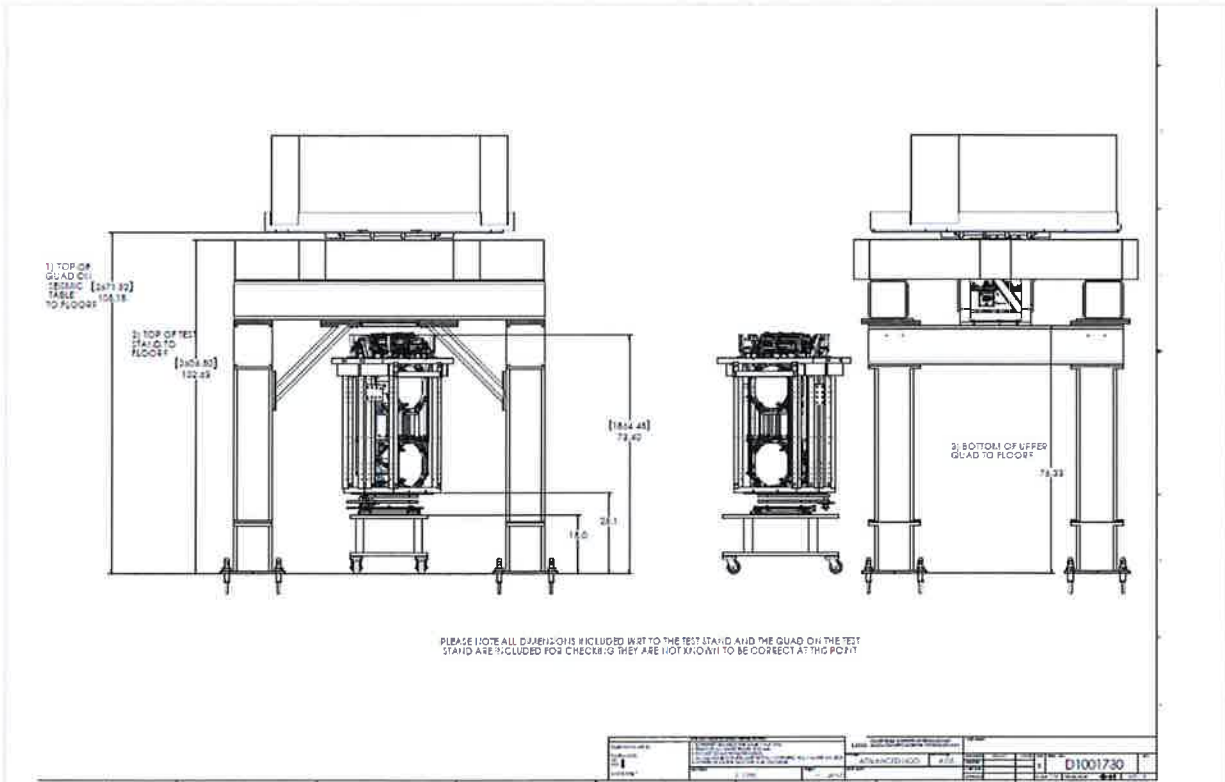

Figure 6 Sketch of the Test Stand with respect to the FMP tooling. Refer to D1001730: Sketch of Test Stand with respect to the FMP cartridge tooling

4.1 Install BSC-ISI onto the test stand

- Install BSC-ISI on test stand using Lift Hook Receiver assy (D1000744). Orient in the same direction as it will be in LBSC3 chamber (defined on pages 1 & 4 in G1000125).
Note: Install team report that this step is done by common knowledge based on previous experience.
- Remove the Lift Hook Receiver assy.

Completed, approved, checked by: *Jeremy Bied*

Date: *1-29-13*

Comments *Been on Test Stand for a few months.*



LBSC3

4.2 Prerequisites for Cartridge Integration

- The BSC- ISI stage 0 must be horizontal on BSC Test Stand #1. The Test Stand mount surfaces are leveled when built. Stage 0 is confirmed level to Test Stand when assembled.
- The corners of the test stand that interface with the BSC-ISI platform shall be used to establish a centerline and two offset lines with alignment monuments/references in the floor, as depicted in [D1200905](#). In case not clear, the monuments are already positioned on the floor.

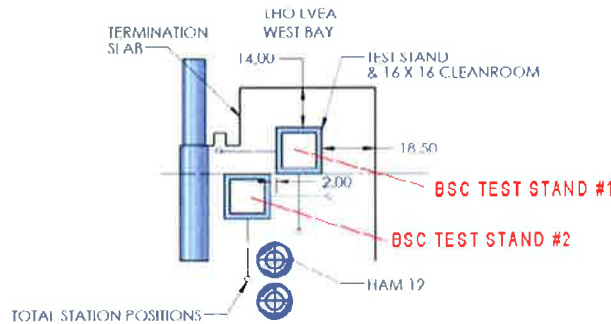

Figure 5. **Figure Name?**

Note that this illustration is for LHO but is similar to LLO ([D1200905](#) is for Livingston, but has no file). Where did this come from? Not from D1101596, the LHO version.

- Install appropriate cleanroom over test stand.
- All payload assemblies must be acceptance tested (to the extent possible and planned) prior to integration into the cartridge assembly.
Vague. Can we list specific tests so they can be checked off?

Completed, approved, checked by: *Seremy Birch*

Date: *1-29-13*

Comments *Completed in 2012*

4.3 Perform final BSC-ISI testing/characterization prior to payload integration

- Refer to [E1000487](#)

LBSC3

Celine RAMEY *Celine RAMEY*

Completed, approved, checked by: *Not done - waiting assembly validation*

Date: *01/29/12*

Comments

4.4 Install fiducial markers

- Install Fiducial Kit ([D1201150](#)) onto the ISI in their designated positions per [D1101271](#).

Completed, approved, checked by:

Date:

Comments

4.5 Attach alignment template for ITMX

- Attach one alignment template ([D1101050-11](#) or [D1101050-12](#)) per [D0900495](#) (page 2). The hole numbering system is defined in [D1101271](#).

Completed, approved, checked by: *Gary Taylor*

Date: *12/12*

Comments

4.6 Weigh suspension payloads

- Weigh the full ITM suspension per [T1100174](#). Record weight below.
- If the measured weight is greater than the mass budget in [E1000337](#) (363.49 kg), contact Systems immediately.

Table 3 SUS Payload Weight

Payload	Mass Budget (kg)	Measured Weight (kg)	Comments/caveats



LBSC3

ITM Suspension	363.51		
----------------	--------	--	--

Completed, approved, checked by: Gary T.

Date: 12/12

Comments

4.7 Install SEI balance masses

- Install the balance masses onto the optics table per [D1003064](#).

Note: Ideally, this is when the balance masses get added. However, it can also be done post install. If it is to be done post install (this should only be considered if parts are not available), care must be taken to correctly protect the quad during this work.

Completed, approved, checked by:

Date:

Comments

4.8 Install ITM and SUS payload

- Install all metal ITM onto ISI table on the test stand utilizing the tooling in [D1101674](#).
- Install dog clamps per [D0900495](#).
- Cable per [D1200059](#) and finish cabling per [D0900495](#).
- Install the full SUS payload per [D0900495](#), including:
 - Vibration absorbers
 - Sleeve
 - Wedges

Completed, approved, checked by: Gary Troylon

Date: 1/29/13

Comments

4.9 Phase 2a SUS Testing

- Rebalance ISI table.
- Suspend (un-lock) ITM per [T1100406](#).
- Perform phase 2a testing of ITM per [G1100693](#).

LBSC3

Completed, approved, checked by: 
Date: 30th Jan 2013
Comments

4.10 Detach ITMX Lower Structure (LS)

Using tooling from [D1101674](#):

- Lock ITM as per [T1100406](#).
- Split Lower Structure Main Chain/Reaction Chain.
- Move Main Chain into weld clean room.
- Remove masses.

Completed, approved, checked by: Gary Tidyler
Date: 12/12
Comments

4.11 Install Ring Heater

Using [G1100850](#):

- Install Upper Ring Heater Assy ([D1001838](#)).
- Install Lower Ring Heater Assy ([D1001895](#)).
- Install Ring Heater cables ([D1001517](#)).

Completed, approved, checked by: 
Date: 01/29/2012
Comments It's done

4.12 Install glass masses and weld fibers

- Install the new Main Chain loop as built per [D060516](#) (page 6).
- Position masses and weld fibers as per [T050213](#).
- Perform fiber tests per [T1100594](#).
- Suspend Reaction Chain in double suspension and align per [E1200888](#).

**LBSC3**

Completed, approved, checked by:

Date: 11/12

Comments

4.13 Re-attach Lower Structure

- Re-attach Main Chain/Reaction Chain Lower Structure.
- Remove First Contact on ITM AR and CP HR at connection of chains.
- Use FMP scissor lift ([D1101674](#)) to mate Lower Structure to Upper Structure.

Completed, approved, checked by:

Date: 11/12

Comments

4.14 Preparing the full quad

The following notes include information on lacing cables, suspending the suspension, coarsely aligning it, setting L-brackets, setting BOSEMs and damping.

- ✓ Lace cables per [D0900363](#) (page 5).

Note: While [D0900495](#) is the Quad for LBSC3, the detailed cabling views (the page 5 listed above) is only shown in the WBSC8 Quad i.e. [D0900363](#).

- ✓ Position L-brackets on BSC-ISI table as per page 3 of [D0900492](#). This is not an optional step and should be discussed with systems if any deviations arise.
- ✓ Suspend ITM per [T1100406](#).
- ✓ Coarsely align ITM, set BOSEMs and Damp.



LBSC3

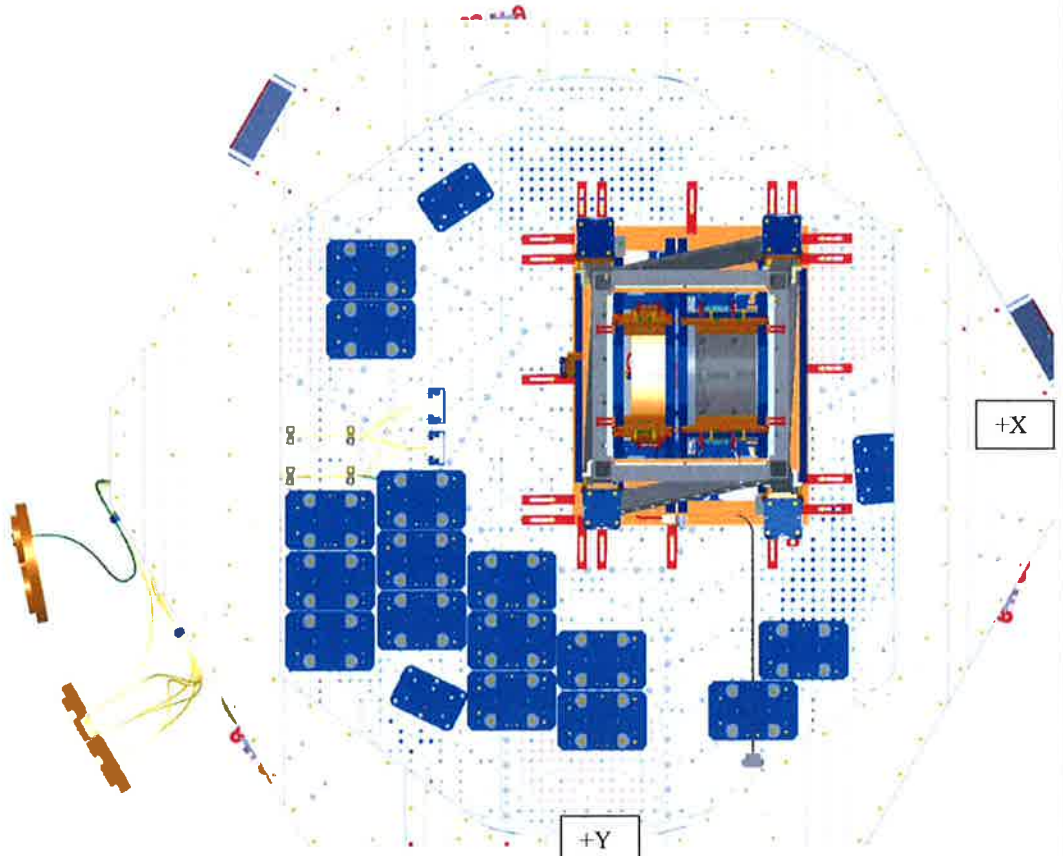

Figure 6 LBSC3 top-level assembly, bottom view looking up. Refer to D0900492: [aLIGO Systems, BSC3-L1 Top Level Chamber Assembly](#)

4.15 Perform fine IAS (align the Optics)

Relevant section from [E1200393](#) Initial Alignment Procedure -LBSC3 that is appropriate to alignment on the test stand. **Needs updating. Talk to Dennis.**

4.16 Phase 2b SUS testing

- Repeat Phase 2b testing [G1100693](#) and IAS section above if mechanical interferences found and fixed.

Completed, approved, checked by:	
Date:	1/12/13
Comments	



LBSC3

4.17 Re-install balance of SUS payload

- Sleeve
- Wedges
- Cross braces as per D0900495.

4.18 Post-Integration, Cartridge Testing

- SUS testing already in progress as per pervious section.
- Un-lock ISI.
- Perform Seismic Testing as per E1000487.

5 PROCEDURE FOR INSTALLATION INTO THE CHAMBER

The completed installation of all of the interferometer assemblies and components associated with the LBSC3 chamber is depicted in **Figure 9**.



LBSC3



Figure 7 LBSC1 top-level assembly with transparent chamber for clarity. Refer D0900492: [aLIGO Systems, BSC3-L1 Top Level Chamber Assembly](#)

LBSC3

Note: The wire tray support brackets will be different than shown in the drawing, but similar in overall concept/layout; Drawing to be revised.

- ✗ Install the Platforms A, B, C, & D ([D1001990](#)); and Module E ([D1002926](#)) around the chamber, per procedure [E1101051](#). Ensure fit, stability, and clearance with plumbing, gate valves, HEPI, etc.
- ✗ Install a BSC Chamber Cleanroom around the LBSC3 chamber and “rough” clean the chamber exterior and the region around the chamber. Install cleanroom lift mechanisms on cleanroom legs, ensure proper orientation, test operation, raise and lower to required heights.
- ✗ Stage for door and dome removal
 - C-3 covers
 - O-ring protectors
 - Bolts
 - O-ring Tools
 - Wrenches
 - Pallets
 - CPStat
 - Chamber-side cart (glove sorter, isopropanol, ConTec wipes)
- ✗ Confirm HEPI Lock-down set-screws are tight.
- ✗ Install and zero Dial Indicator Array on locked HEPI. This might best be delayed until in-air cabling is moved to chamber feed-throughs.
 Previous version had “install dial indicators on the BSC support tube ends” as a separate bullet. Same as above or separate? - NOW IS FINE
- ✗ Vent the Vertex and set the purge gas flowing per procedure [M1000360](#). Follow the Lockout-Tagout procedure [M990190](#).
 Vague. Ex: Section 3.2 Shutdown of Machine(s)/Equipment- ... shall shutdown equipment in a manner that is considered a normal operating procedure as defined by the equipment manufacturer. - OKAY
 E1200344’s section 4.1.6 said “vent vacuum section per [M1000369](#).” Wrong doc. - OKAY
- ✗ Break bolts on dome and doors.
- ✗ Perform first cleaning of chamber and garbing/staging cleanrooms (upper and lower) with special attention to E-module as per [E0900047](#).
- ✗ Install regular soft roof.
- ✗ Perform second cleaning per [E0900047](#).
- ✗ Install the BSC Chamber Flooring ([D961115](#)) in accordance with the orientation noted in [D1101429](#).
- ✗ Remove the BSC Dome per [E1101162](#) along with regular Soft Roof
- ✗ Install BSC dome tall C-3 cover on the chamber top and a C-3 SEI Soft Roof on the chamber cleanroom.

LBSC3

Install the Walking Plates ([D1002410](#), without railings). Since the walking plates attach to the chamber flange, our usual attachment of the C-3 cover will be thwarted. Secure the cover to the Walking Plates or Railing Kick Plates with Spring Clips.

Install Alignment Pins [D1102282](#) in BSC Support Tubes. Place the pins in the Support Tubes. *NOT USED* Keep in mind the pins will be obscured from view by the Cartridge (Suspensions). Position appropriately for best visibility.

Note: Bolts also work for this job and were used on LBSC1 at LLO.

Remove Work Platform Handrails if in place. *(No Need; we can't lower the clean room that low)*

Note: These do not always get removed at this stage. The minimum height may allow you to leave them in place. If they are being left in place this should be carefully considered before lowering the cleanroom.

Lower Cleanroom to minimum height.

Remove the LBSC3 Chamber Door per procedure [M1100068](#).

Inspect chamber and vacuum if needed. *Inspect For what?*

Install the **field cabling** from the electrical feed-throughs to the electronics racks, per **D#s?**

Note: The field cabling can be installed later, but must be done after the cable trays are in place, yet before the cartridge is installed.

Talk to Rich A./Eddie.

Not Needed at this time
 Install the viewports listed in Table 4 per procedures [E1100484](#) and [M990173](#)

Note: The viewports can be installed later in the sequence.

Table 4. List of LBSC3 Viewports from [T1100292](#)

Chamber	Viewport	Function	Description	Viewport P/N	Source
BSC3	C0G3	CO2-LASER	ITMX	TCS	CUSTOM
BSC3	G1	VIDEO	ITMX-CP	5.4 DIA VP800/450009	CATALOG
BSC3	G11	ILLUMINATION		5.4 DIA VP800/450009	iLIGO

Listed viewports for BSC3 only. There are additional items under the chamber column (ex: A-1A) that I don't know where to place. Need to check nothing has been left off the list.

Use two install docs simultaneously?

Calum will check 11/05. – LET's DISCUSS

Insure that the support tubes are level (to within 0.4 mrad) with a precision bubble level and HEPI static adjustment (per procedure [E040011](#))

Transport the Arm Cavity Baffle ([D1200580](#)) subassemblies, and associated installation equipment, into the manifold spool adjacent to LBSC3, per procedure [E1100810](#).



LBSC3

Does part about manifold spool apply to LBSC3 or just LBSC1? - YES

Completed, approved, checked by:

Date:

Comments

?

5.3 Prepare Cartridge Assembly for Installation into the Chamber

- Lock down the ITM per [T1100406](#).
- Install tooling/guards to protect the optics (ex: “lens caps”) per [D0901346](#).
- Place optics on their mechanical/earthquake stops per [D0900495](#).
- Lock all six lockers between Stage 0 and Stages 1 & 2. Lock Stage 1 corners 1, 2, then 3 in sequence; then lock Stage 2 corners 1, 2, and 3. Turn locker out until the faces almost touch (do not make tight). Endeavor to not move the suspended stage being locked while turning the Locker wheel.
- Disconnect cables that will connect to the vacuum flange. Temporarily coil and tie cables down to the BSC-ISI assembly with Class B Aluminum strips or cable ties. Do not remove cables.
- Check that cabling and all cable connectors/brackets are secure.
- Remove racks, cables, feed-throughs that will be in the way.
- Remove Keel Masses (and Viton pads) from top of BSC-ISI. Note location for re-assembly in the chamber.

Note – If other masses were used as temporary Keel Masses (e.g. old passive stack masses) these should also be removed at this point.

- Check all horizontal surfaces of the ISI/Test Stand/SUS for any loose hardware or tools. Document inspection with photos.
- Attach the (3) Lift Hook Receivers ([D1000753](#)) on the ISI Keel-plate, if not already installed (see [D1000756](#)). Torque 3/8”-16x2” Bumax-88 bolts to 15 ft-lb per load analysis [E1101017](#).
- Cover ISI with BSC-ISI cover.
- Wrap each suspension in appropriate C3 fabric bags.
- Remove nuts securing ISI to test stand.

LBSC3

Completed, approved, checked by: JB

Date: 2-6-13

Comments

5.4 Prepare LVEA

- Clear cabling on the floor, etc. to allow cleanroom to move.
- Set 3pt-lifter bale to predicted cartridge balance point. Then setup counter balance on lifter to keep lifter level when lifted.

Completed, approved, checked by: JB

Date: 2-6-13

Comments

5.5 Install the Cartridge Assembly into the Chamber

P In addition to this document E1200634 ensure that all personnel involved have read and understood

- the general completed cartridge installation procedure ([E1200344](#)),
- the specifics of the LBSC3 cartridge installation (CG location, flight path, close approach regions, etc. in ([E1200927](#) – doc for LBSC1. Need LBSC3 equivalent), SAM B WORKING 11/29/2012
- the unified generic hazard analysis ([E1200925](#)) and
- the critical lift plan ([E1200950](#) – doc for LBSC1. Need LBSC3 equivalent). SAM B WORKING 11/29/2012

P Using [E1200344](#), at least version v2, complete the following steps:

- Pre-flight (section 3.1)
- Test flight (section 3.2)
- Flight to chamber (section 3.2.10)
- Flight path at chamber (section 3.3)
- Flare, rollout, and tie-down (section 3.4)
- Debrief (section 3.5)

Now back to this document from [E1200344](#).

P Install the railings around the Walking Plates ([D1002410](#)) after landing the Cartridge onto the support tubes.

Note: LLO note that they have never used these. LLO should consider why and edit document to suit.

LBSC3

- X Check level of Stage 0 using a clean precision level. Adjust with HEPI if necessary until Stage 0 is level to within 0.4 mrad.

Note: The level of the BSC is checked with Optical Level on Optical Table with ISI locked.

- A Replace keel masses and Viton pads on top of Stage 2 per [E0900357](#).
- A Remove all temporary cable ties and connect all cabling to the appropriate electrical feed-throughs according to [D1003090](#).
 What about interface doc for the in-vac to air cables? Need cabling doc too.
Eddie S working the Nov 2012 – for now go to flange layout i.e. LIGO-D1003090: Flange Layout – L1 Beam Splitter Chamber 3 (BSC3) ITMX

A At this point any missing optical table masses should be installed.

A Unlock the ISI stages.

- Run TFs to ensure suspension is free from mechanical rubbing prior to IAS alignment below. If major alignment of the suspension is required in subsequent IAS steps, rechecking for mechanical rubbing via TFs may be needed.
- Remove the protective and lens cap for the ITM [D1100052](#).
- Unlock the ITM suspension per [T1100406](#).

Completed, approved, checked by:

Date:

Comments



LBSC3

5.6 Align the Cartridge Assembly

- Remove the spool between WCP1 and the manifold tube per procedure [E000121](#). **Correct? – I believe so, YES now it is.**
- Set up the Initial Alignment System (IAS) equipment in the region of the spool per procedure [E1200640](#).
**Needs updating, call out pages for large docs.
To do, leave for now. CIT 10/12. – DC asked to contribute 11/26/2012**
- Follow alignment procedure [E1200393](#) to align the Cartridge within the Chamber.
- Set SUS BOSEMs for buoyancy.
- Remove any installed IAS tooling (long survey rods, corner cube mounts, etc.)
- Remove vibration absorber locker pins.
- Close the Ring Heater.
- Protect and bag Quad.

Completed, approved, checked by:

Date:

Comments

5.7 Install the Arm Cavity Baffle

- Lock down the BSC-ISI stages.
- Lock down the ITM per [T1100406](#)
- Install the Arm Cavity Baffle per [E1100810](#)
- Ensure the ACB transport lock has been removed.
- Test per [E1000892](#).
Doc needs serious work. - NOTED

Completed, approved, checked by:

Date:

Comments



LBSC3

5.8 Install the TCS CO₂P Steering Mirror 1 Assembly

- Lock down the BSC-ISI stages – **already locked down.** – IF NOT ALREADY LOCKED
- Lock down the ITM per [T1100406](#) – **already locked down.** – IF NOT ALREADY LOCKED
- Install protective shields on the ITM suspension [D1100052](#).
- Install the TCS CO₂ Steering Mirror 1 Assembly per [D1101013](#).

Completed, approved, checked by:

Date:

Comments

5.9 Final Operations

- Remove First Contact™ from viewports and inspect.
- Remove locking pins from vibration absorbers [D1002424](#).
- Remove all tools (Check all horizontal surfaces high and low!)
- Check that flooring bolts are tight (they get kicked loose sometimes while walking around)
- Remove Class B shielding and lens cap [D1100052](#).
- Unlock all suspensions per [T1100406](#). (apart from those needed for First Contact application or removal)
- Set EQ stop gaps to appropriate settings and lock down all EQ stop nuts.
- (If still present, refer to [LIGO-T1200321-v6](#)) Remove First Contact™ from ITM (HR) and CP (S2 AR) per [E1000079](#) (pg 5-6). Remember to use ion gun.
- Inspect optical surfaces with a bright flashlight.
- If Frist Contact not present and if required (again refer to [LIGO-T1200321-v6](#)), clean the optics with First Contact™ per procedure [E1000079](#)

Special note - Per [T1200321](#) (pages 4, 5, 8):

- ITM (HR) = Level 1
- CP (S2 AR) = Level 2

After the final clean and pull of the first contact, if there is more work to be done before closing the chamber, then re-apply First Contact™ after:

- 3 days in air = Level 1



LBSC3

- 1 week in air = Level 2

These timeframes are flexible depending on the work that needs to be done. If heavy install work has to be carried out or planned work is expected to take more than 3 weeks, please contact COC (GariLynn Billingsley or Margot Phelps).

- Complete un-lock of suspensions (Set EQ stop gaps to appropriate settings and lock down all EQ stop nuts.)
- Remove any PFA fixturing/optic bumpers
- Ensure that the Arm Cavity Baffle transport lock ([E1100810](#)) is removed.
- Check for cleanliness: vacuum and wipe down as required
- Check again and remove all tools (Check all horizontal surfaces high and low!)
- Install witness plates
- Take pictures
- Perform final SUS Phase 3a testing per [G1100693](#).
- Perform SEI testing III testing per [E1000488](#).
- Close doors/dome.
- Pump down.
- Perform more testing (SUS Phase 3b G1100693, SEI...)

Completed, approved, checked by:

Date:

Comments



LBSC3

6 TESTING

Prior to pumping the Y-manifold down to vacuum all active components must pass stand-alone, in-situ testing to see that the assembly behaves properly after the installation procedure and with the field-installed cabling, etc (i.e. phase 3 testing per [M1000211](#)):

M1000211 is more an explanation of when testing happens & how to write-up, not a step by step guide.

- [E1000488](#), “BSC-ISI Testing Procedure, Phase III: Control Commissioning”
- [G1100693](#), “Ideal Order/Contents of aLIGO QUAD Testing / Commissioning”

AOS or TCS have testing requirements? – YES and TEAMS (LISA and MINDY) know they have to provide. CIT To re-ask 11/27/2102

Completed, approved, checked by:

Date:

Comments

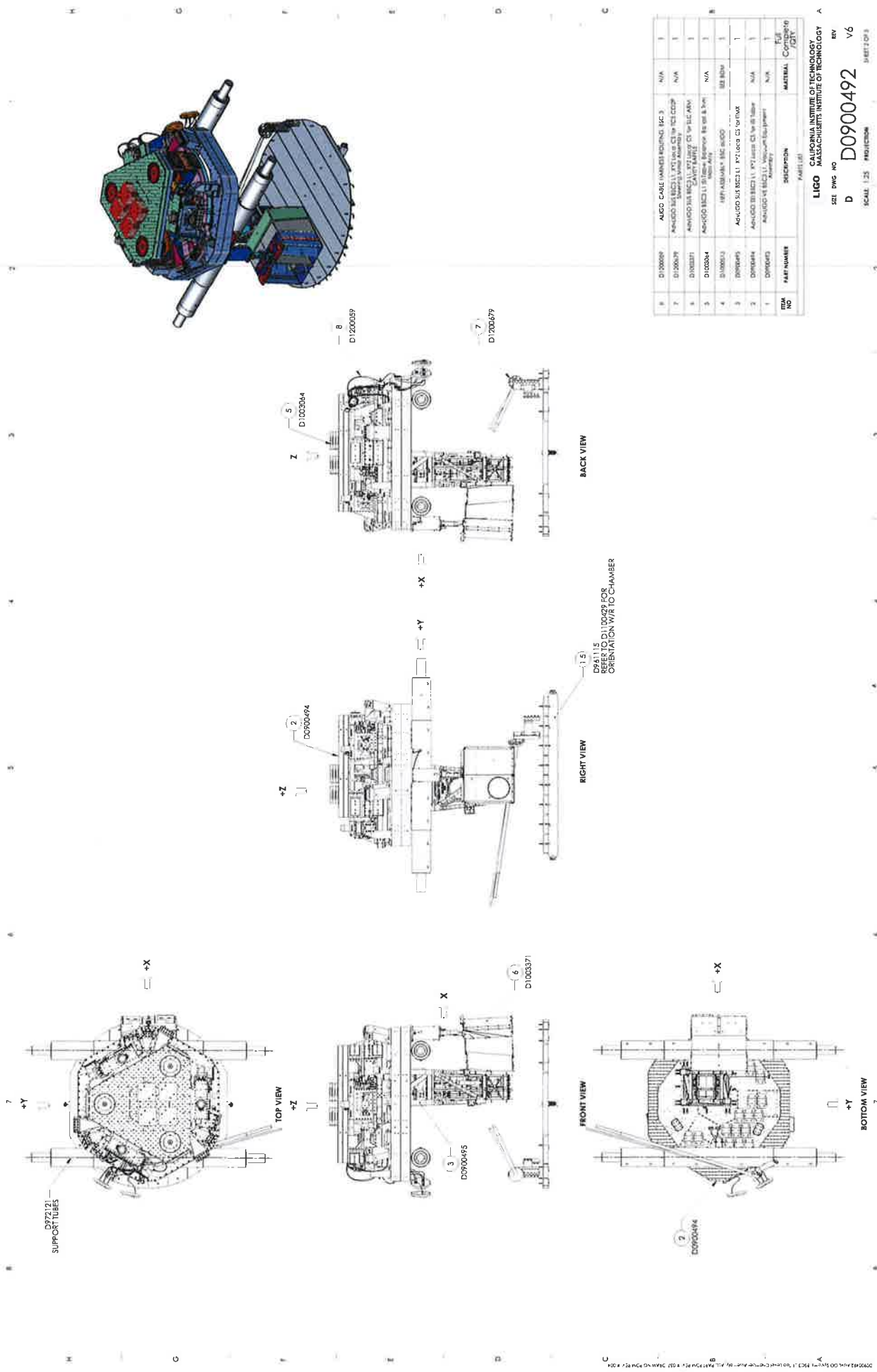

ITEM NO	PART NUMBER	DESCRIPTION	MATERIAL	QTY
6	D100029	ALGO CABLE HARNESS BOUND SEC 3	N/A	1
7	D100049	ALGO CABLE HARNESS BOUND SEC 3	N/A	1
8	D100337	ALGO CABLE HARNESS BOUND SEC 3	N/A	1
9	D100334	ALGO CABLE HARNESS BOUND SEC 3	N/A	1
10	D100335	ALGO CABLE HARNESS BOUND SEC 3	N/A	1
11	D100336	ALGO CABLE HARNESS BOUND SEC 3	N/A	1
12	D100337	ALGO CABLE HARNESS BOUND SEC 3	N/A	1
13	D100338	ALGO CABLE HARNESS BOUND SEC 3	N/A	1
14	D100339	ALGO CABLE HARNESS BOUND SEC 3	N/A	1
15	D100340	ALGO CABLE HARNESS BOUND SEC 3	N/A	1
16	D100341	ALGO CABLE HARNESS BOUND SEC 3	N/A	1
17	D100342	ALGO CABLE HARNESS BOUND SEC 3	N/A	1
18	D100343	ALGO CABLE HARNESS BOUND SEC 3	N/A	1
19	D100344	ALGO CABLE HARNESS BOUND SEC 3	N/A	1
20	D100345	ALGO CABLE HARNESS BOUND SEC 3	N/A	1
21	D100346	ALGO CABLE HARNESS BOUND SEC 3	N/A	1
22	D100347	ALGO CABLE HARNESS BOUND SEC 3	N/A	1
23	D100348	ALGO CABLE HARNESS BOUND SEC 3	N/A	1
24	D100349	ALGO CABLE HARNESS BOUND SEC 3	N/A	1
25	D100350	ALGO CABLE HARNESS BOUND SEC 3	N/A	1
26	D100351	ALGO CABLE HARNESS BOUND SEC 3	N/A	1
27	D100352	ALGO CABLE HARNESS BOUND SEC 3	N/A	1
28	D100353	ALGO CABLE HARNESS BOUND SEC 3	N/A	1
29	D100354	ALGO CABLE HARNESS BOUND SEC 3	N/A	1
30	D100355	ALGO CABLE HARNESS BOUND SEC 3	N/A	1
31	D100356	ALGO CABLE HARNESS BOUND SEC 3	N/A	1
32	D100357	ALGO CABLE HARNESS BOUND SEC 3	N/A	1
33	D100358	ALGO CABLE HARNESS BOUND SEC 3	N/A	1
34	D100359	ALGO CABLE HARNESS BOUND SEC 3	N/A	1
35	D100360	ALGO CABLE HARNESS BOUND SEC 3	N/A	1
36	D100361	ALGO CABLE HARNESS BOUND SEC 3	N/A	1
37	D100362	ALGO CABLE HARNESS BOUND SEC 3	N/A	1
38	D100363	ALGO CABLE HARNESS BOUND SEC 3	N/A	1
39	D100364	ALGO CABLE HARNESS BOUND SEC 3	N/A	1
40	D100365	ALGO CABLE HARNESS BOUND SEC 3	N/A	1
41	D100366	ALGO CABLE HARNESS BOUND SEC 3	N/A	1
42	D100367	ALGO CABLE HARNESS BOUND SEC 3	N/A	1
43	D100368	ALGO CABLE HARNESS BOUND SEC 3	N/A	1
44	D100369	ALGO CABLE HARNESS BOUND SEC 3	N/A	1
45	D100370	ALGO CABLE HARNESS BOUND SEC 3	N/A	1
46	D100371	ALGO CABLE HARNESS BOUND SEC 3	N/A	1
47	D100372	ALGO CABLE HARNESS BOUND SEC 3	N/A	1
48	D100373	ALGO CABLE HARNESS BOUND SEC 3	N/A	1
49	D100374	ALGO CABLE HARNESS BOUND SEC 3	N/A	1
50	D100375	ALGO CABLE HARNESS BOUND SEC 3	N/A	1
51	D100376	ALGO CABLE HARNESS BOUND SEC 3	N/A	1
52	D100377	ALGO CABLE HARNESS BOUND SEC 3	N/A	1
53	D100378	ALGO CABLE HARNESS BOUND SEC 3	N/A	1
54	D100379	ALGO CABLE HARNESS BOUND SEC 3	N/A	1
55	D100380	ALGO CABLE HARNESS BOUND SEC 3	N/A	1
56	D100381	ALGO CABLE HARNESS BOUND SEC 3	N/A	1
57	D100382	ALGO CABLE HARNESS BOUND SEC 3	N/A	1
58	D100383	ALGO CABLE HARNESS BOUND SEC 3	N/A	1
59	D100384	ALGO CABLE HARNESS BOUND SEC 3	N/A	1
60	D100385	ALGO CABLE HARNESS BOUND SEC 3	N/A	1
61	D100386	ALGO CABLE HARNESS BOUND SEC 3	N/A	1
62	D100387	ALGO CABLE HARNESS BOUND SEC 3	N/A	1
63	D100388	ALGO CABLE HARNESS BOUND SEC 3	N/A	1
64	D100389	ALGO CABLE HARNESS BOUND SEC 3	N/A	1
65	D100390	ALGO CABLE HARNESS BOUND SEC 3	N/A	1
66	D100391	ALGO CABLE HARNESS BOUND SEC 3	N/A	1
67	D100392	ALGO CABLE HARNESS BOUND SEC 3	N/A	1
68	D100393	ALGO CABLE HARNESS BOUND SEC 3	N/A	1
69	D100394	ALGO CABLE HARNESS BOUND SEC 3	N/A	1
70	D100395	ALGO CABLE HARNESS BOUND SEC 3	N/A	1
71	D100396	ALGO CABLE HARNESS BOUND SEC 3	N/A	1
72	D100397	ALGO CABLE HARNESS BOUND SEC 3	N/A	1
73	D100398	ALGO CABLE HARNESS BOUND SEC 3	N/A	1
74	D100399	ALGO CABLE HARNESS BOUND SEC 3	N/A	1
75	D100400	ALGO CABLE HARNESS BOUND SEC 3	N/A	1
76	D100401	ALGO CABLE HARNESS BOUND SEC 3	N/A	1
77	D100402	ALGO CABLE HARNESS BOUND SEC 3	N/A	1
78	D100403	ALGO CABLE HARNESS BOUND SEC 3	N/A	1
79	D100404	ALGO CABLE HARNESS BOUND SEC 3	N/A	1
80	D100405	ALGO CABLE HARNESS BOUND SEC 3	N/A	1
81	D100406	ALGO CABLE HARNESS BOUND SEC 3	N/A	1
82	D100407	ALGO CABLE HARNESS BOUND SEC 3	N/A	1
83	D100408	ALGO CABLE HARNESS BOUND SEC 3	N/A	1
84	D100409	ALGO CABLE HARNESS BOUND SEC 3	N/A	1
85	D100410	ALGO CABLE HARNESS BOUND SEC 3	N/A	1
86	D100411	ALGO CABLE HARNESS BOUND SEC 3	N/A	1
87	D100412	ALGO CABLE HARNESS BOUND SEC 3	N/A	1
88	D100413	ALGO CABLE HARNESS BOUND SEC 3	N/A	1
89	D100414	ALGO CABLE HARNESS BOUND SEC 3	N/A	1
90	D100415	ALGO CABLE HARNESS BOUND SEC 3	N/A	1
91	D100416	ALGO CABLE HARNESS BOUND SEC 3	N/A	1
92	D100417	ALGO CABLE HARNESS BOUND SEC 3	N/A	1
93	D100418	ALGO CABLE HARNESS BOUND SEC 3	N/A	1
94	D100419	ALGO CABLE HARNESS BOUND SEC 3	N/A	1
95	D100420	ALGO CABLE HARNESS BOUND SEC 3	N/A	1
96	D100421	ALGO CABLE HARNESS BOUND SEC 3	N/A	1
97	D100422	ALGO CABLE HARNESS BOUND SEC 3	N/A	1
98	D100423	ALGO CABLE HARNESS BOUND SEC 3	N/A	1
99	D100424	ALGO CABLE HARNESS BOUND SEC 3	N/A	1
100	D100425	ALGO CABLE HARNESS BOUND SEC 3	N/A	1

LIGO CALIFORNIA INSTITUTE OF TECHNOLOGY
 MASSACHUSETTS INSTITUTE OF TECHNOLOGY
 SEE DWG NO D0900492
 D D0900492
 SCALE 1:25 PROVISIONAL
 REV V6
 SHEET 1 OF 1

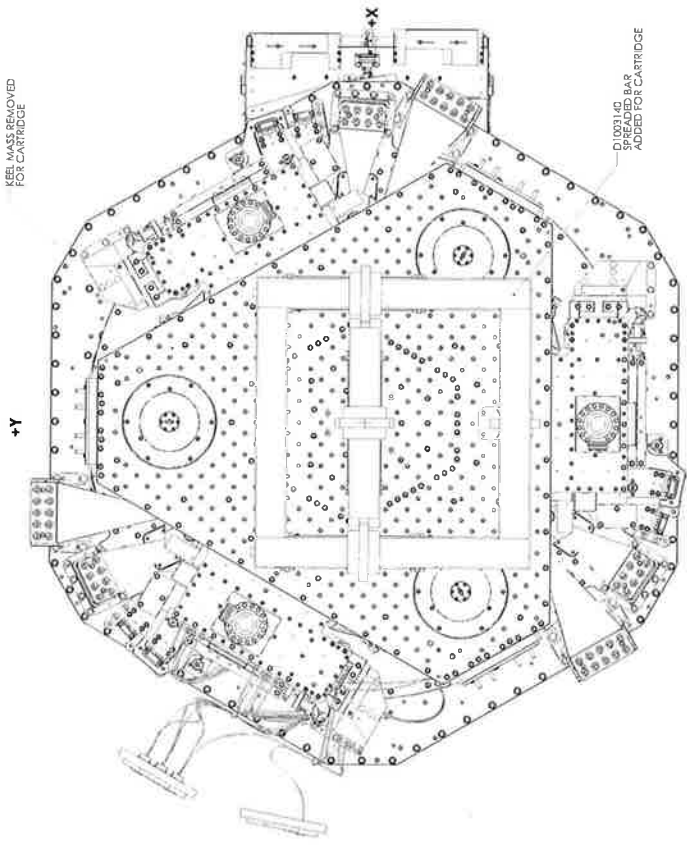

**TOP VIEW
(LOOKING DOWN)
CARTRIDGE ASSEMBLY CONFIGURATION
KEEL MASS REMOVED**

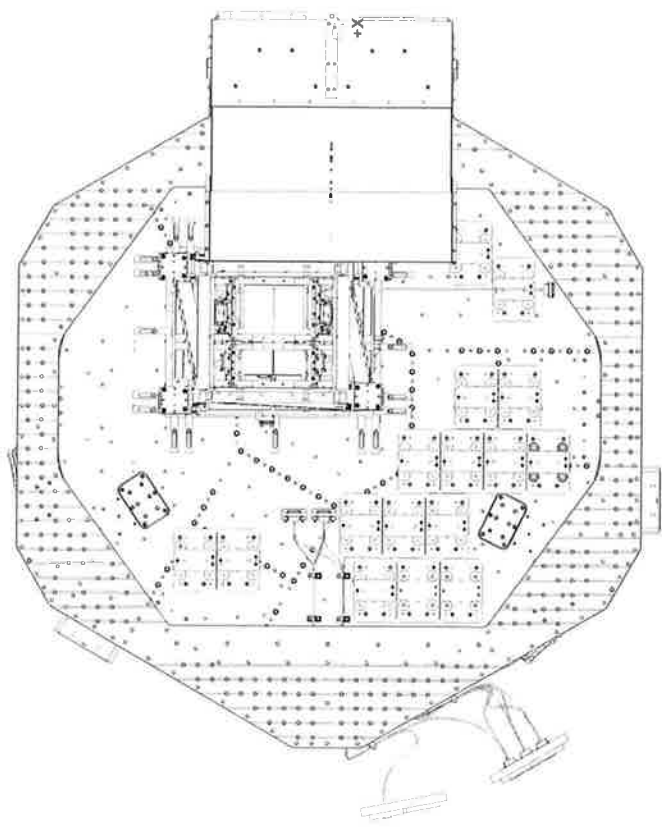

**BOTTOM VIEW
(LOOKING UP)**

"BSC 3"

"TO DO"

- ~~⊗~~ Remove masses from keel
- ~~⊗~~ Install NUTS on masses
- ~~⊗~~ Disconnect SUS cables
- ~~⊗~~ Stage support tube hardware
- ~~⊗~~ Stage in chamber tools
- ~~⊗~~ Lower Clean room ^{Apollo}
+ Hook up Actuators
- ~~⊗~~ Dial Indicators install ^{Apollo}
- ~~⊗~~ Wipe down lift fixture
- ~~⊗~~ Install BSC DOME + all cover + Stage Clean room top face AM.
- ~~⊗~~ Tooling bins

- ~~⊗~~ Stage Covers
 - CRANE Debris
 - Caeridge
 - ISI
 - BSC Dome

~~⊗~~ Check HEPT is locked down ^{Apollo}

~~⊗~~ Stage Loadcell

DMATT Particle counts + inspect chamber.

"TO DO in the AM"

- ~~⊗~~ Test lift (Recover Weight)
- ~~⊗~~ Meeting
- Install 2nd Soft cover on Clean Room
- TAG lines X4 on Caeridge.

TEAM

Jeany Lead
GARY

~~WICK~~ CRANE
~~DANNY~~

SEI team Test Lift
(move Clean Room Back)

~~DANNY~~ / Apollo TAG Lines

Apollo (Clean Room)
Jeany (Replace transition plate also)

Apollo Mike V ~~DANNY~~ Upper Spotters

Alexis / ~~MATT~~ Lower Spotters
Celine Support

~~DANNY~~ WICK Dhanos

8 7 6 5 4 3 2 1

NOTES CONTINUED:
 5. VENDOR REFERENCES ARE PROVIDED AS EXAMPLES OF PARTS MEETING ALL REQUIRED SPECIFICATIONS. EQUIVALENTS ARE ALWAYS ACCEPTABLE UNLESS OTHERWISE SPECIFIED.
 6. REFER TO LIGO E0900357 FOR ASSEMBLY AND LOADING PROCEDURE.

REV.	DATE	DCN #	DRAWING TREE #
v1	20 Apr. 2010	E1000152	E1000025
v2	19 SEPT 2011		

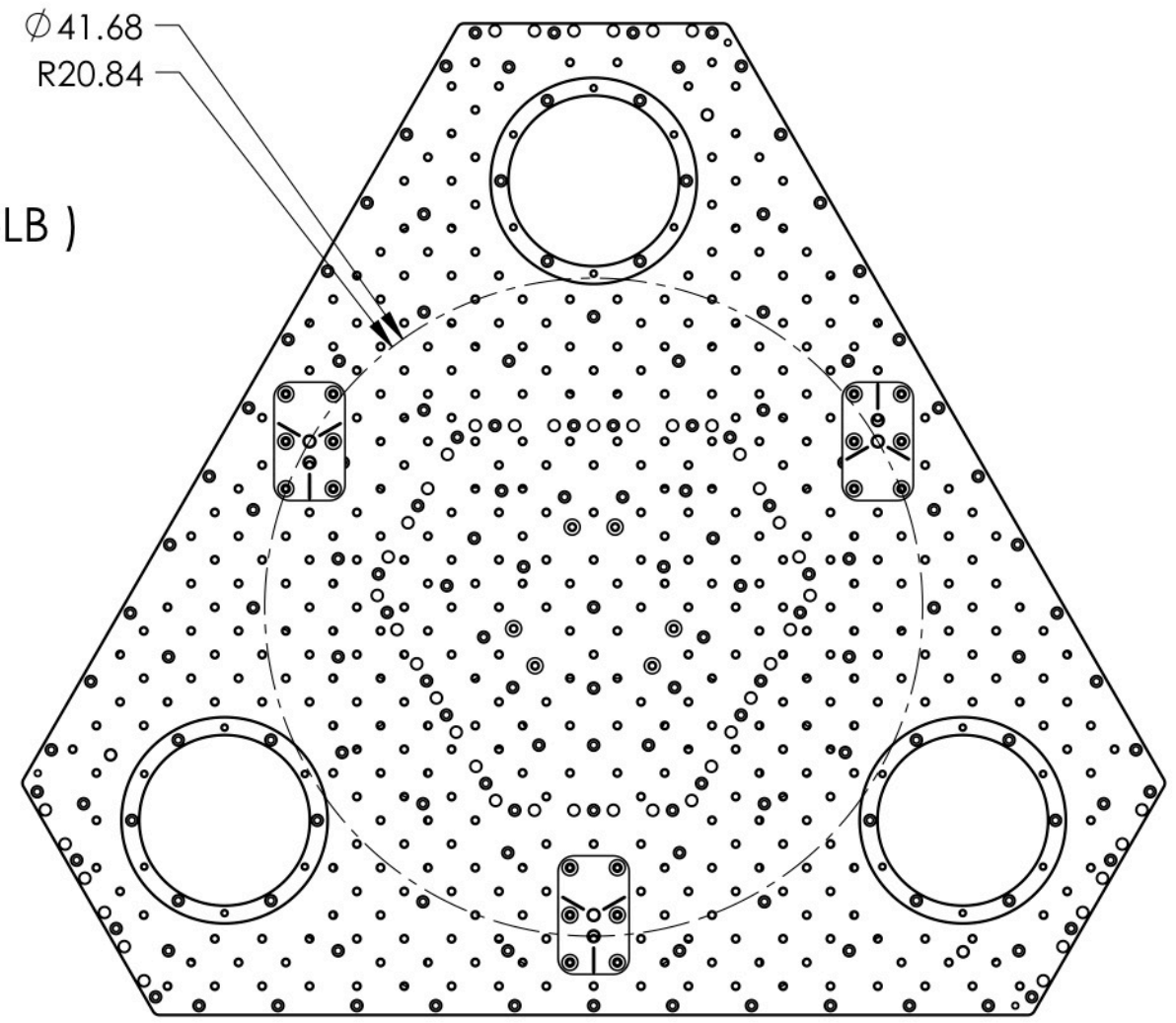
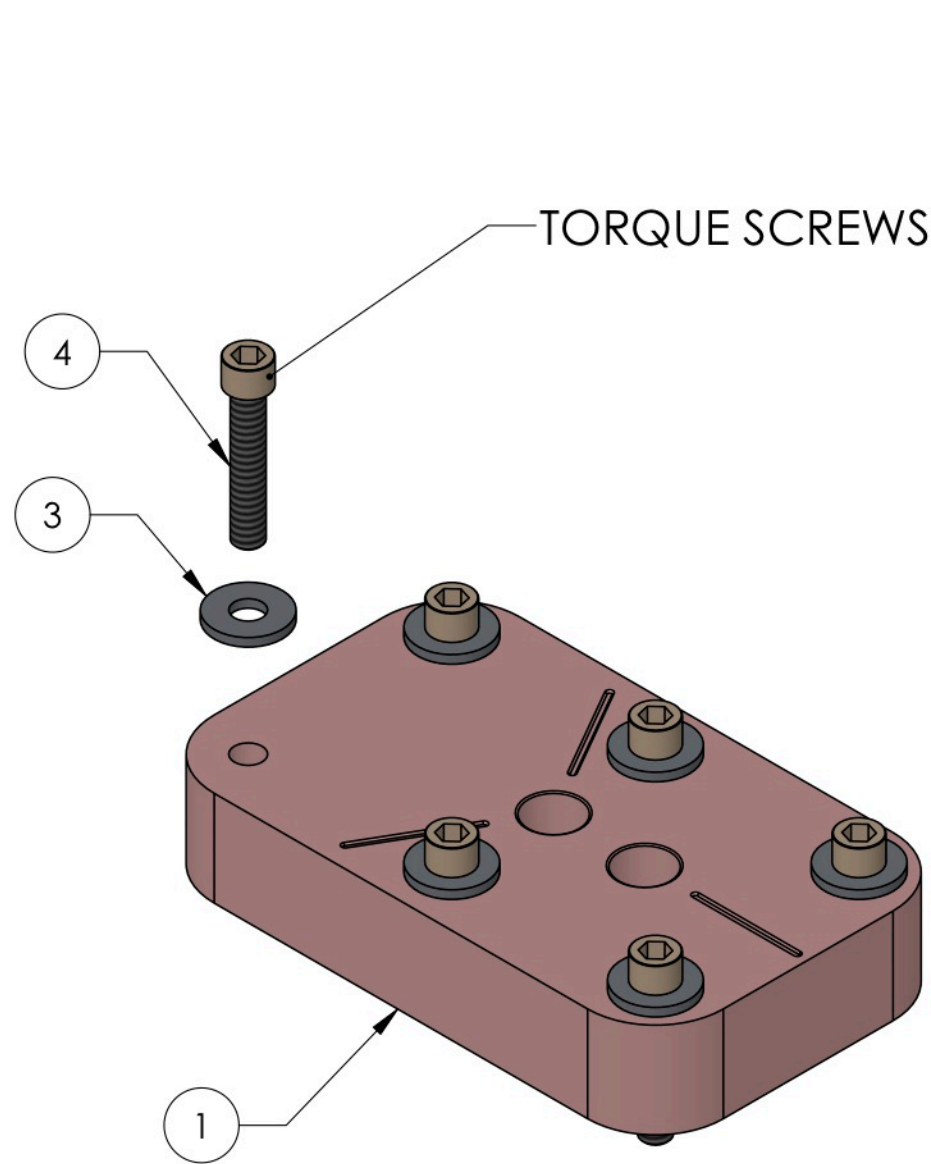

3X SETS OF LIFTHOOK RECEIVERS AND HARDWARE ARE NEEDED PER ISI

4	McMASTER_92488A302	SHCS, 3/8"-16 x 2.0" BUMAX-88 SST	BUMAX-88	6
3	MCMaster_98370A021	Flat Washer, 3/8"	18-8 SS	6
1	D1000753	BASE, SAFTEY, LIFT HOOK RECIEVER, aLIGO BSC ISI	304 SSTL	1
ITEM NO.	PART NUMBER	DESCRIPTION	MATERIAL	REQ

NOTES AND TOLERANCES: (UNLESS OTHERWISE SPECIFIED)

DIMENSIONS ARE IN INCHES
 TOLERANCES:
 .XX ± N/A
 .XXX ± N/A
 ANGULAR ± N/A*

1. INTERPRET DRAWING PER ASME Y14.5-1994.
 2. BREAK ALL EDGES AND CORNERS .03 X 45°.
 3. DO NOT SCALE FROM DRAWING.
 4. ALL MACHINING FLUIDS MUST BE FULLY SYNTHETIC, FULLY WATER SOLUBLE AND FREE OF SULFUR, SILICONE, AND CHLORINE.

MATERIAL N/A **FINISH** N/A μinch

SYSTEM ADVANCED LIGO **SUB-SYSTEM** SEI **NEXT ASSY** D0908211

LIGO CALIFORNIA INSTITUTE OF TECHNOLOGY
 MASSACHUSETTS INSTITUTE OF TECHNOLOGY

PART NAME SAFTEY, LIFT HOOK RECIEVER, aLIGO BSC ISI

DESIGNER	S.BARNUM	20 Apr. 2010	SIZE	DWG. NO.	REV.
DRAFTER	S.BARNUM	20 Apr. 2010	B	D1000756	v2
CHECKER	F.MATICHERD	20 Apr. 2010	SCALE:	1:2	PROJECTION:
APPROVAL	K.MASON	20 Apr. 2010	SHEET 1 OF 1		

D1000756 Safety, Lift Hook Receiver, BSC-ISI, aLIGO, PART PDM REV: X-008, DRAWING PDM REV: X-008

8 7 6 5 4 3 2 1