

LASER INTERFEROMETER GRAVITATIONAL WAVE OBSERVATORY
- LIGO -
CALIFORNIA INSTITUTE OF TECHNOLOGY
MASSACHUSETTS INSTITUTE OF TECHNOLOGY

Technical Note	LIGO-T1200410-v2	2013/03/02
aLIGO ISC Anti-symmetric Port: Beam Parameters and Optical Layout		
L. Barsotti		

California Institute of Technology
LIGO Project, MS 18-34
Pasadena, CA 91125
Phone (626) 395-2129
Fax (626) 304-9834
E-mail: info@ligo.caltech.edu

Massachusetts Institute of Technology
LIGO Project, Room NW17-161
Cambridge, MA 02139
Phone (617) 253-4824
Fax (617) 253-7014
E-mail: info@ligo.mit.edu

LIGO Hanford Observatory
Route 10, Mile Marker 2
Richland, WA 99352
Phone (509) 372-8106
Fax (509) 372-8137
E-mail: info@ligo.caltech.edu

LIGO Livingston Observatory
19100 LIGO Lane
Livingston, LA 70754
Phone (225) 686-3100
Fax (225) 686-7189
E-mail: info@ligo.caltech.edu

1 Introduction

This note summarizes the optical layout at the anti-symmetric port of the IFO, both in-vacuum (HAM6) and in the in-air table (ISCT6). The three in-vacuum beam paths are described:

- AS: sample of the main IFO beam, before reaching the OMC;
- OMCREFL: beam reflected from the OMC;
- OMCTRANS: beam transmitted through the OMC.

The same name, with a suffix “AIR”, is used for the in-air beams.

The design of the in-vacuum Gouy phase telescopes is summarized here [1], and how the detected signals are used in the length and angular control scheme is described in [2]

2 Beam leaving the IFO at the Anti-symmetric port

The profile of the beam leaving the IFO at the anti-symmetric port (AS), right after the Signal Recycling Mirror (SRM), is shown in figure 1. Its parameters are summarized in table 2, and they are used as input for designing the mode matching telescope to the OMC, and the Gouy phase telescopes for the AS WFSs (in vacuum and in air) and for the QPDs in reflection to the OMC.

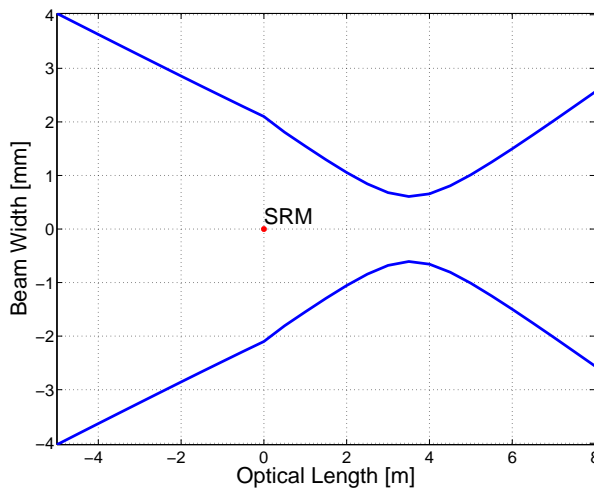

Parameter	Value
q	$-3.55 + 1.09i$ m
waistSize	6.06e-04 m
waistZ	-3.55 m
divergenceAngle	5.59e-04 rad
radiusOfCurvature	-3.88 m
beamWidth	0.0021 m
rayleighRange	1.0855 m

Figure 1: Profile of the beam leaving the IFO. Table 1: Parameters of the beam right after SRM.

3 HAM6 optical layout and beam profile

The optical layout of HAM6 is shown in figure 2. Refer to the most recent version of D1000342 for updated information. A description of each of the optical components is summarized in figure 3.

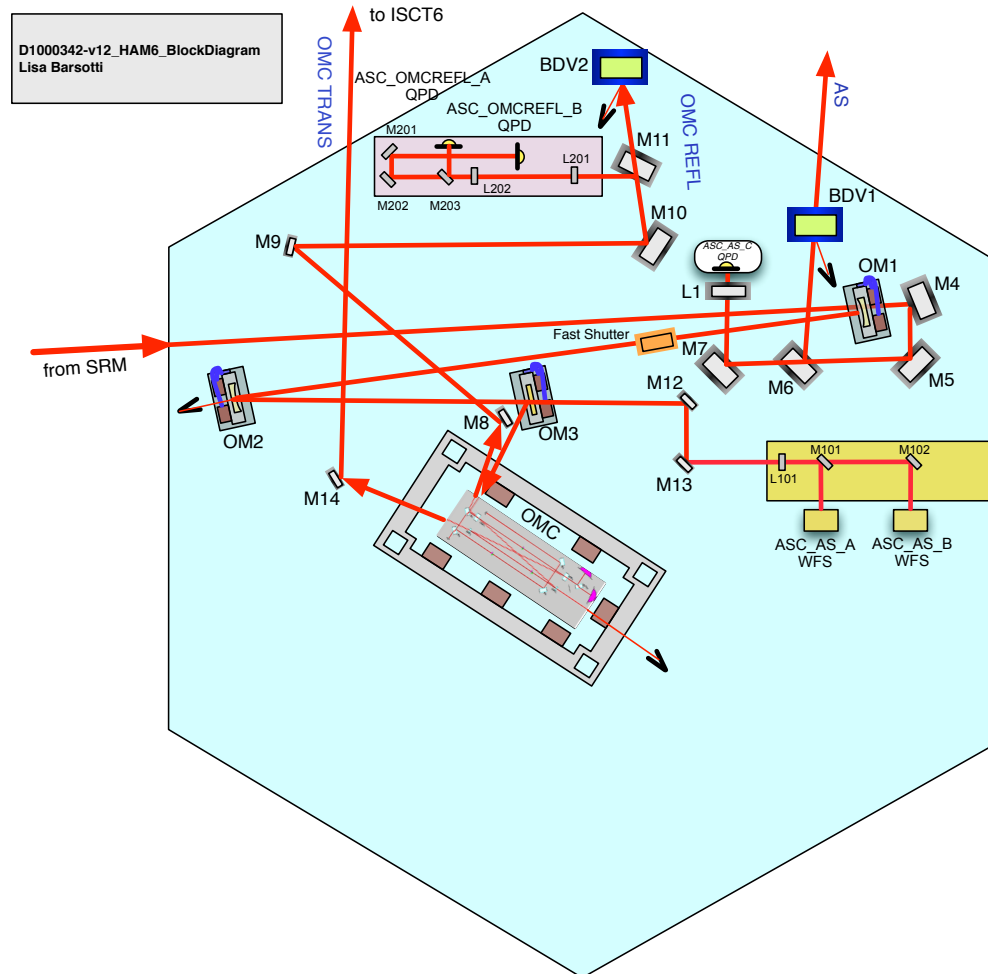

Figure 2: HAM6 optical layout. Refer to the most recent version of D1000342 for updated information.

ID	Size	Type	DCC	OptoMechanics
OM1	2"	+4.6m ROC	E1100056-02	TipTilt
OM2	2"	+1.7m ROC	E1100056-01	TipTilt
OM3	2"	BS99%1064	E1000457	TipTilt
M4	2"	HR1064	E1100048	2" kinematic mirror on table
M5	2"	HR1064	E1100048	2" kinematic mirror on table
M6	2"	BS50%1064	E1000671-02	2" kinematic mirror on table
M7	2"	HR1064	E1100048	2" pico motor mirror on table
M8	1"	HR1064	E1000595	1" mirror on table
M9	1"	HR1064	E1000595	1" pico motor mirror on table
M10	2"	HR1064	E1100048	2" pico motor mirror on table
M11	2"	BS50%1064	E1000671-02	2" kinematic mirror on table
M12	1"	HR1064	E1000595	1" kinematic mirror on table
M13	1"	HR1064	E1000595	1" kinematic mirror on table
M14	1"	HR1064	E1000595	1" kinematic mirror on table
M101	1"	BS50%1064	E1000671-01	1" pico motor mirror on sled
M102	1"	HR1064	E1000595	1" pico motor mirror on sled
L101	1"	f=+334mm	E1000845-03	1" fixed lens on sled
M201	1"	HR1064	E1000595	1" kinematic mirror on sled
M202	1"	HR1064	E1000595	1" kinematic mirror on sled
M203	1"	BS50%1064	E1000671-01	1" kinematic mirror on sled
L201	1"	f=+334mm	E1000845-03	1" fixed lens on sled
L202	1"	f=-334mm	E1000845-09	1" fixed lens on sled
L1	2"	f=+334mm	E1000845-10	2" fixed lens on table
BDV1	2"	HR1064	E1100048	Beam Diverter
BDV2	2"	HR1064	E1100048	Beam Diverter

Figure 3: List of optical components and opto-mechanics in HAM6. Refer to the most recent version of D1000342 for updated information.

3.1 AS path

Before reaching the OMC, samples of the main interferometer output beam (AS) are detected for length and alignment control.

After passing the beam reducing telescope, 1% of the main interferometer output signal is transmitted through OM3 to a set of 2 WFSs, placed 90° of Gouy phase apart. The AS beam profile is shown in figure 4, and the beam parameters are shown in table 3.1. Only one lens is used in this Gouy phase telescope:

- L101: 1" convergent lens, focal length = +0.334 m.

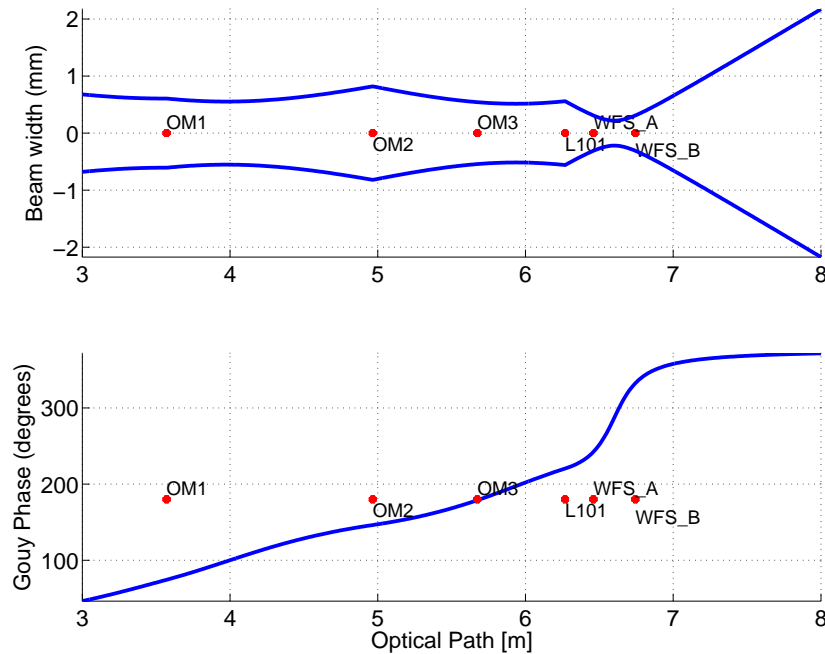

Figure 4: AS in-vacuum path.

3.1.1 OMC mode matching telescope

The curvature and position of the first two tip tilt mirrors in HAM6 (OM1 and OM2) are determined by Keita's baseline solution for mode matching the AS beam into the OMC [4]. The mode matching telescope is based on the designed parameters of the OMC [5].

Label	z [m]	Beam Width [mm]	Gouy Phase
SRM	0	2.0724	0.2°
OM1	3.571	0.61	74.4°
OM2	4.966	0.82	146.3°
OM3	5.674	0.54	178.9°
L101	6.279	0.56	220.5°
WFS A	6.46	0.31	242.4°
WFS B	6.743	0.31	332.4°

Table 2: Beam parameters in the in vacuum AS path.

3.2 OMCREFL path

A set of 2 in vacuum QPDs, placed 90° of Gouy phase apart, detect the beam reflected from the OMC. Two lenses are used for the Gouy phase telescope:

- L201: 1" convergent lens, focal length = +0.334 m;
- L202: 1" divergent lens, focal length = -0.334 m;

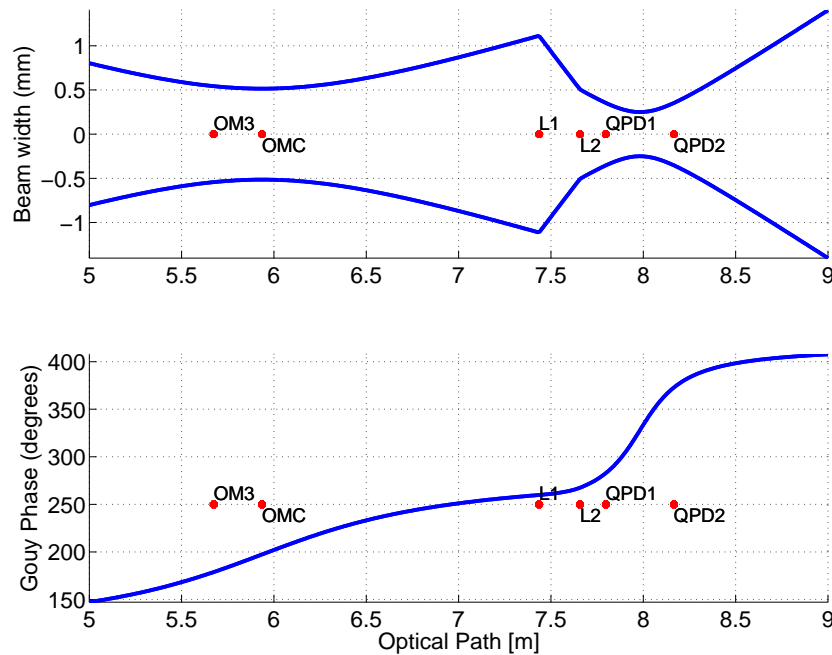

Figure 5: OMCREFL in vacuum path.

The OMCREFL beam profile is shown in figure 5, and the beam parameters are shown in table 3.2. A sample of the OMCREFL beam is also sent to the in-air table.

Label	z [m]	Beam Width [mm]	Gouy Phase
TT3	5.674	0.54	178.9°
OMC waist	5.936	0.51	197.4°
L201	7.436	1.11	259.9°
L202	7.658	0.51	267.6°
QPD_A	7.797	0.35	282.9°
QPD_B	8.166	0.35	372.9°

Table 3: Beam width on each component in the in vacuum OMCREFL path.

3.3 OMCTRANS path

The profile of the beam sampled in transmission to the OMC is described in figure 6. The OMC marker corresponds to the location of the OMC waist.

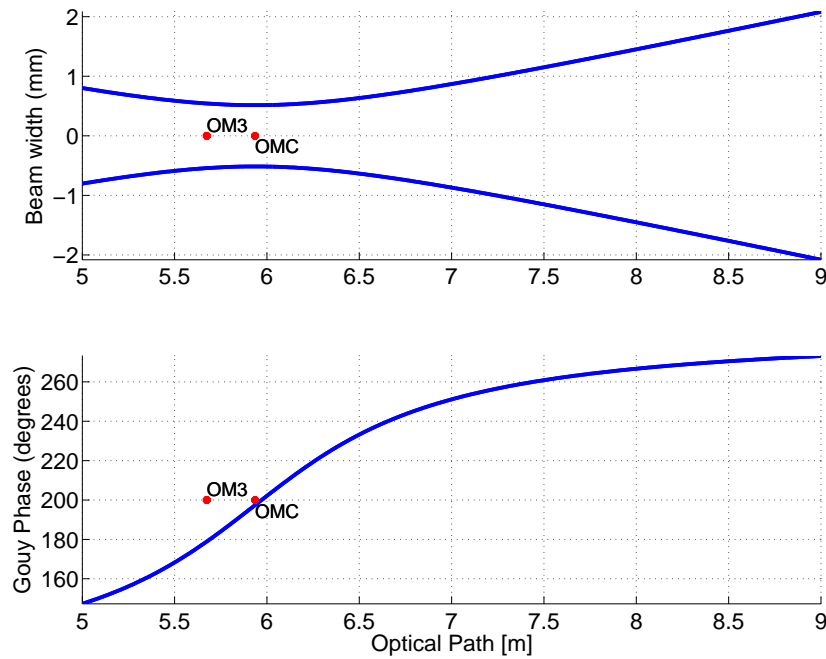

Figure 6: OMCTRANS in vacuum path.

4 ISCT6 optical layout and beam profile

An overview of the proposed ISCT6 layout is shown in figure 7.

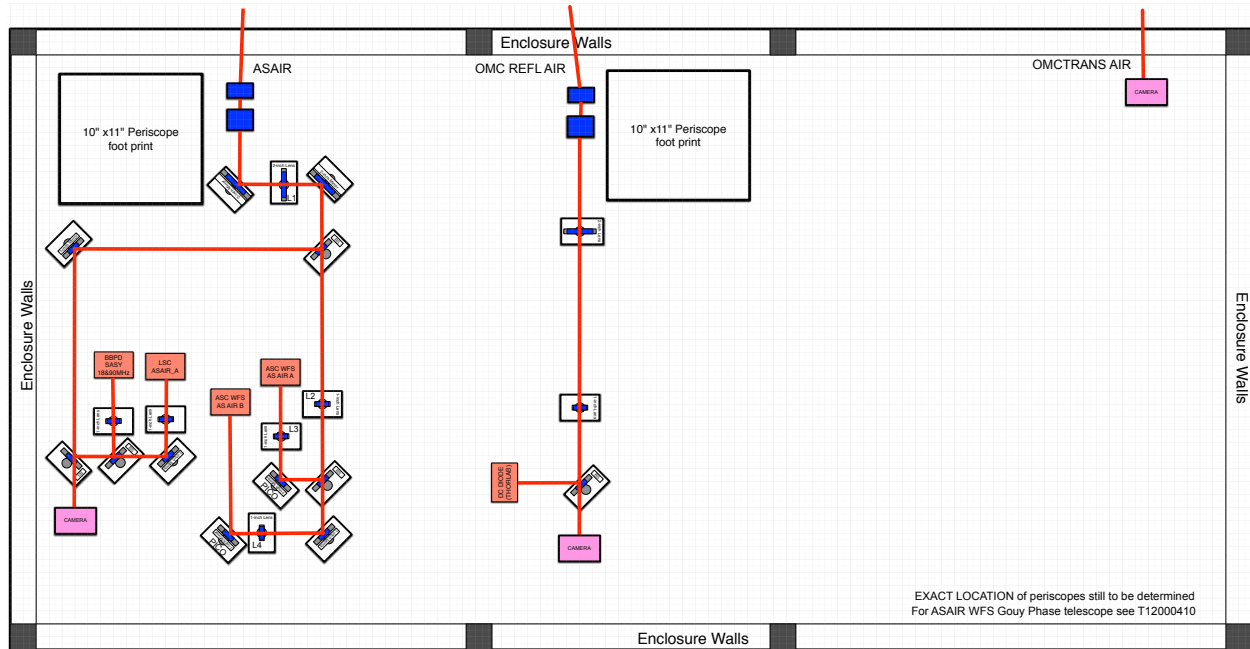

Figure 7: ISCT6 optical layout. Refer to the most recent version of D1201210 for updated information.

The AS, OMCREFL, and OMCTRANS are all routed to ISCT6. The ASAIR beam is detected by several diodes:

- 2 WFSs for alignment control;
- 1 LSC RFPD for length control;
- 1 Broad Band PD (BBPD) for detecting the sidebands power ($2f$ SASY signals).

The OMCREFLAIR and OMCTRANS AIR beams are detected only for monitoring, and their optical layout on ISCT6 is very simple (just a camera and/or a DC diode). However, in order to investigate different alignment schemes, we want to keep the option of routing the OMCREFLAIR beam to the ASAIR WFSs, which will be very easy to do with the proposed layout.

4.1 ASAIR beam

A small fraction of the AS beam is leaked through OM1, and split between the in vacuum *AS_C* QPD and the in-air AS path (ASAIR). A zoom of the ASAIR layout is shown in figure 8.

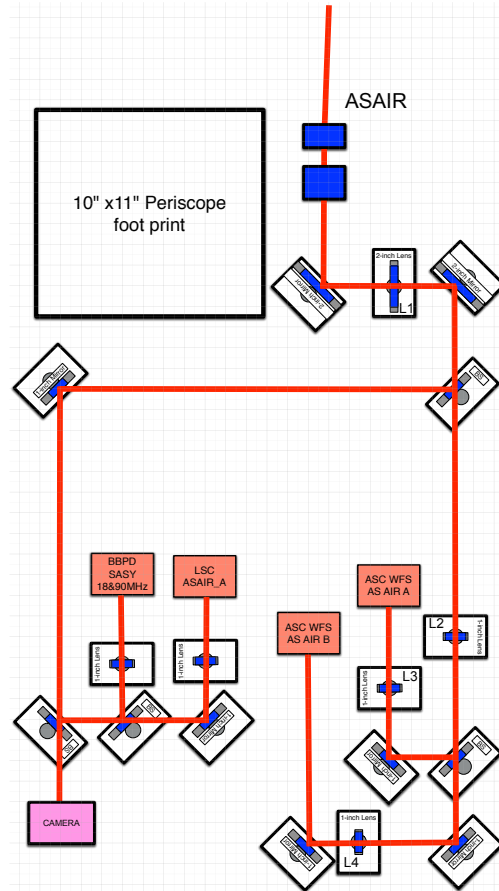

Figure 8: Zoom of the ASAIR beam path optical layout in ISCT6. Refer to the most recent version of D1201210 for updated information. For the exact location of the lenses refer to table 4.1.1.

The beam right after OM1 has the parameters summarized in table 4.1, and the beam profile is shown in figure 9.

4.1.1 ASAIR WFSs

A solution for the Gouy phase telescope of the ASAIR WFSs is shown in table 4.1.1 and in figure 11. The idea is to have a divergent lens in front of each WFS to be able to define the wanted beam size, while keeping a 90 degree Gouy phase separation between the two WFSs. Four lenses are used in this telescope:

Parameter	Value
q	$0.1430 + 1.0685i$ m
waistSize	$6.0158e-04$ m
waistZ	0.1430 m
divergenceAngle	$5.6299e-04$ rad
radiusOfCurvature	8.1256 m
beamWidth	$6.0694e-04$ m
rayleighRange	1.0685 m

Table 4: AS beam parameters in transmission of the first tip tilt mirror OM1.

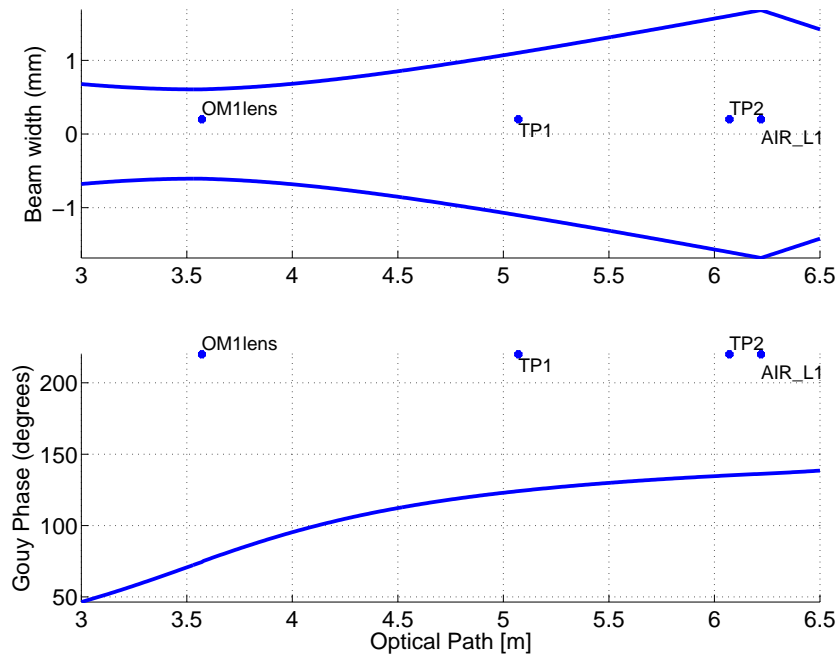

Figure 9: AS beam profile after transmitting through the first tip tilt mirror OM1.

- AIR.L1: 2" convergent lens, focal length = +1.146 m;
- AIR.L2: 1" convergent lens, focal length = +0.556 m;
- AIR.L3: 1" divergent lens, focal length = -0.0556 m;
- AIR.L4: 1" divergent lens, focal length = -0.111 m.

AIR.L1 and AIR.L2 reduce the size of the beam coming from HAM6. Then the beam is split in two paths, with a divergent lens in front of each WFS.

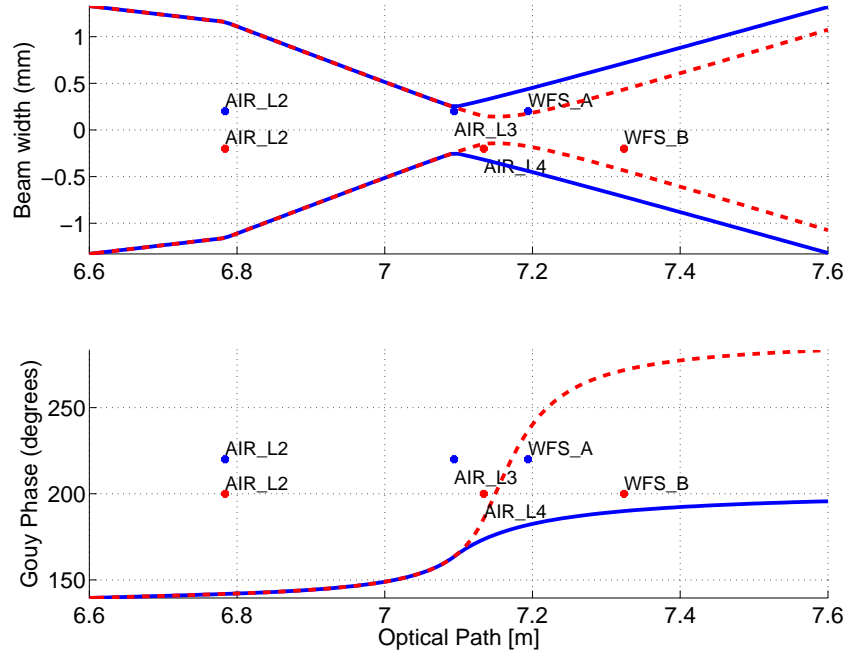

Figure 10: ASIAR WFS Gouy phase telescope: 4 lens solution.

Label	z [m]	Beam Width [mm]	Gouy Phase
SRM	0	2.07	0.2°
OM1lens	3.571	0.61	74.4°
AIR_L1	6.221	1.68	136.2°
AIR_L2	6.784	1.16	141.8°
AIR_L3	7.094	0.24	163.6°
WFS_A	7.194	0.44	181.9°
AIR_L4	7.134	0.15	217.7°
WFS_B	7.324	0.43	271.8°

Table 5: Beam parameters in the ASIAR path for the 4 lens solution.

An alternative solution is described in table 4.1.1: this solution uses only 2 lenses, instead of 4, but the beam size on the WFSs can not be adjusted independently from the Gouy phase separation.

- AIR.L1: 2" convergent lens, focal length = +0.687 m;
- AIR.L2: 1" convergent lens, focal length = -0.572 m;

Label	z [m]	Beam Width [mm]	Gouy Phase
SRM	0	2.07	0.2°
OM1	3.571	0.61	74.4°
AIR_L1	6.371	1.76	167.2°
AIR_L2	6.784	1.13	137.2°
WFS_A	7.14	0.45	161.7°
WFS_B	7.74	0.45	250.7°

Table 6: Alternative solution for the ASAIR beam path with only a 2 lens telescope.

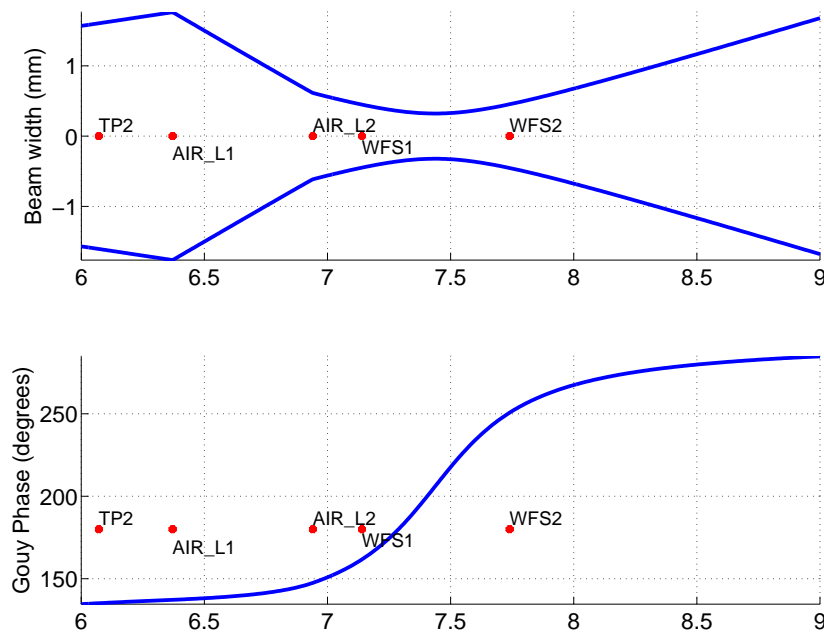

Figure 11: ASIAR WFS Gouy phase telescope: 2 lens solution.

References

- [1] S. Waldman, *ISC In-vacuum Gouy phase telescopes*, LIGO-T1000247
- [2] P. Fritschel et al, *AdvLIGO Interferometer Sensing and Control Conceptual Design*, LIGO-T070247
- [3] L. Barsotti, M. Evans *Modeling of alignment sensing and control for Advanced LIGO*, LIGO-T0900511
- [4] K. Kawabe, *Mode Matching Telescope for Advanced LIGO Output Mode Cleaners* LIGO T1000317-v1

[5] S. Waldman *Output Mode cleaner Design* LIGO T1000276