

E1200802-v4

Notes on Initial Alignment of the L1 Power Recycling Cavity (PRC)

Supplementary notes to the alignment solution calculated in E1200797-v6

Dennis Coyne

19 Feb 2013

The initial alignment scope and approach for the PRC is to:

- 1) align (pitch, yaw, x, y and z) the PRM, PR2 and PR3 each separately (in any order) with the total station positioned at various points on a pipe bridge stand in the region between LHAM3 and LBSC2 (after removal of the vacuum equipment spool and septum plate)
- 2) then check the co-alignment, or collective alignment, of the PRC by sending an alignment beam along the chief ray toward PR3 (from the direction of the BS) and letting it reflect off PR2, retroreflect off the PRM HR surface and return to the Total Station

The available alignment reference monuments for the PRC are along the $X = -1858.0$ mm line, i.e. monuments "L1 IAM 377" to "L1 IAM 379", as defined in [E1100374-v5](#) and [D1200869-v8](#). This reference line will be extended into the spool region between LHAM3 and LBSC2 in order to mark Total Station locations on the pipe bridge stand. This line places the Total Station 16 inches from the LBSC2 flange. This clearance is deemed acceptable, but requires the operator to be in the LBSC2 main port. See Figure 1.

Note that an alternative yaw reference can be obtained by using the $Y = -2245.5$ mm line (defined by monuments L1-IAM-378, L1-IAM-382, AM-400, AM-401 and AM-402) to align an Optical Transit Square. The Total Station can then be optically squared off of the Transit Square.

Each of the three PRC optics have a significant radius of curvature, which requires pitch and yaw alignment to be performed by retro-reflection from the center of each optic.

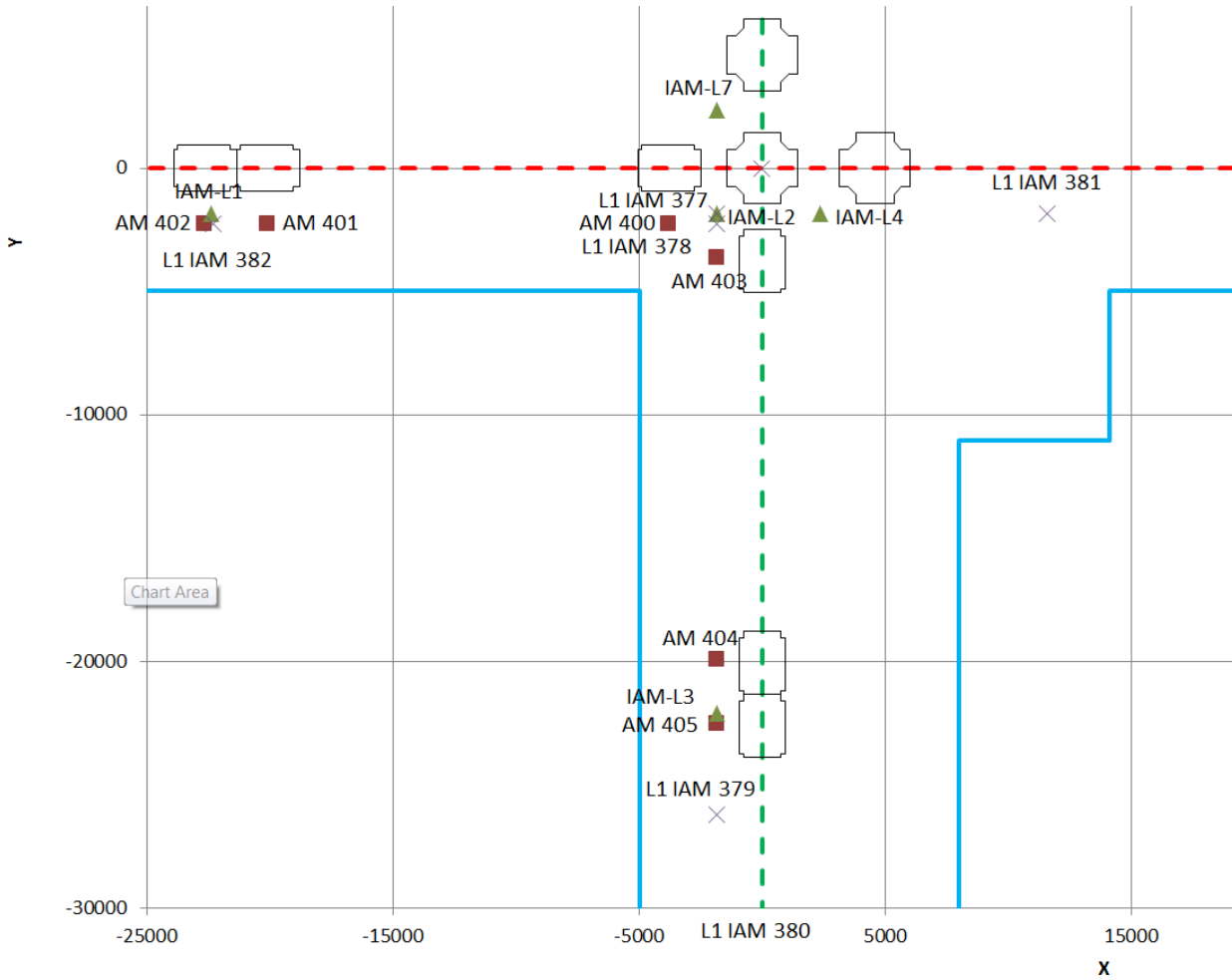

Figure 1: L1 LVEA Monument Layout near the PRC

PR3 Pitch & Yaw Alignment

The view of the center of the PR3 optic, on an axis normal to the HR face at the center, is blocked by the PR2 suspension structure. Consequently a Lateral Transfer Hollow Periscope (LTHP) is used in the LHAM3 spool on the +X side of the Mode Cleaner Tube Baffle to ‘jog’ the beam around the PR2 suspension as shown in

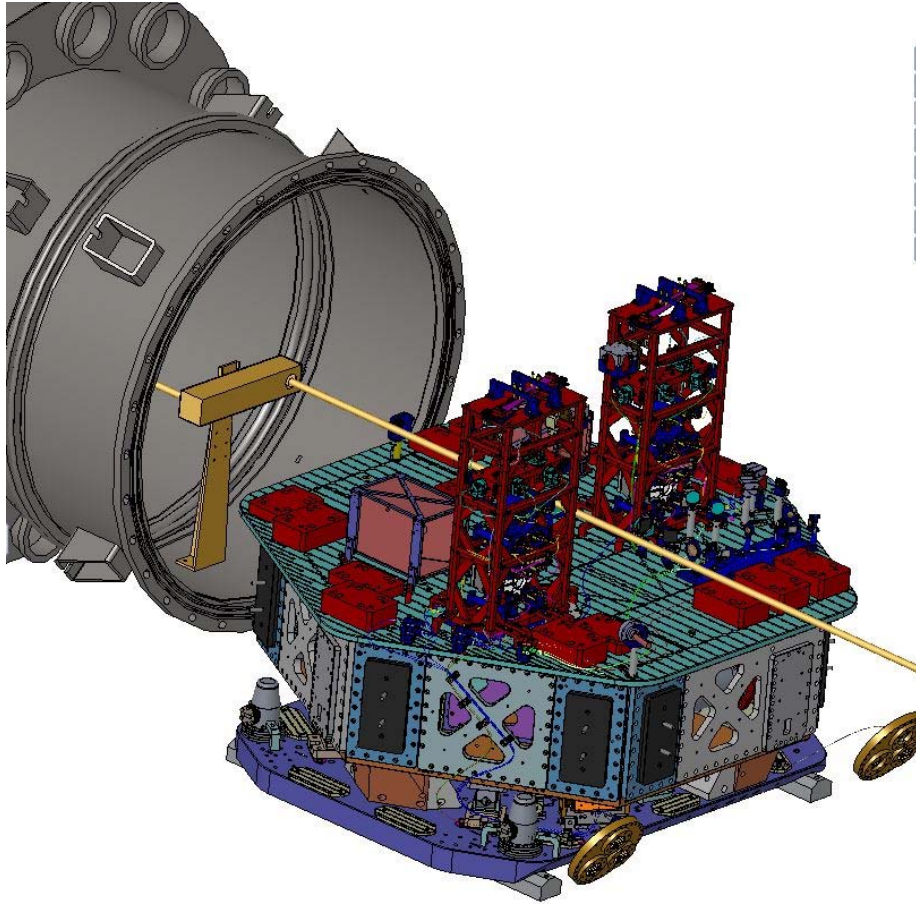

Figure 2: Oblique view of the pitch & yaw alignment beam for PR3 with a LTHP

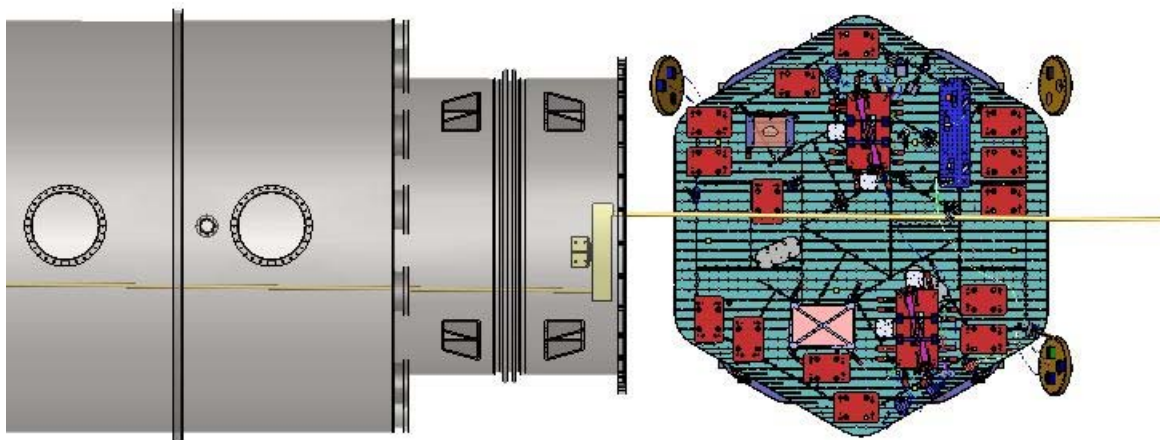

Figure 3: Top view of the pitch & yaw alignment beam for PR3 with a LTHP

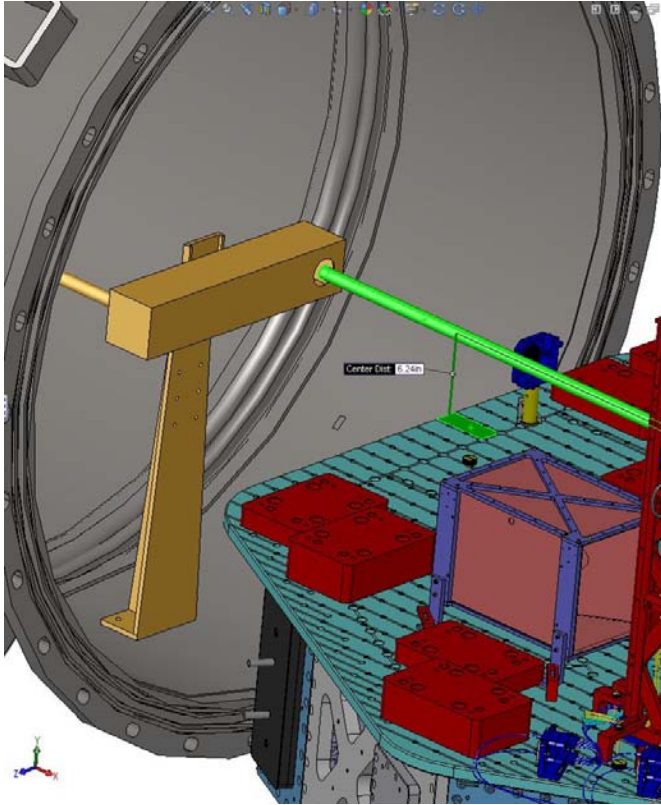
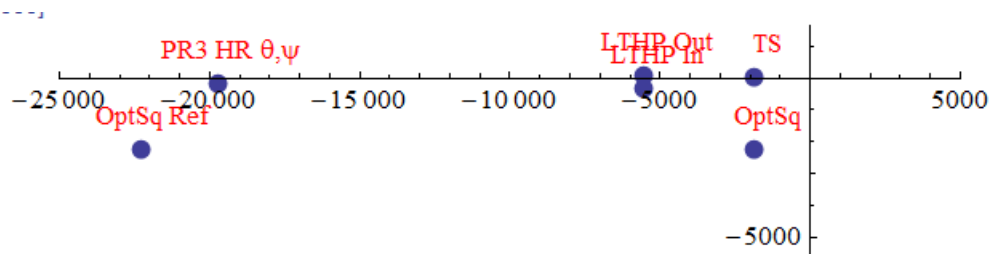

Figure 4: Close up view of the LTHP used for pitch & yaw alignment of the PR3



PR3 Positional Alignment

In order to align the position of the PR3, the Total Station is simply placed along the alignment reference line ($x = -1858.0$ mm) and at $y = 0$ mm and then pointed to the center of the optic. The top, bottom, left and right edges of the optic are then sighted to confirm that the optic is centered. If it isn't centered then the optic is adjusted in lateral and vertical position until it is centered.

The longitudinal position is determined with the use of the retro-reflector mount.

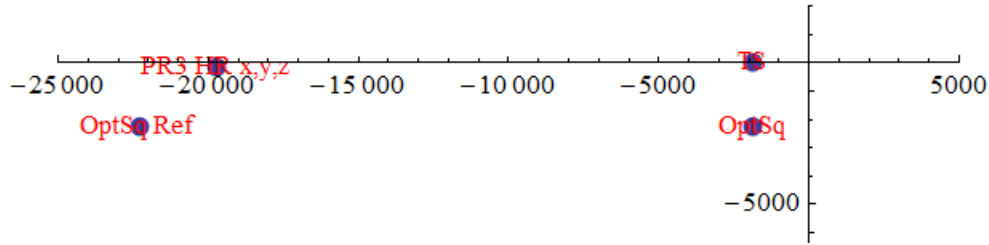

PR2 Pitch & Yaw Alignment

It is possible that the PR2 optic can be aligned from the flat AR side. However this relies of very accurate metrology of the relative angle between the AR side and the axis of the ROC on the HR side. To be conservative we will assume alignment using an extended retro-reflector (a Lateral Transfer Hollow Retro-reflector (LTHR)) to view the HR surface.

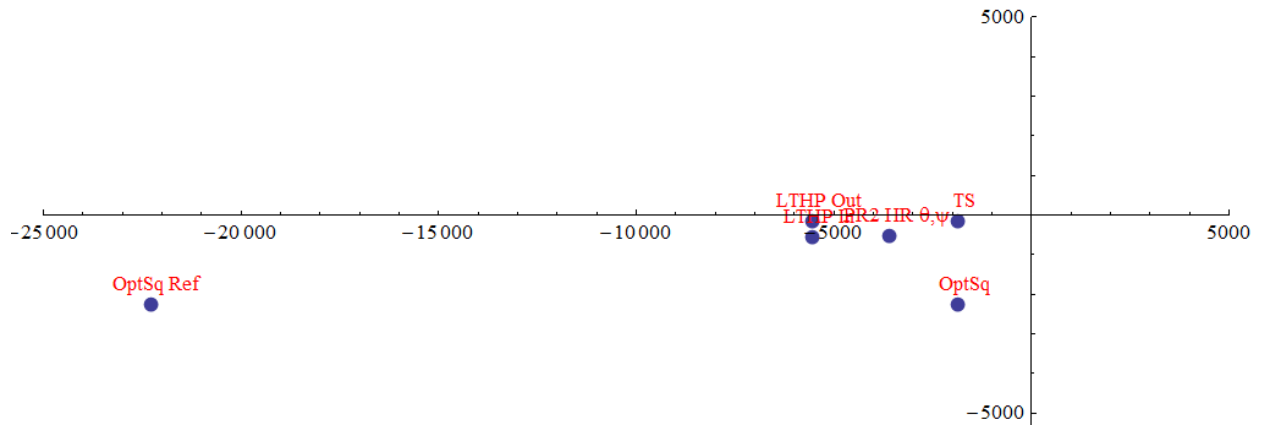

PR2 Positional Alignment

The backside (AR side) of the PR2 is visible from the Pipe Bridge location between LHAM3 and LBSC2, as shown in Figure 5 and Figure 6. The PR2 optic can be positioned laterally and vertically by sighting the top, bottom, left and right edges of the optic.

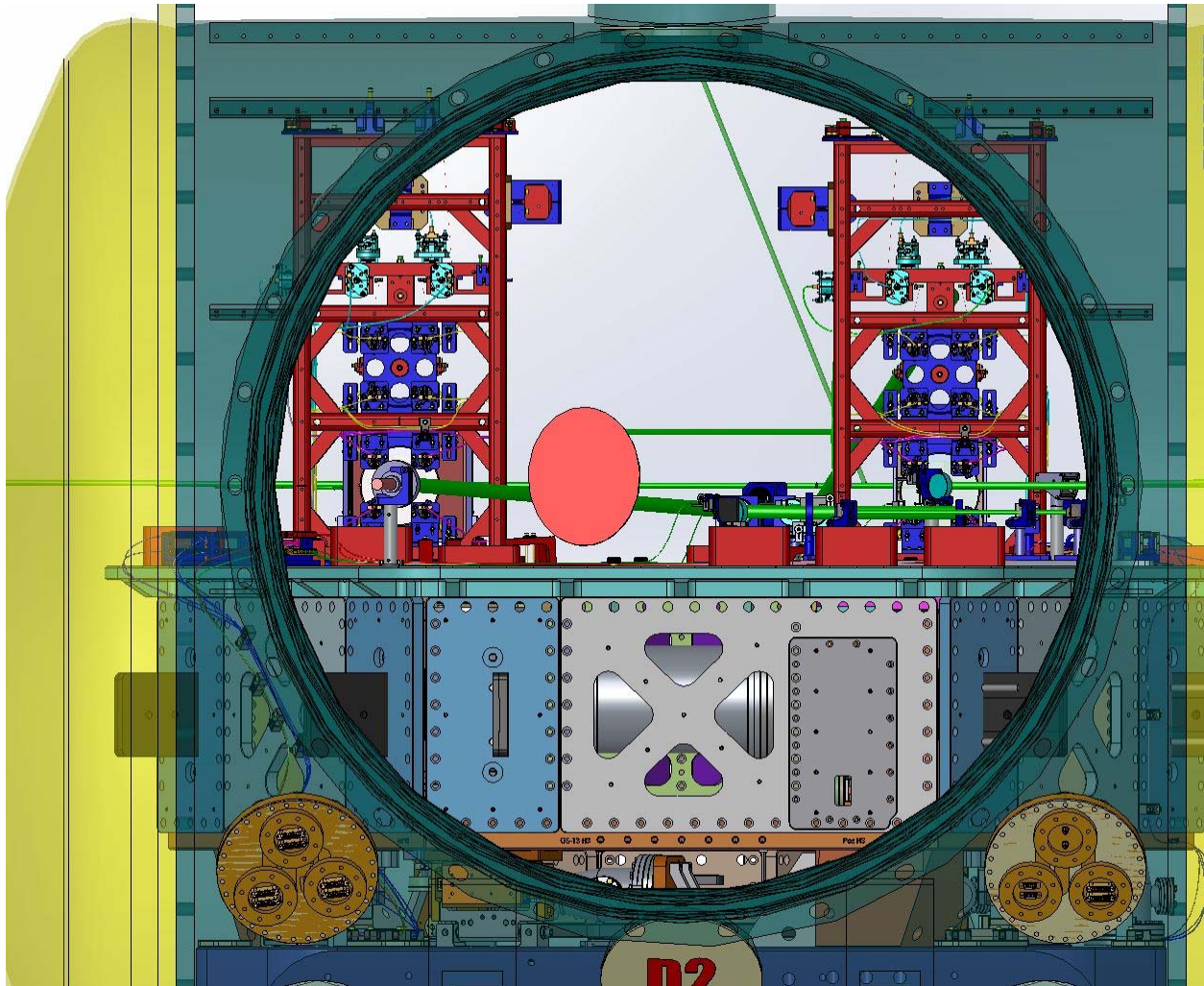

Figure 5: View from LBSC2 looking in the $-X$ direction at LHAM3. Note that the AR side of PR2 (the suspension on the left) is visible.

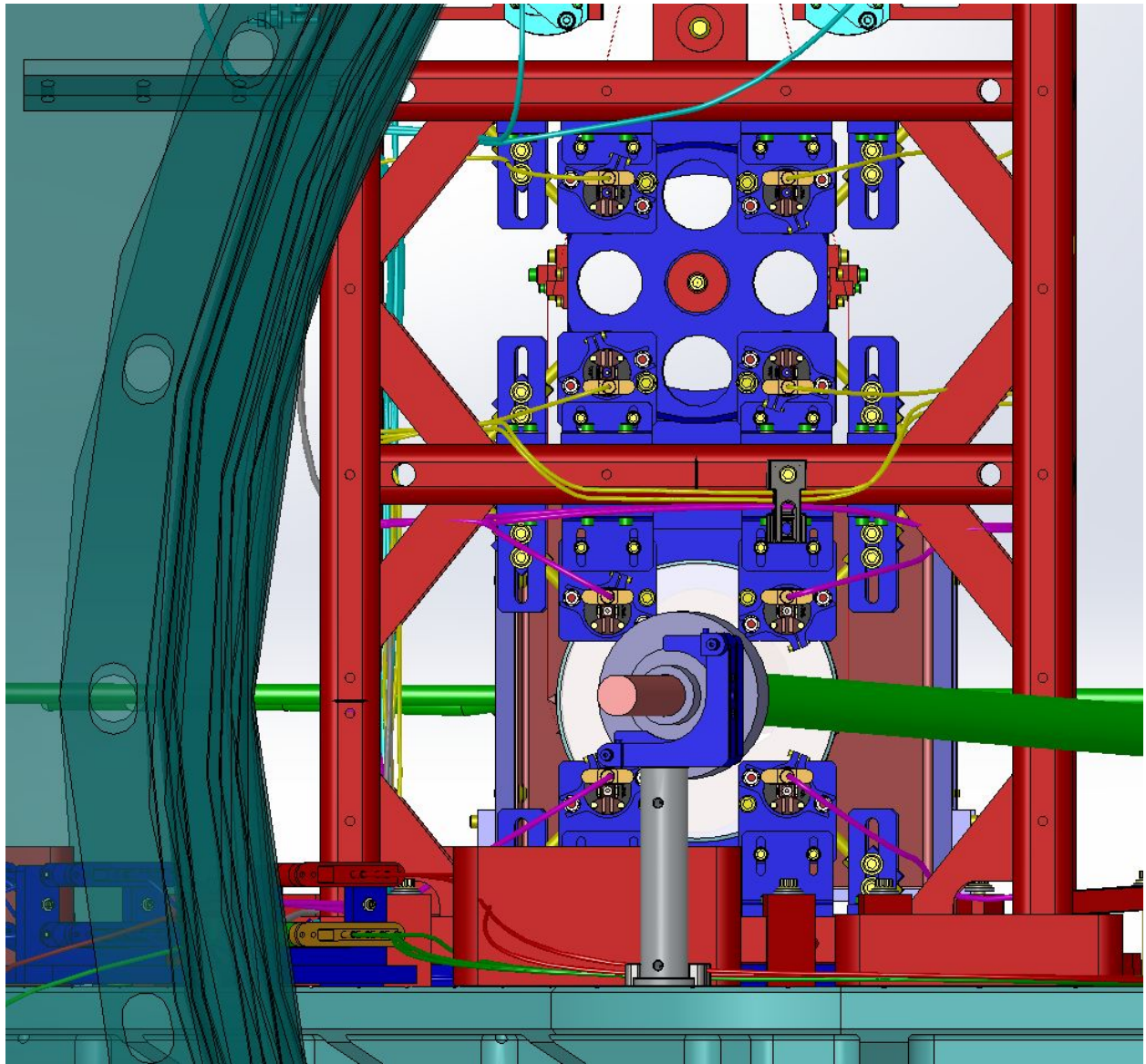
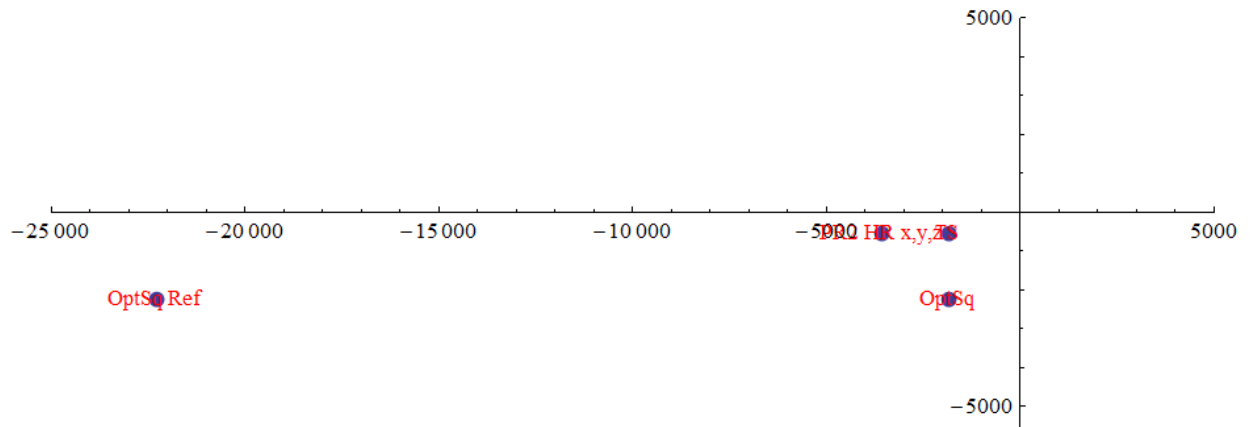
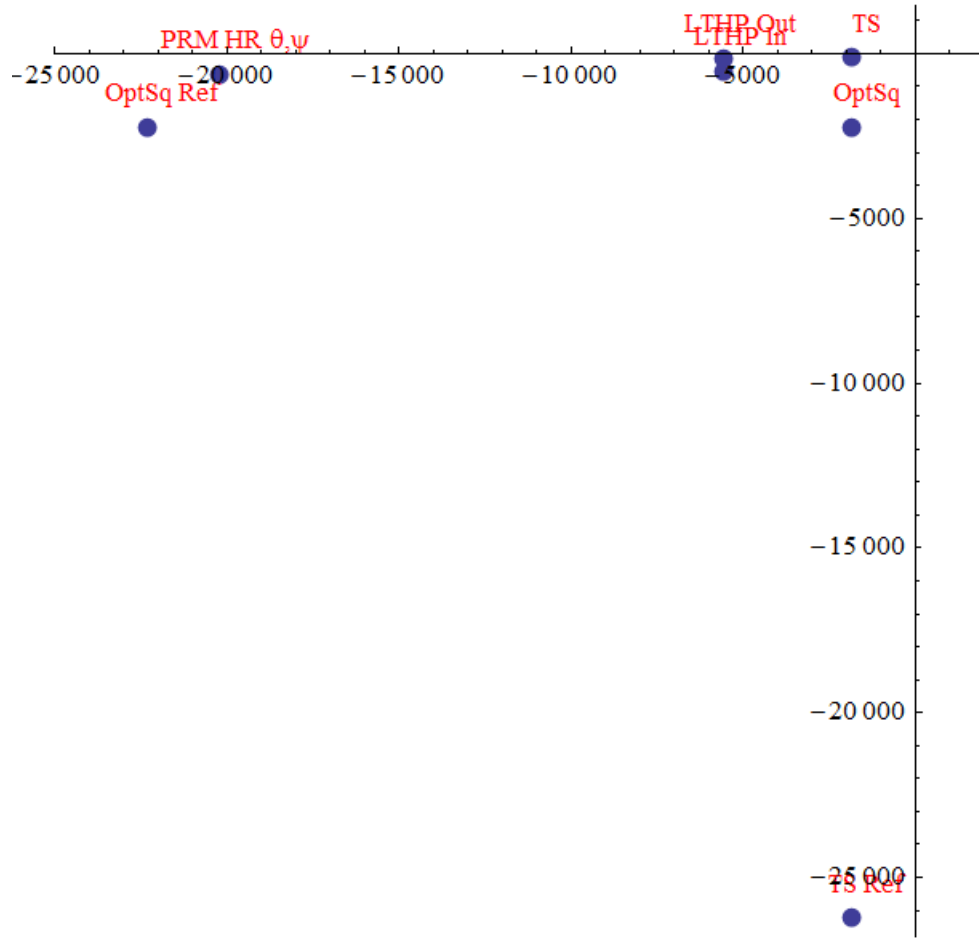

Figure 6: AR Side view of PR2



PRM Pitch & Yaw Alignment



PRM Positional Alignment

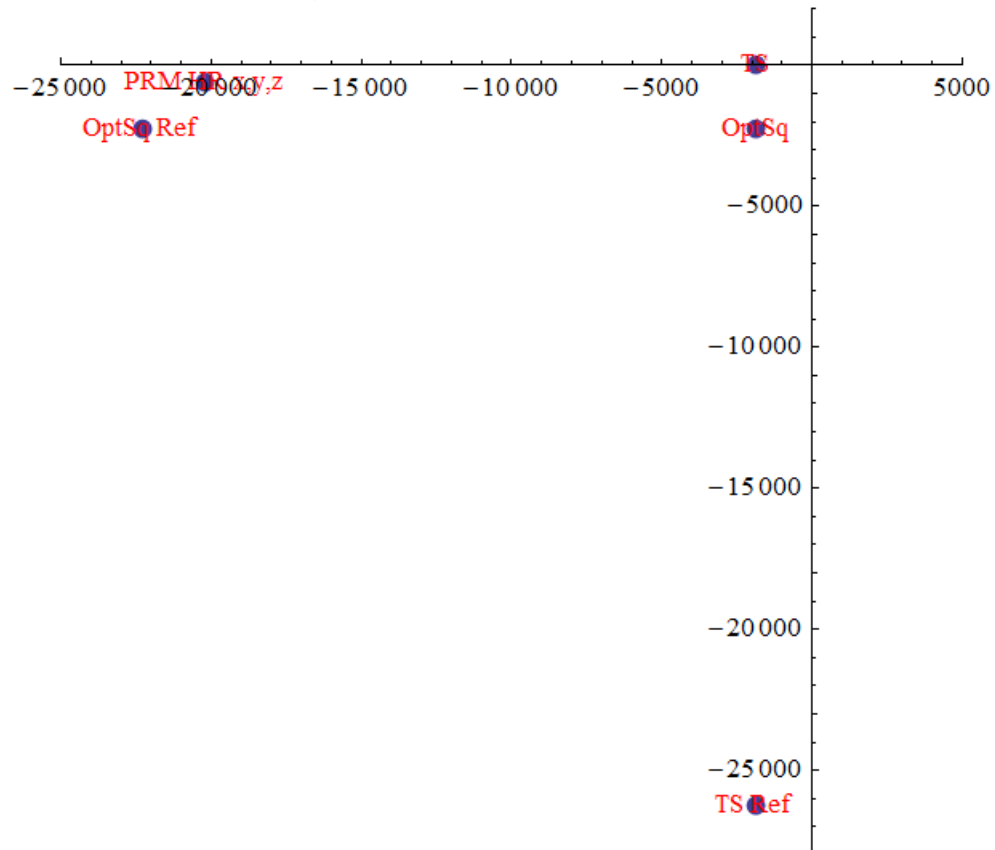

PRC Co-Alignment Check

TBD – same Total Station position as used for BS alignment (i.e. along beam path from BS center to PR3 center), although pointed in the opposite direction

Table 1: Details of the alignment solutions for the L1 PRC Optics

35]=

Name	Alignment			Transit Square						Total Station									PLX						
	Local Coordinates (mm)			Over Monument (mm)			Sights Monument (mm)			Over Monument (mm)				Sights Monument (mm)			Distance (mm)	Yaw			Pitch			LTHR	LTHP
	Xl	Yl	Zl	Name	Xl	Yl	Name	Xl	Yl	Name	Xl	Yl	Zl	Name	Xl	Yl		deg	min	sec	deg	min	sec		
PRM HR x,y,z	-20189.6	-628.1	-96.7	L1 IAM 378	-1858.0	-2245.5	L1 IAM 382	-22283.5	-2245.5	am 501	-1858.0	0.0	-96.7	L1 IAM 379	-1858.0	-26231.2	18342.4	88.	2.	16.	0.	0.	0.		
PRM HR θ,ψ	-20189.6	-628.1	-96.7	L1 IAM 378	-1858.0	-2245.5	L1 IAM 382	-22283.5	-2245.5	am 500	-1858.0	-120.3	-91.8	L1 IAM 379	-1858.0	-26231.2	18734.3	89.	39.	48.	0.	0.	-55.		Y
PR2 AR x,y,z	-3579.2	-530.5	-92.3	L1 IAM 378	-1858.0	-2245.5	L1 IAM 382	-22283.5	-2245.5	am 503	-1858.0	-544.2	-92.3	L1 IAM 379	-1858.0	-26231.2	1646.3	90.	27.	32.	0.	0.	0.		
PR2 HR θ,ψ	-3579.2	-530.5	-92.3	L1 IAM 378	-1858.0	-2245.5	L1 IAM 382	-22283.5	-2245.5	am 502	-1858.0	-144.2	-92.3	L1 IAM 379	-1858.0	-26231.2	6059.8	90.	27.	32.	0.	0.	0.	Y	
PR3 HR x,y,z	-19740.0	-176.5	-87.9	L1 IAM 378	-1858.0	-2245.5	L1 IAM 382	-22283.5	-2245.5	am 505	-1858.0	0.0	-87.9	L1 IAM 379	-1858.0	-26231.2	17882.9	89.	26.	4.	0.	0.	0.		
PR3 HR θ,ψ	-19740.0	-176.5	-87.9	L1 IAM 378	-1858.0	-2245.5	L1 IAM 382	-22283.5	-2245.5	am 504	-1858.0	24.3	-87.9	L1 IAM 379	-1858.0	-26231.2	18278.7	90.	38.	19.	0.	0.	0.		Y