

BSC HEPI Motion

Tim MacDonald

9/26/14

The Issue

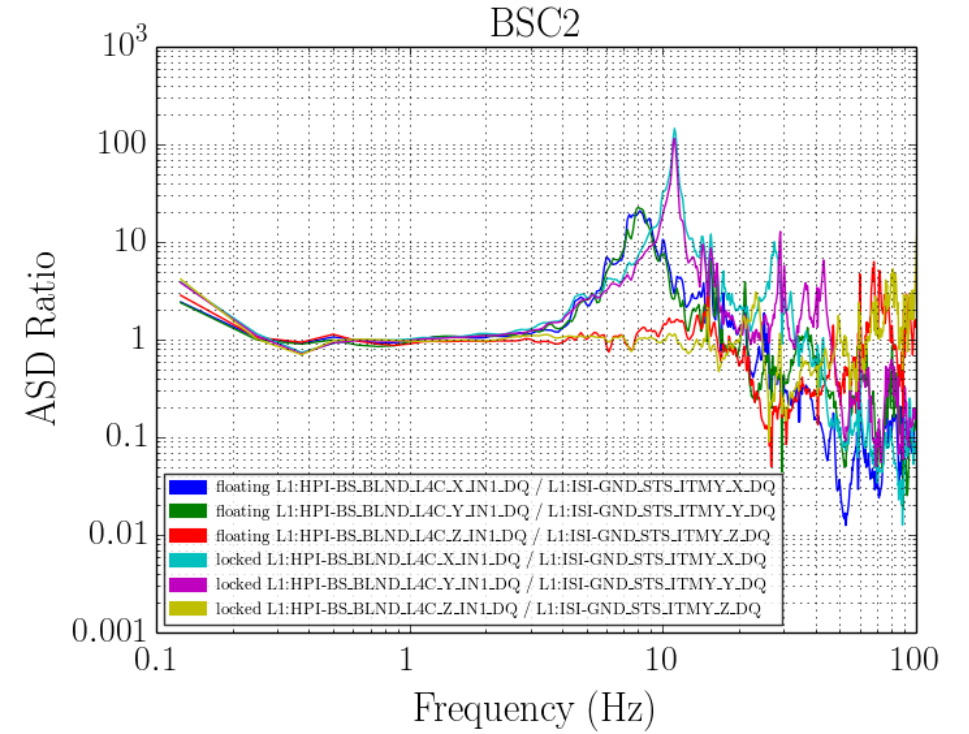
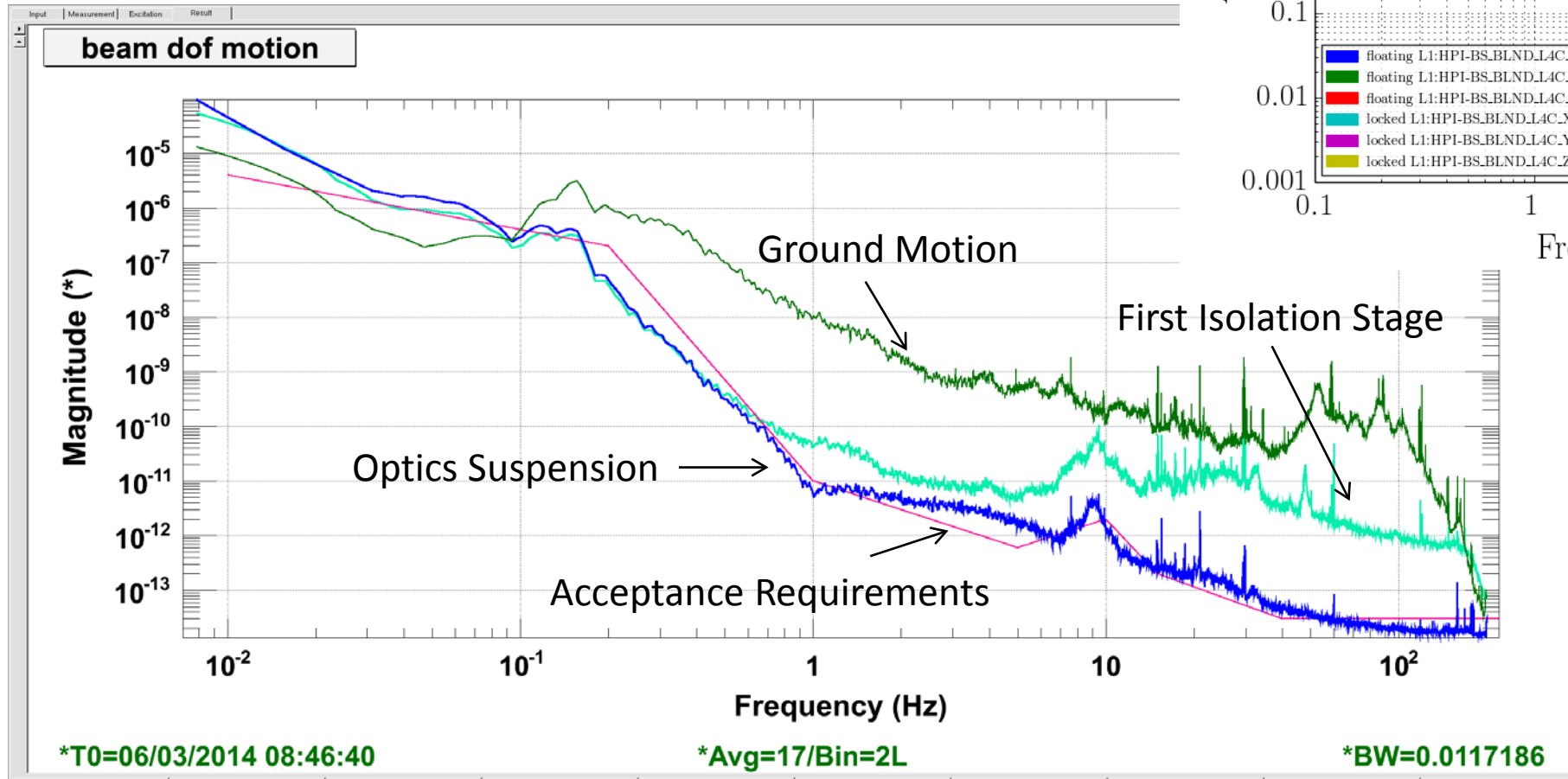

LASTI Result (2005)

- LASTI measurements suggested floor motion was coupled with pier motion

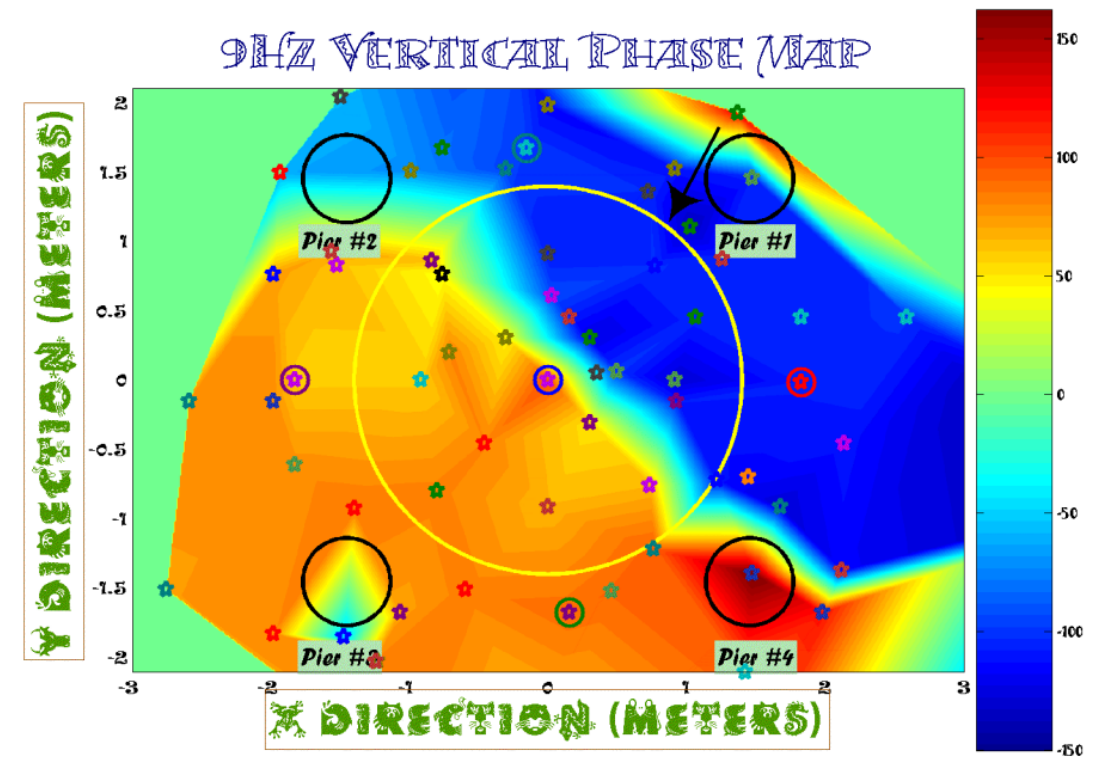
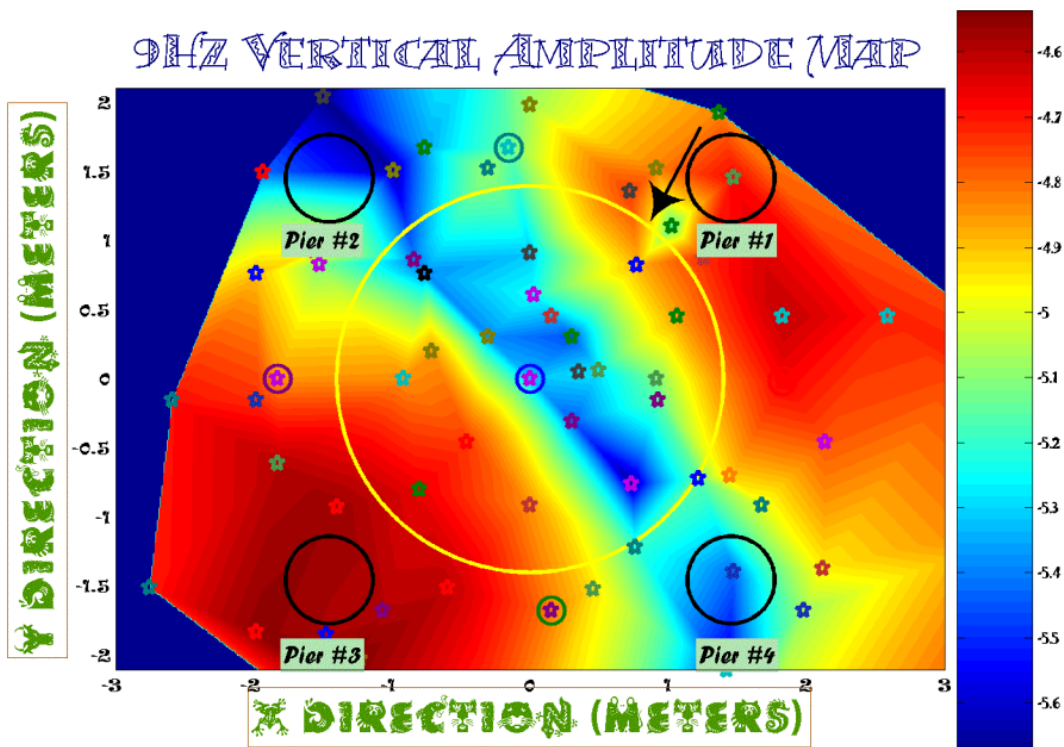

Modeling Efforts

- Christophe at the University of Brussels (Abaqus)
- Stanford (ANSYS)

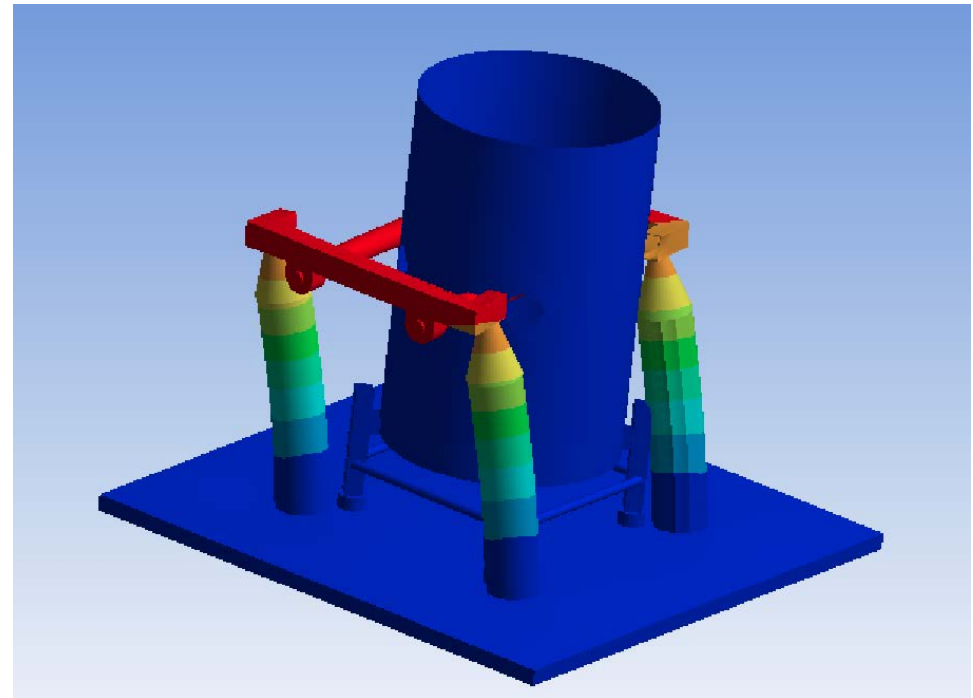
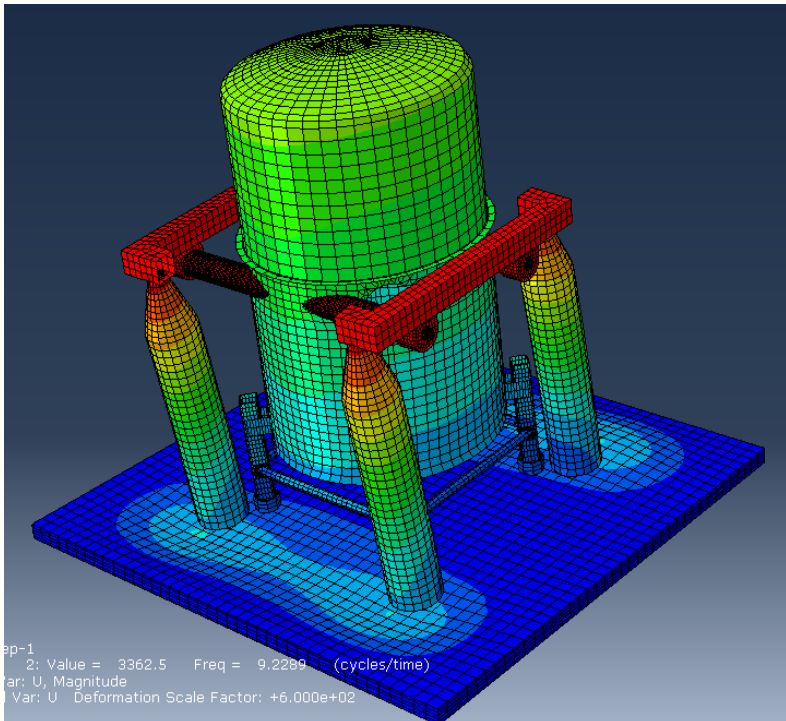

Modeling Results

- Models do not clearly agree with measurements or between models
- Variation of boundary conditions led to different results
- Unclear which BCs to use

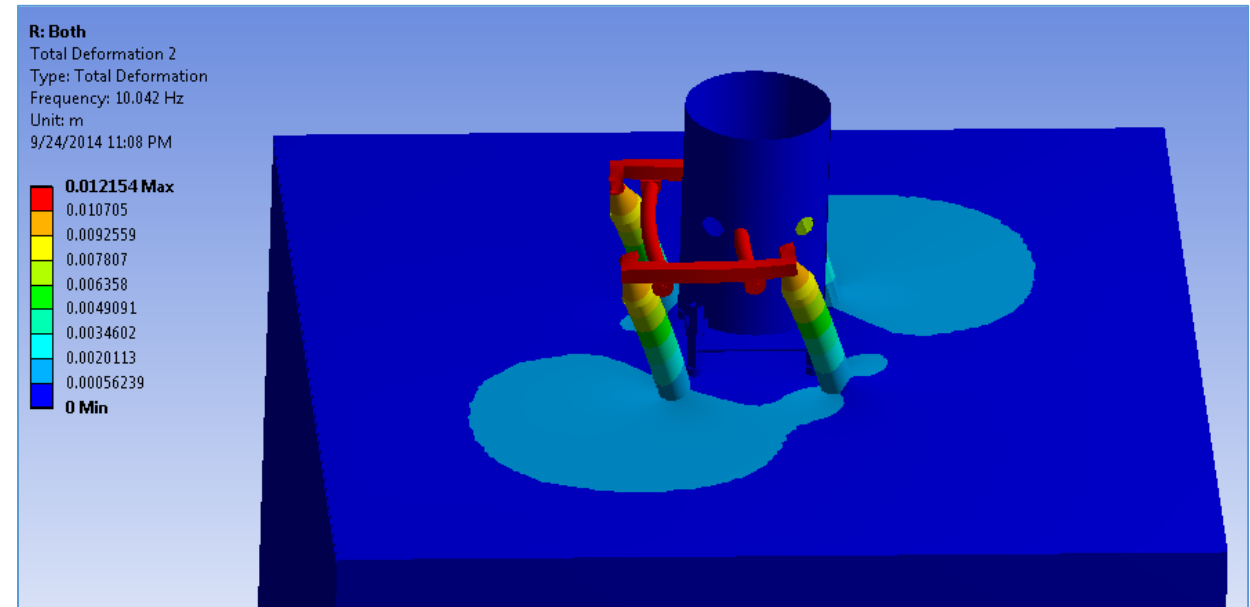
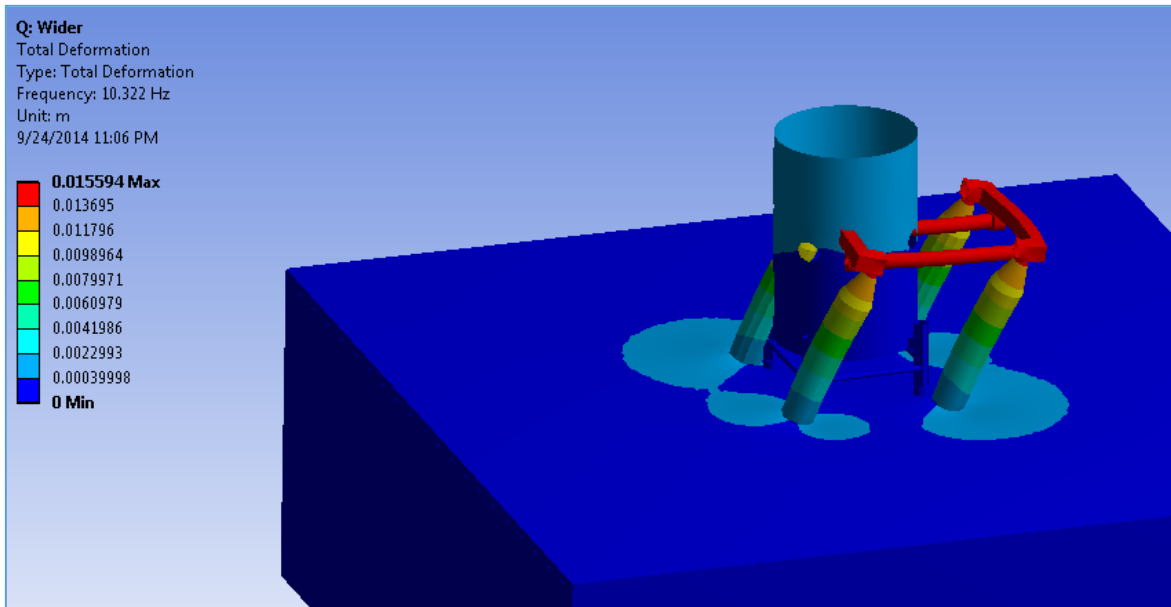

Real Information Needed

- Want specific mode shapes to determine how the floor and the rest of the structure is moving
- B&K system can be used for this function



Hardware Setup Measurement Template: Modal																		
All	Aux	Basic	Calibration	Channel	Ext. Amp	Transducer	Vibration											
Filter	Status	Frame	Module	Slot	Chn	Channel Type	Transducer Family	Transducer Type	Transducer Serial Number	Transducer Name	Transducer Description	Transducer Nom. Sensitivity	Use External Amplifier	External Amplifier Gain	TEDS Information	Calibration Time	Accredited Calib. Sensitivity	Use Transducer Data
1.1.1	█		3050-B-0	1	1	Input	Accelerometer	4506 Bx	30740	4506 Bx	DeltaTron	10m V/ms ⁻²	<input type="checkbox"/>	1 V/V	<Manufact...	12/4/2008	9.72m	<input checked="" type="checkbox"/>
1.1.2	█		3050-B-0	1	2	Input	Accelerometer	4506 Bz	30740	4506 Bz	DeltaTron	10m V/ms ⁻²	<input type="checkbox"/>	1 V/V	<Manufact...	12/4/2008	9.971m	<input checked="" type="checkbox"/>
1.1.3	█		3050-B-0	1	3	Input	Accelerometer	4506 By	30740	4506 By	DeltaTron	10m V/ms ⁻²	<input type="checkbox"/>	1 V/V	<Manufact...	12/4/2008	9.882m	<input checked="" type="checkbox"/>
1.1.4	█		3050-B-0	1	4	Input							<input type="checkbox"/>					<input type="checkbox"/>
1.1.5	█		3050-B-0	1	5	Input							<input type="checkbox"/>					<input type="checkbox"/>
1.1.6	█		3050-B-0	1	6	Input							<input type="checkbox"/>					<input type="checkbox"/>
1.2.1	█		3050-B-0	2	1	Input	Accelerometer	4506 Bx	30698	4506 Bx	DeltaTron	10m V/ms ⁻²	<input type="checkbox"/>	1 V/V	<Manufact...	1/7/2009	9.703m	<input checked="" type="checkbox"/>
1.2.2	█		3050-B-0	2	2	Input	Accelerometer	4506 By	30698	4506 By	DeltaTron	10m V/ms ⁻²	<input type="checkbox"/>	1 V/V	<Manufact...	1/7/2009	9.015m	<input checked="" type="checkbox"/>
1.2.3	█		3050-B-0	2	3	Input	Accelerometer	4506 Bz	30698	4506 Bz	DeltaTron	10m V/ms ⁻²	<input type="checkbox"/>	1 V/V	<Manufact...	1/7/2009	10.13m	<input checked="" type="checkbox"/>
1.2.4	█		3050-B-0	2	4	Input							<input type="checkbox"/>					<input type="checkbox"/>
1.2.5	█		3050-B-0	2	5	Input							<input type="checkbox"/>					<input type="checkbox"/>
1.2.6	█		3050-B-0	2	6	Input							<input type="checkbox"/>					<input type="checkbox"/>
1.3.1	█		3160-B-0	3	1	Input	Force	8207		8207	Hammer	227u V/N	<input type="checkbox"/>	1 V/V			227u V/N	<input checked="" type="checkbox"/>
1.3.2	█		3160-B-0	3	2	Input							<input type="checkbox"/>					<input type="checkbox"/>
1.3.3	█		3160-B-0	3	3	Input							<input type="checkbox"/>					<input type="checkbox"/>
1.3.4	█		3160-B-0	3	4	Input							<input type="checkbox"/>					<input type="checkbox"/>

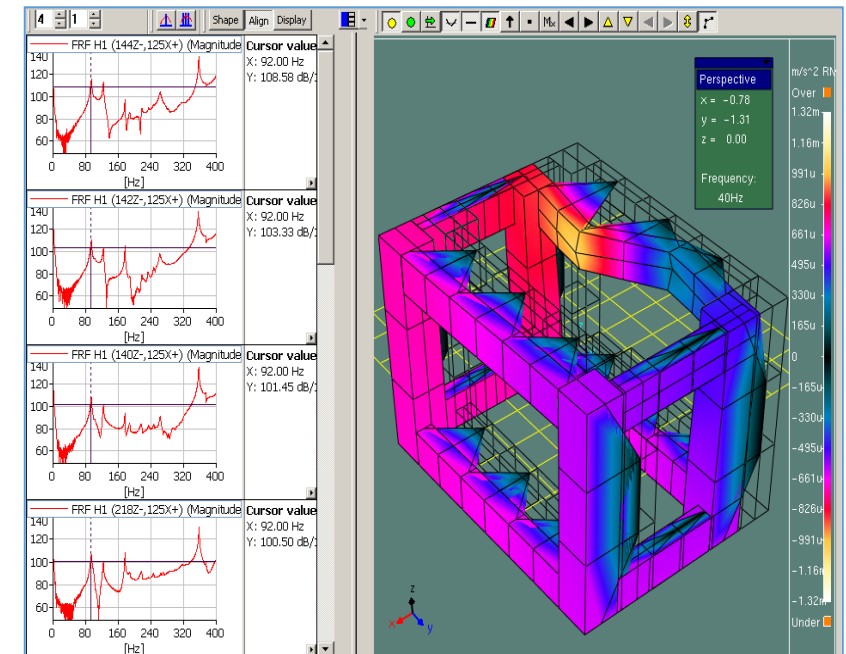

B&K Setup at LHO

- Three 4506 accelerometers
- One 8340 accelerometers (the big one)
- 8208 Impact hammer (3 lb)
- 8206 Impact hammer

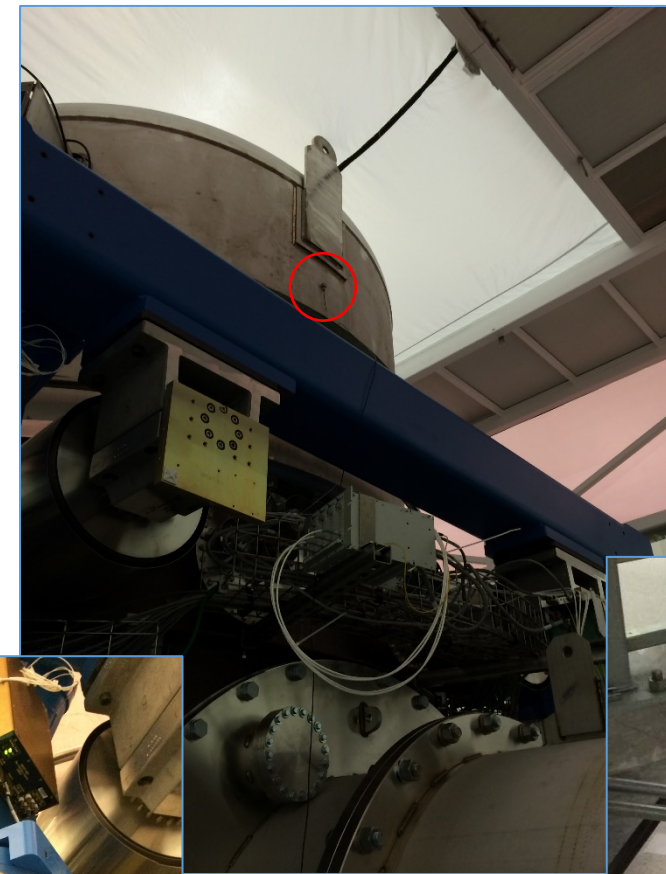
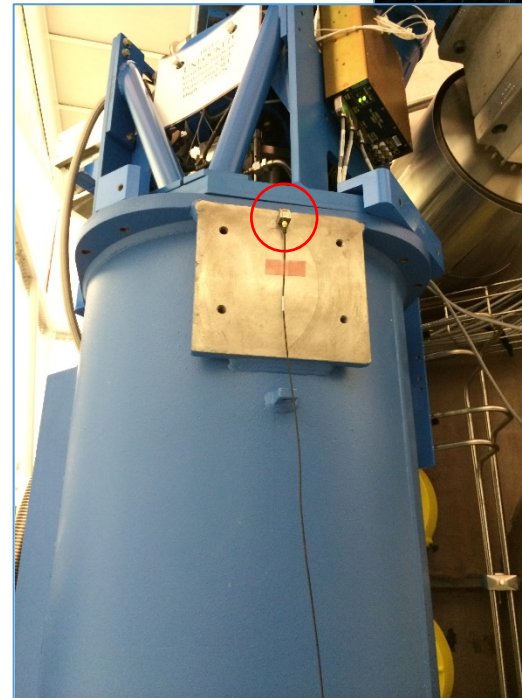
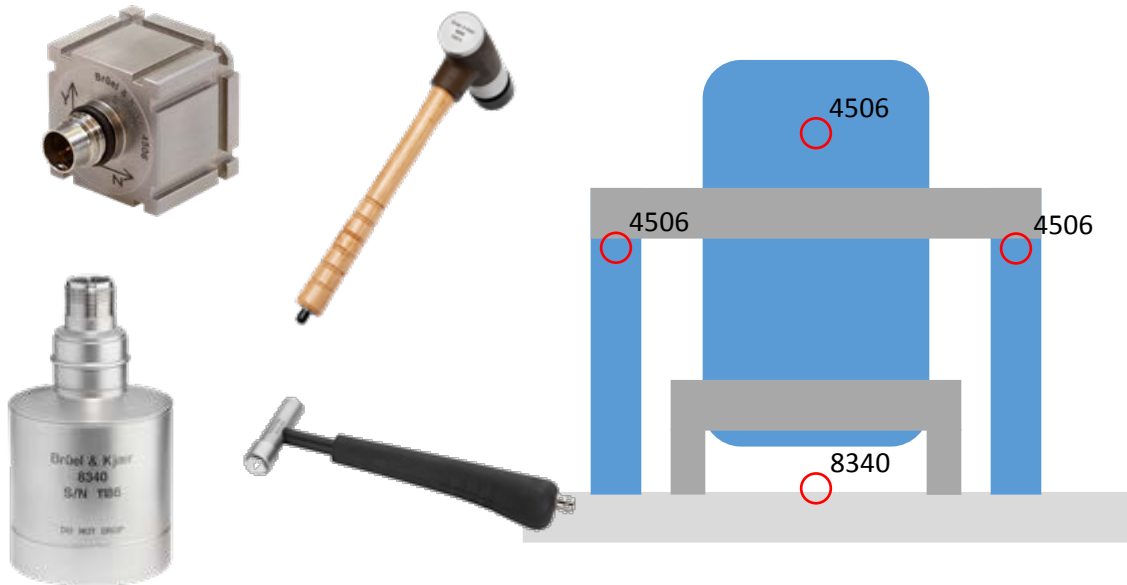

Initial Measurements

- Hammer hits on the floor and pier
- Nothing seen near 8 Hz
- Low coherence on 4506s
- Moved 8340 to pier, still nothing

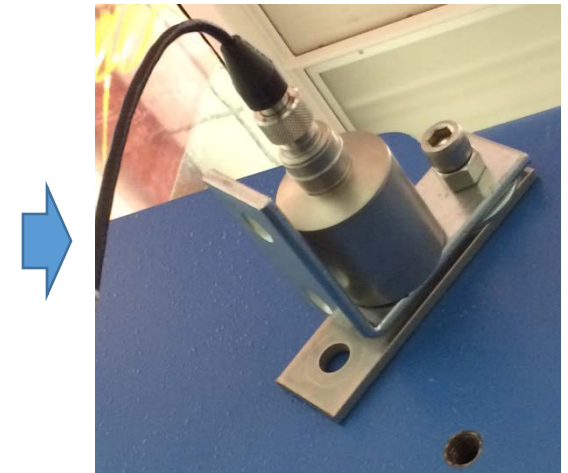
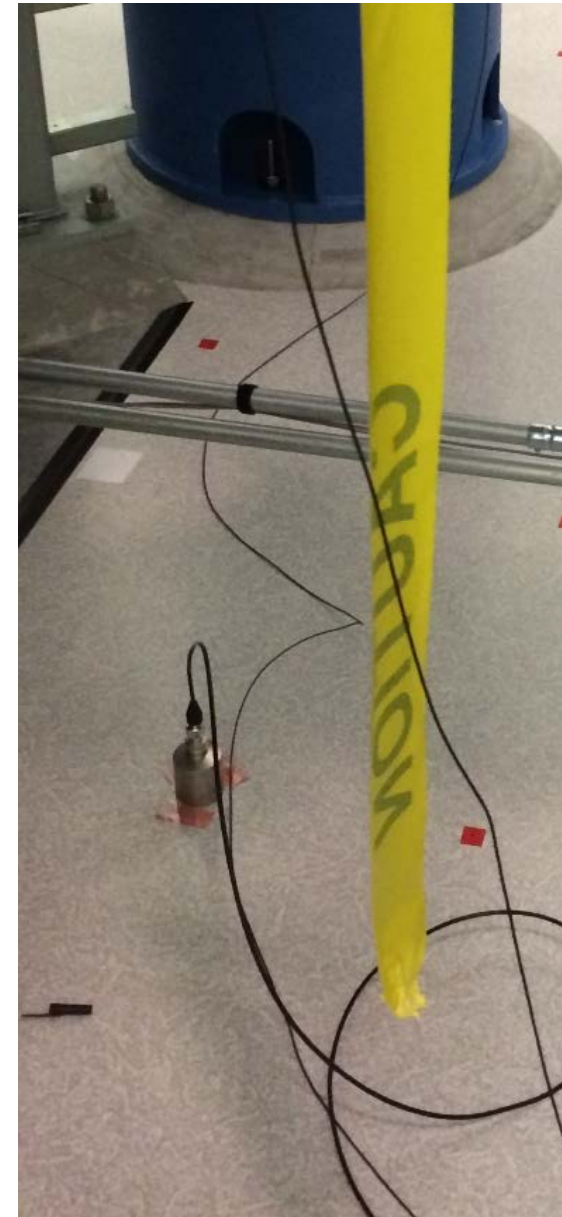

Initial Measurements

- Check L4C data and location
- L4C location in foot had not been hit
- Tried an impact on the crossbeam

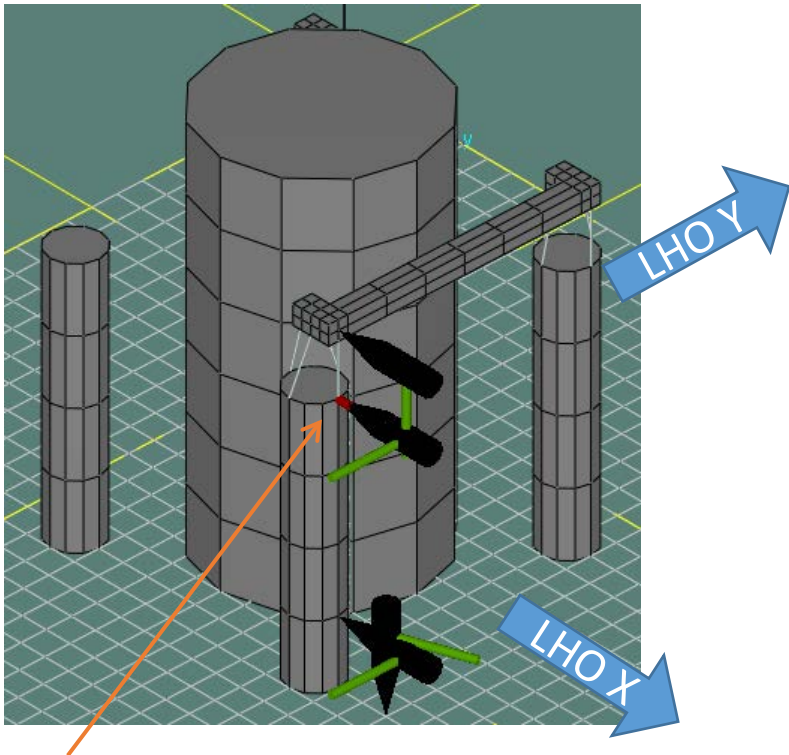

8340 Location



8340 Frequency Response by Impact Location

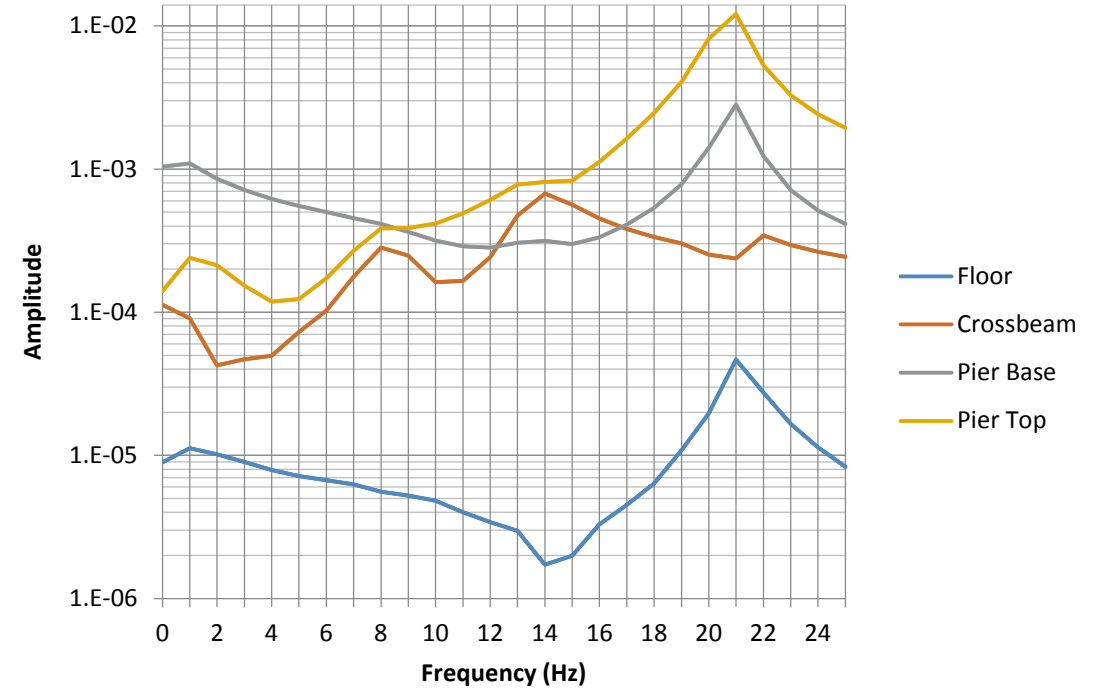

8340 Coherence by Impact Location

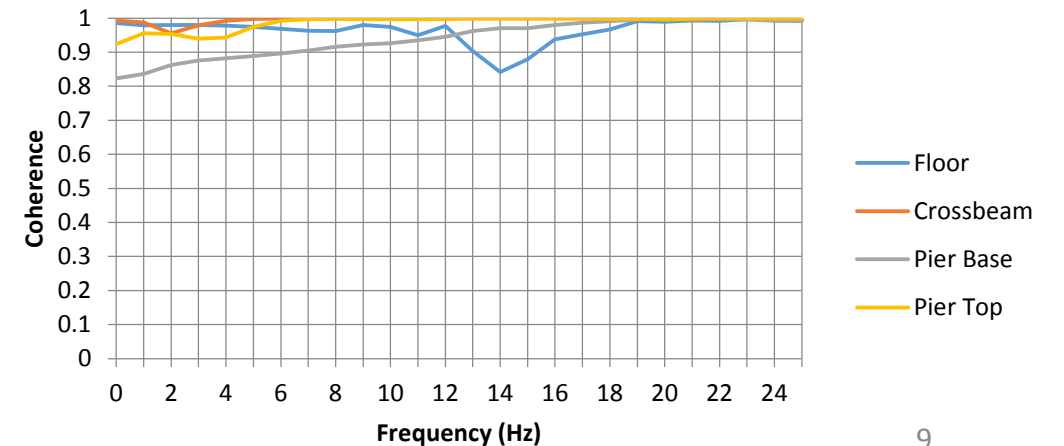

Full Floor System Measurement

- Created hit pattern up and around BSC
- Included the crossbeam

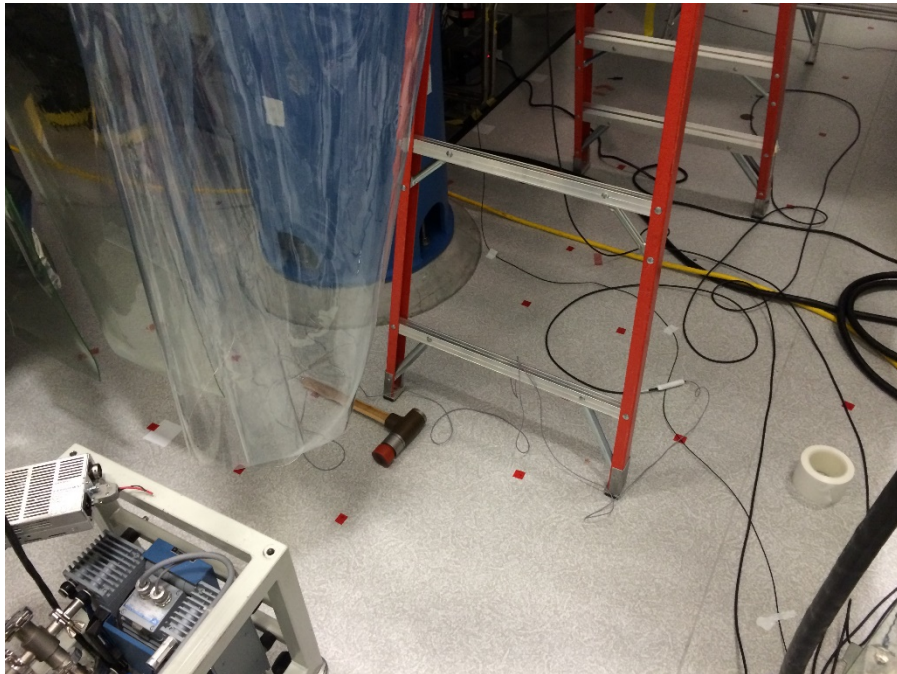

Full System Results

- Motion in crossbeam roughly 2-3x pier motion
- Almost no motion visible in the floor
- Crossbeam does not appear to bend

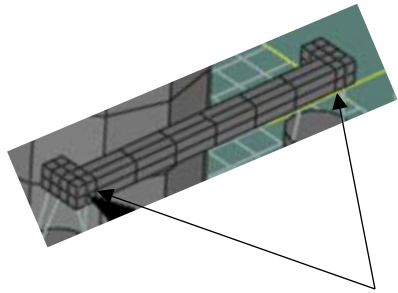

Lack of impact at these points creates illusion of bending. Motion only appears at impact points.

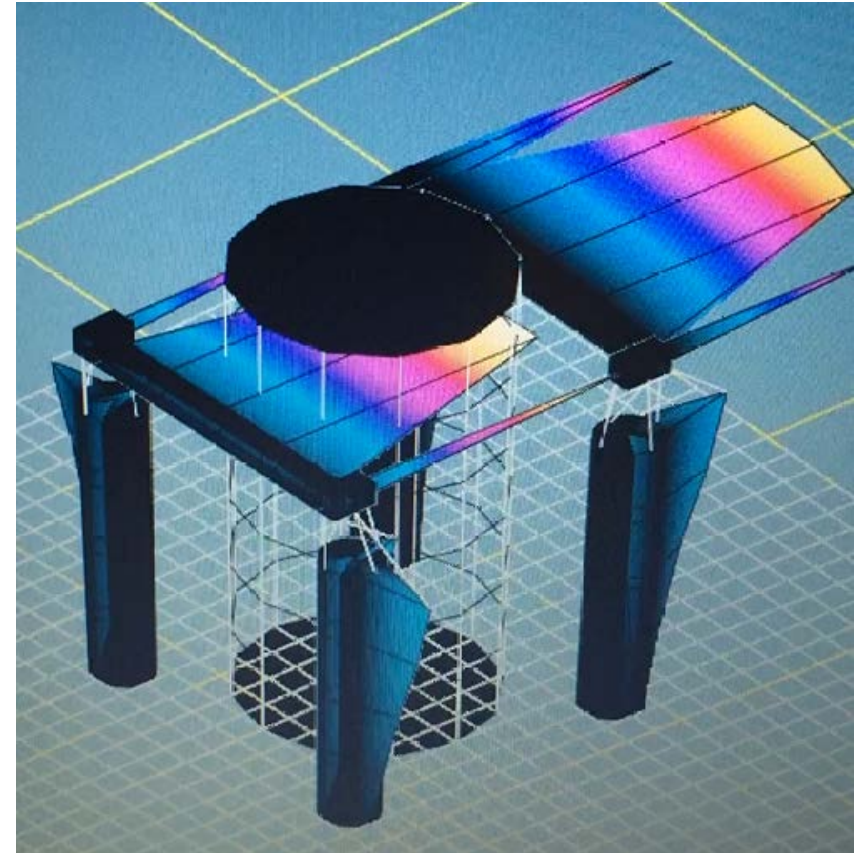

Measurements including HEPI

- New sequence including the HEPI actuator system
- Large motion seen with the foot, about twice the crossbeam
- Odd in that it only appears at the low point of the foot

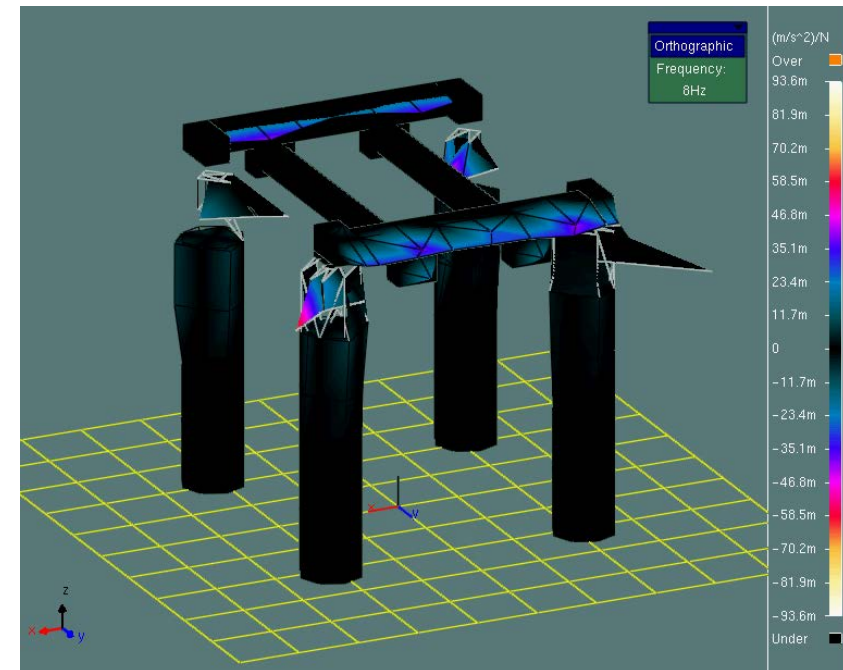
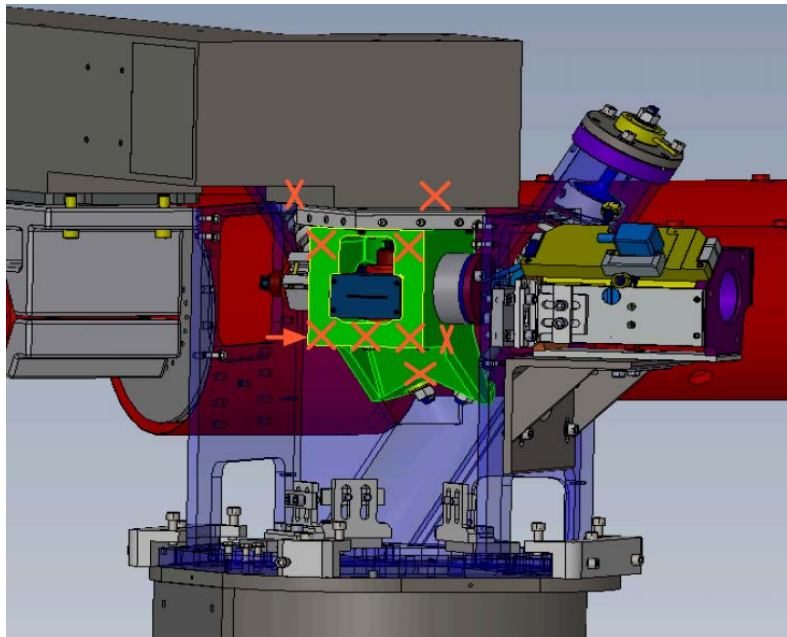

New Modeling at Stanford

- Now that we believe the HEPI system is the source of the issue, see if we can properly model it
- Initial modeling did not include the pier or actuators
- Odd motion not visible, frequency of 4 Hz

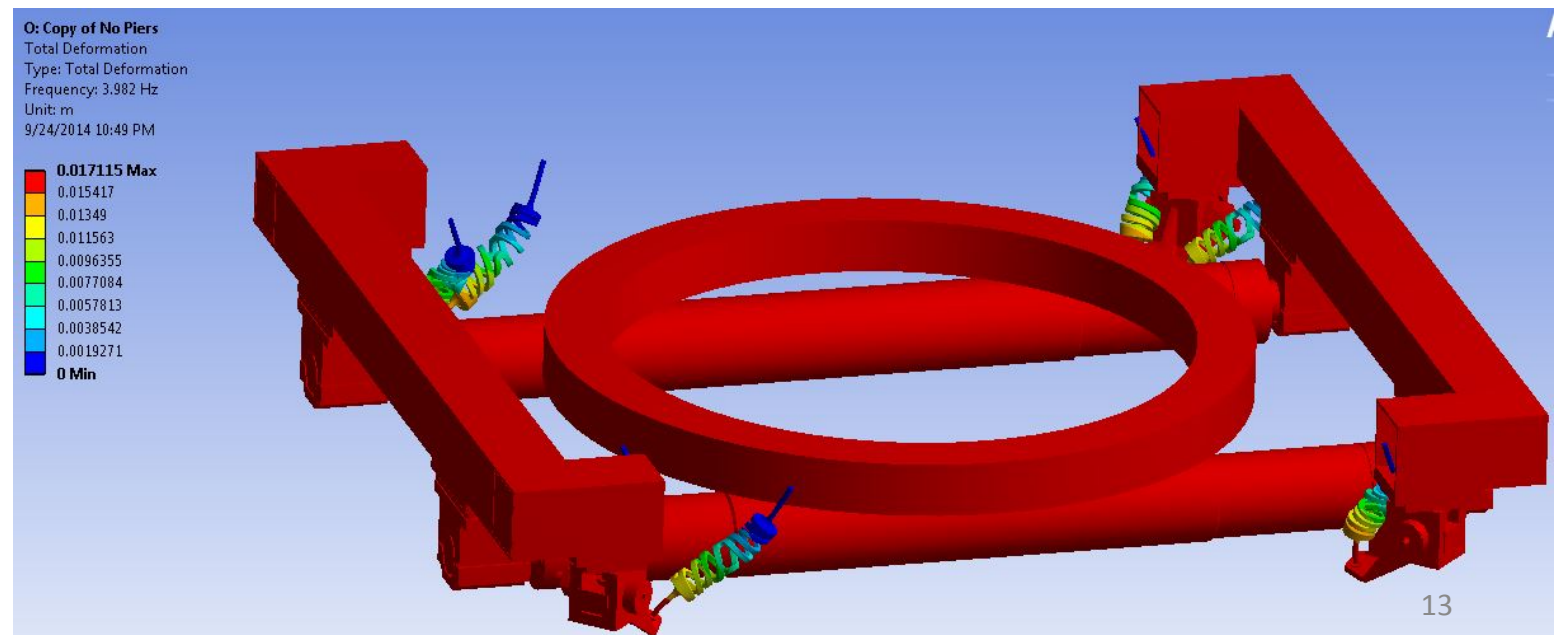

Actuator Addition

- Added actuators based on Brian's old model at 8 Hz
- Frequency more reasonable, still nothing on the foot motion

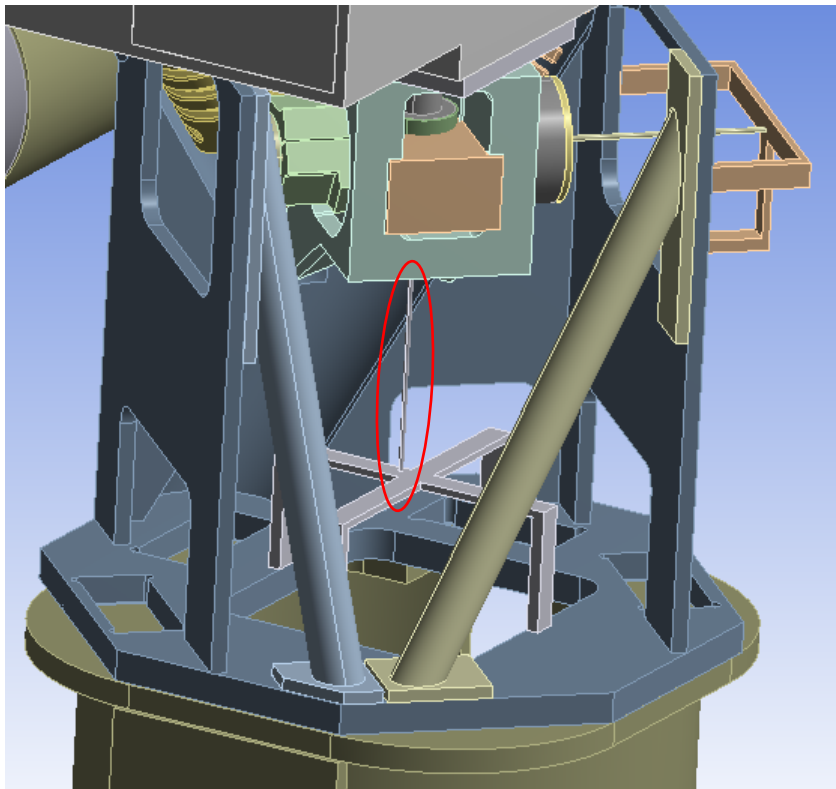

Desired K	1.6e7 N/m
E	1.88e11 Pa
Length	0.25 m
Radius	0.0026 m
New Freq	14.68 Hz

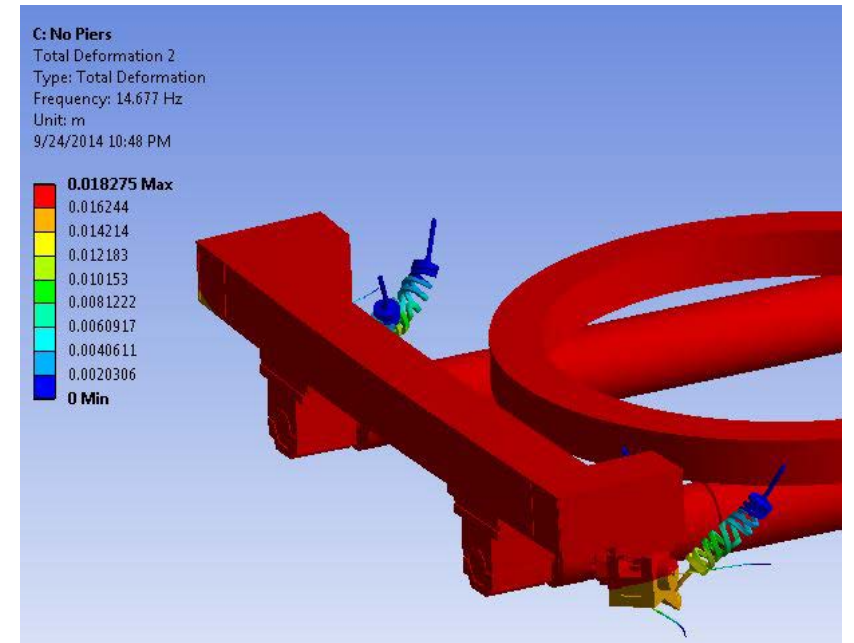

See <https://alog.ligo-la.caltech.edu/SEI/index.php?callRep=543>

Piers and Full Model Setup

- Added piers, attached end of actuators to pier with stiff structures
- Fixed supports at floor

Component	Mass	Material
Piers	750 kg each	Steel
HEPI Housing	160 each	Steel
HEPI Foot	20 kg each	Steel
Crossbeam	480 kg each	Steel
Support Tube Attach	140 kg each	Steel
Support Tubes	460 kg each	Steel
Stage 0	700 kg	Aluminum
Total Mass w/o Piers/Housing	3220 kg	-
Total Mass	7060 kg	-

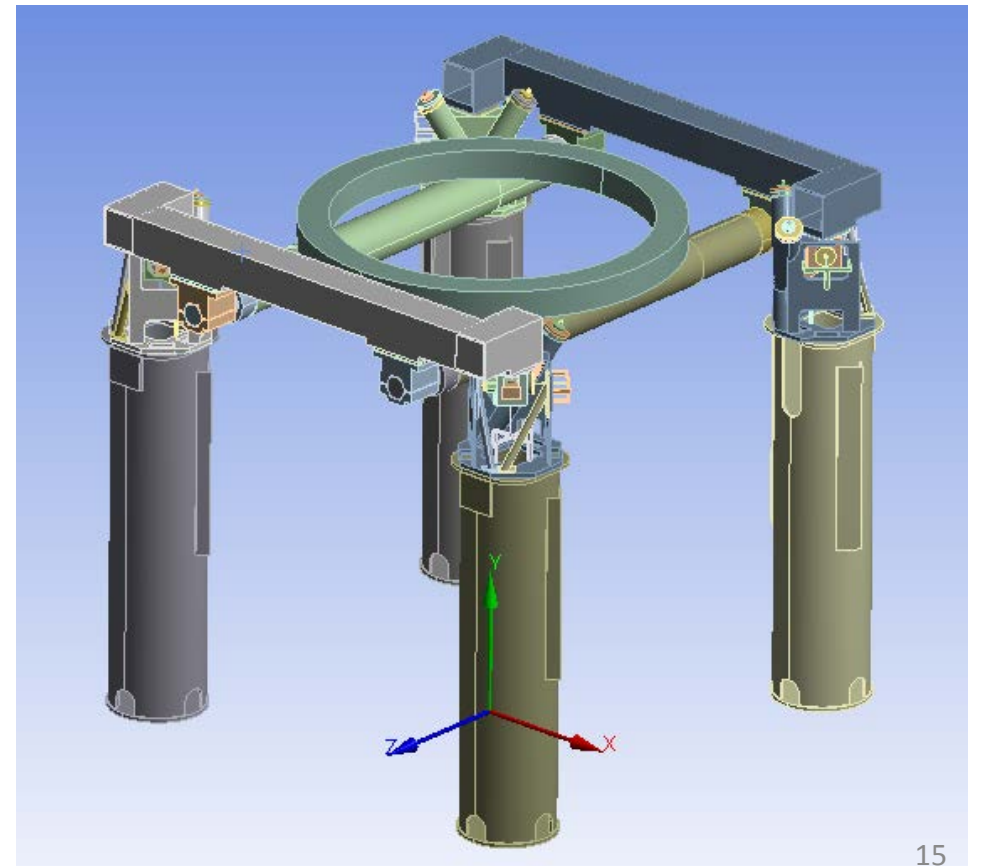

Full Model Results

- Beam tube direction mode at 11.4 Hz

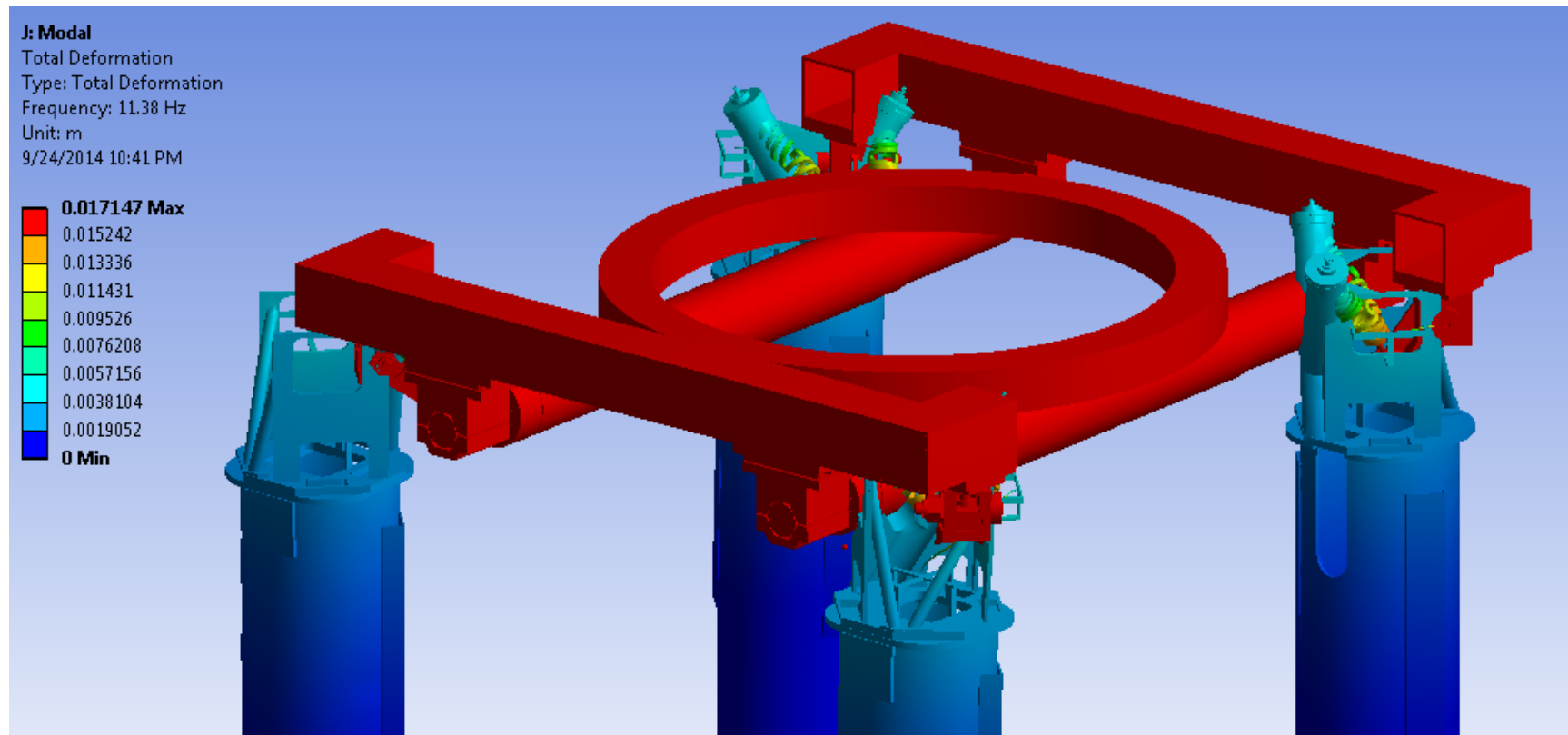

Other Attempts

- Static structural testing at crossbeam and foot
- Response spectra at crossbeam and foot
- No new insight

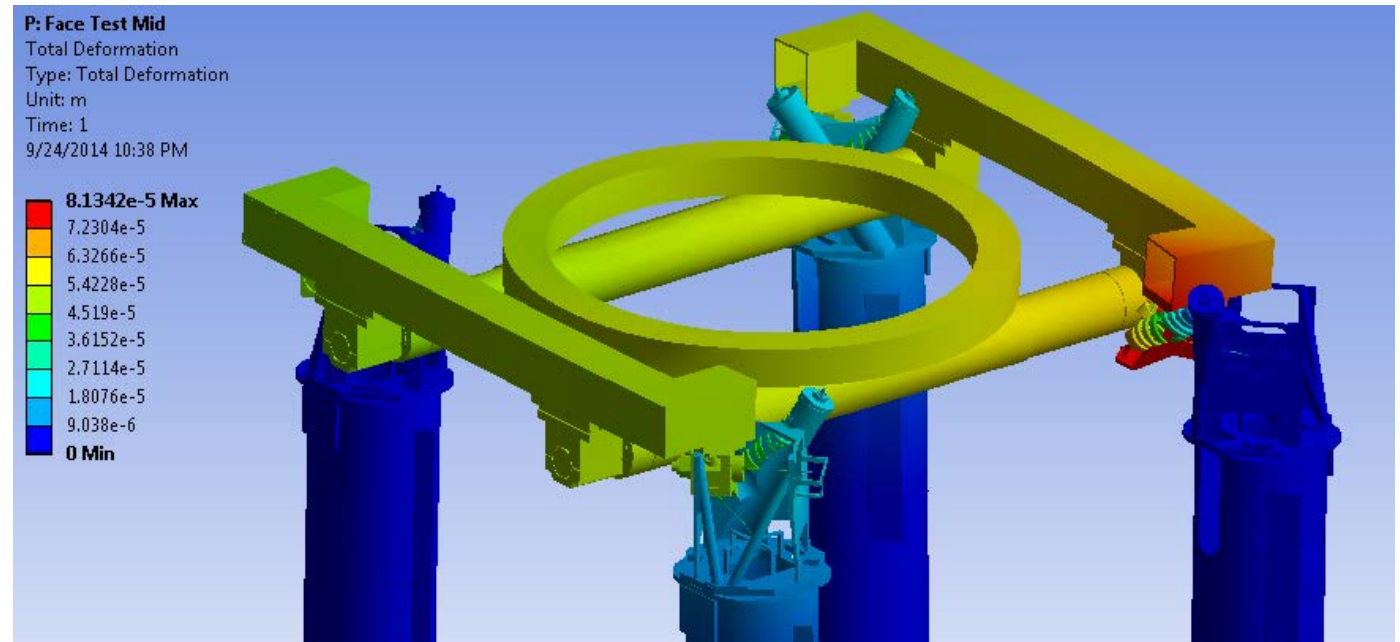
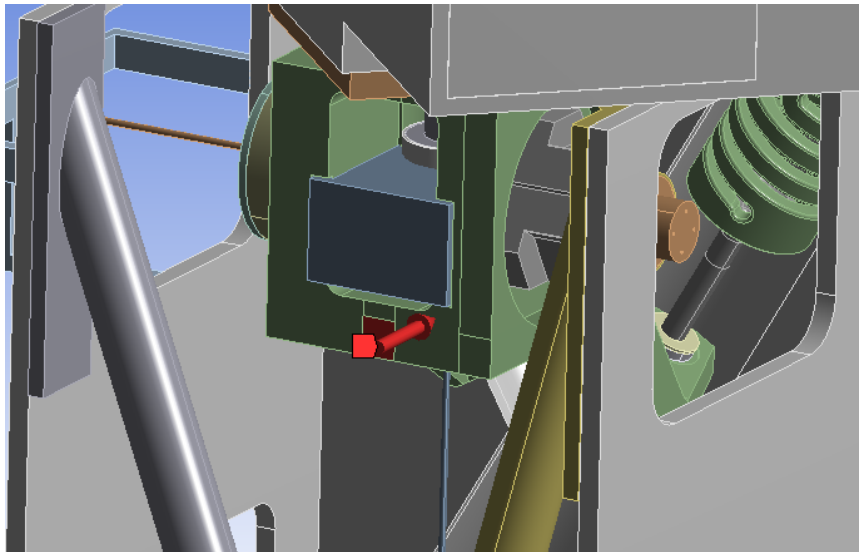

Stiffness Data from Measurements

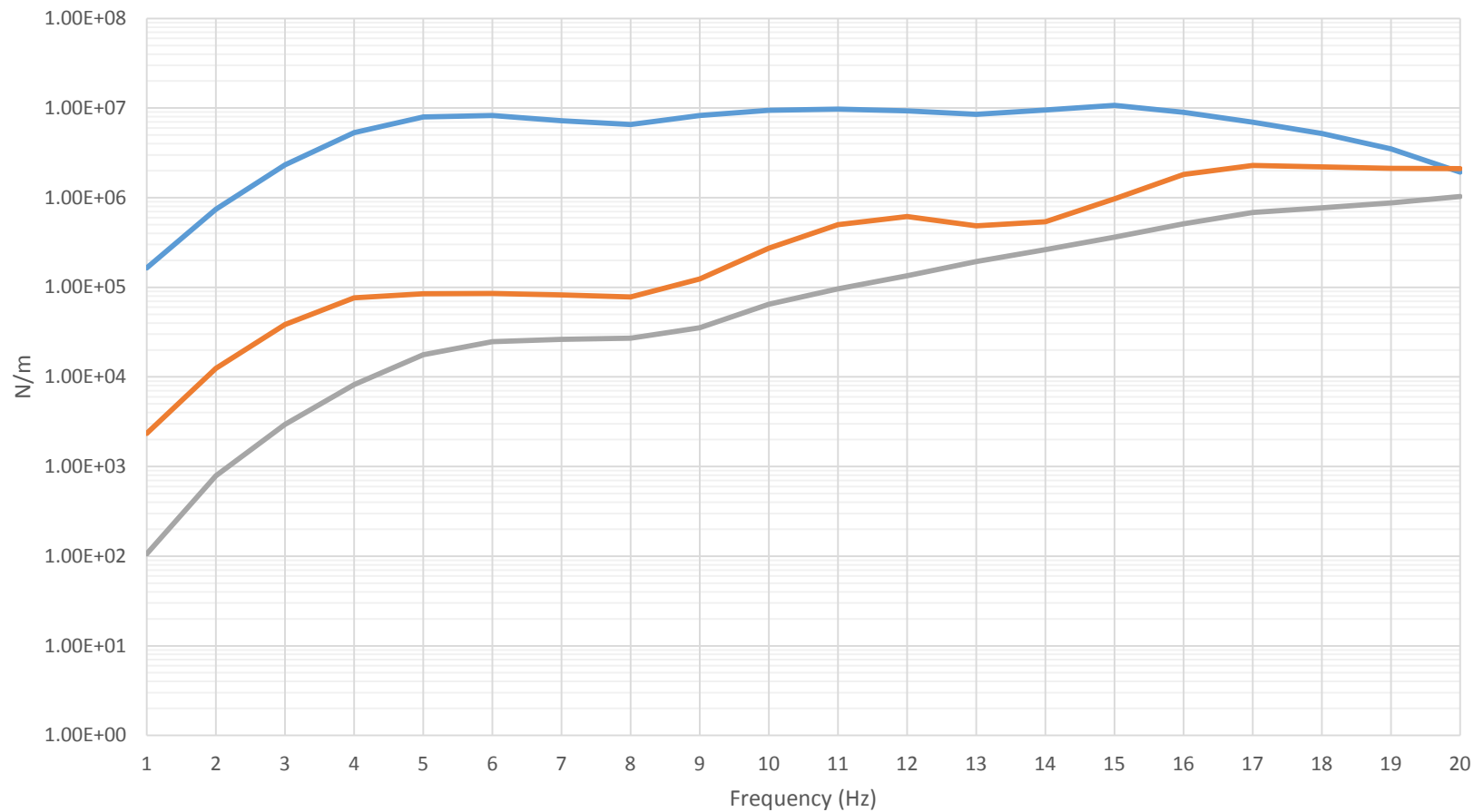

$$\frac{1}{2\pi} \sqrt{\frac{1e7 \text{ N/m}}{3220 \text{ kg}}} = 8.9 \text{ Hz}$$

— Pier
— Crossbeam
— Foot

Coherence above 0.9

Proposed Solutions

- Add another actuator
 - Likely not possible due to space and construction issues
- See if the mode can be controlled with existing actuators
- Replace/modify the crossbeam
- Add vibration absorbers to crossbeam
- Stiffen the piers
- Reaction mass actuator

Next Steps

- Get foot measurement resolved
 - Will determine usefulness of crossbeam modification
- Paper study of controller for 8 Hz mode
 - Can it be controlled with existing system?
- Create models of passive and active damping systems
 - Determine feasibility
- Create model with additional actuator
 - Probably not practical
- Create model with stiffer piers
 - Could make HEPI control simpler

$$\frac{1}{2\pi} \sqrt{\frac{1e7 \text{ N/m}}{3220 \text{ kg}}} = 8.9 \text{ Hz} \quad \rightarrow \quad \frac{1}{2\pi} \sqrt{\frac{4e7 \text{ N/m}}{3220 \text{ kg}}} = 17.7 \text{ Hz}$$

Extra Slides

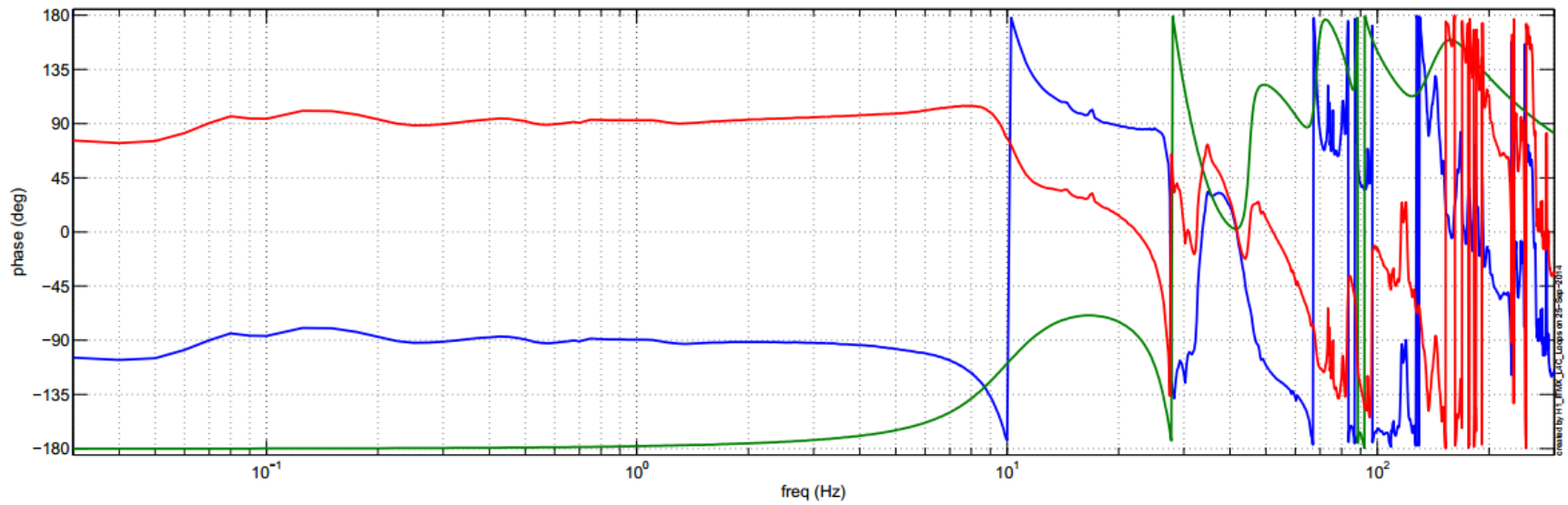
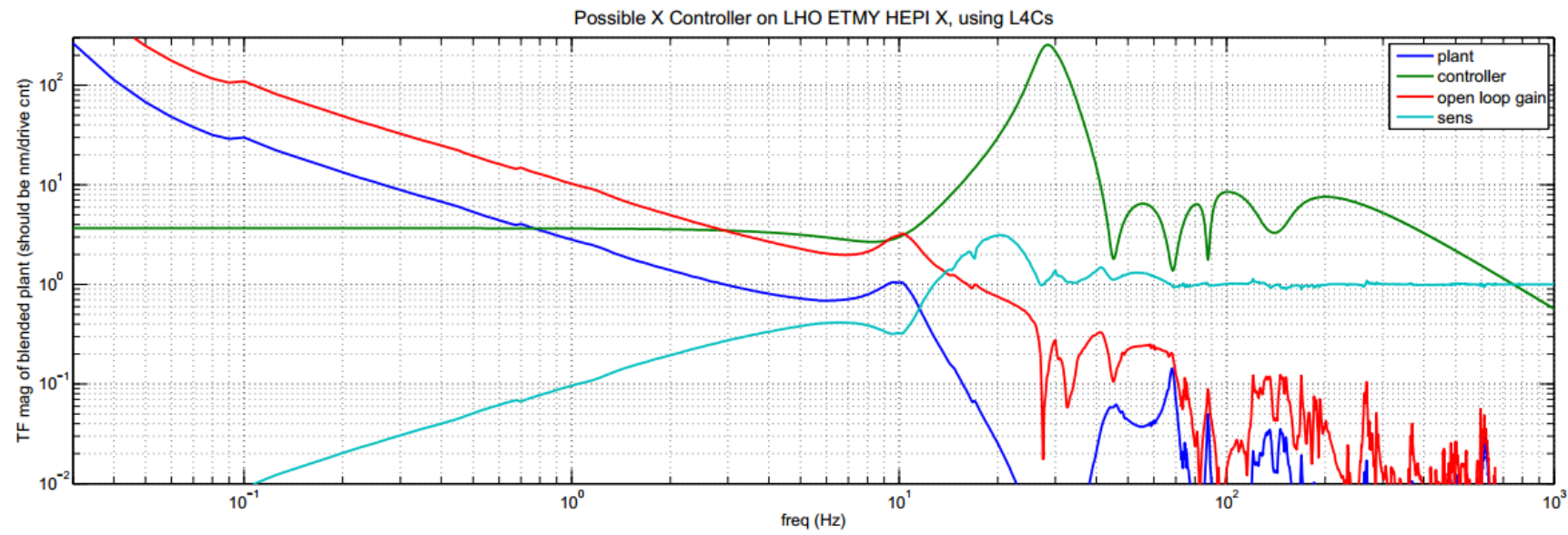

Predicted Effect of Tuned Mass Damper on HEPI's 8Hz peak
various TMD masses, with their ideal Q

