

Transportation of Ultra-Stable Light via Optical Fiber

LIGO SURF 2014: Progress Report 2

Emily Conant

Bard College, Annandale-on-Hudson, NY 12504

Mentor: Evan Hall, Rana Adhikari, Tara Chalermsongsak

Abstract

It has been demonstrated that polarization-maintaining single mode optical fiber can be used to transport frequency-stable light. It is desired to transport stable light to other labs in West Bridge to serve as a frequency reference for various experiments investigating different sources of noise in gravitational-wave detectors. Stable light has been obtained from ultra-stable Fabry-Pérot cavities. We have mode matched stable light into the fiber and are using a double-pass acousto-optic modulator (AOM) configuration to cancel fiber phase noise. We use a beamsplitter to interfere the stable light and double passed light onto a photodiode, which is connected to a phase-locked loop (PLL) to measure the beat frequency. From there, we analyze the noise in the system by measuring the power spectral density of the PLL control signal with a spectrum analyzer. We measured the expected dominant sources of noise in the set up by using a similar PLL set-up and found a large source of noise coming from the AOM driver. This was replaced with a low noise driver and we will proceed to transport the fiber to another lab once we identify and suppress any other possible noise sources.

1 Introduction

LIGO is a signal recycling Michelson interferometer with Fabry Pérot arms. The mirrors of the optical cavities consist of SiO_2 and Ta_2O_5 coatings, which are a dominant source of thermal noise. Other sources of noise include seismic vibrations such as earthquakes and microseisms, photon shot noise and Newtonian gravity noise [1]. At frequencies lower than 10 Hz, seismic noise, environmental disturbances and technical noise sources dominate. Radiation pressure noise, thermal noise from the suspensions and Newtonian gravity noise are the limiting sources in the 10-40 Hz frequency range. At frequencies in the 50-200 Hz range, thermal noise from the mirror optical coatings and quantum effects from the light are limiting noise sources. Above 200 Hz, shot noise from the light become a dominant noise source [2]. The dielectric, thin-film coatings on the test masses experience mechanical dissipation, which causes Brownian noise. Additionally, temperature fluctuations in the coatings are the cause of thermo-optic noise [3]. Pound-Drever-Hall Locking is a technique used to obtain stable light from a laser by locking the laser frequency to stable Fabry-Pérot cavities. Various experiments investigating different noise sources need a stable frequency reference to identify and suppress these noises. Transporting stable light via optical fibers will be explored.

1.1 Thermal Noise

In order to detect gravitational waves, high precision is needed since the space-time distortion effects of the strain are so small. However, at low frequencies, thermal noise becomes a limiting noise source in LIGO. Brownian noise occurs as a result of mechanical dissipation in the system, which is represented by the imaginary part of the Young's Modulus for the material: $E = E_0[1 + i\phi(f)]$ where $\phi(f)$ is the loss angle [4]. Random fluctuations in temperature is the source of thermo-optic noise, which is manifested in two forms. Thermo-refractive noise occurs as a result of the temperature dependence of the refractive index. Thermo-elastic noise occurs as a result of the temperature dependence of the linear expansion coefficient, α , which causes random motions on the surface of mirror [3].

1.2 Fluctuation Dissipation Theorem

In order to calculate thermal noise in a system, the Fluctuation-Dissipation Theorem (FDT) can be applied. Callen and Welton's generalized FDT states that when fluctuations in a system occur, a time-dependent dissipation function can be obtained in which the power spectral density is expressed as: $S_x(f) = \frac{k_B T}{\pi^2 f^2} [Re[Y(f)]]$ where $Y(f) = 1/Z(f)$ is the mechanical admittance and Z is the complex impedance, $Z(f) = F(f)/\dot{x}(f)$, where $F(f)$ and $x(f)$ are the Fourier transforms of the driving force $F(t)$ and the response of the observable, $x(t)$. Various approaches of calculating S_x include normal-mode decomposition, a method proposed by Gonzales and Saulson, which involves calculating $[Re[Z(f)]]$ separately for each normal-mode. An alternate approach proposed by Levin suggests that a small applied force to a system is analogous to random fluctuations. This method requires an oscillatory pressure to be applied, which allows for a relationship between the dissipation and PSD to be obtained: $S_x(f) = \frac{2k_B T}{\pi^2 f^2} \frac{W_{diss}}{F_0^2}$ where $S_x(f)$ is the one-sided power spectral density of the displacement x at a certain frequency f , T is the temperature, k_B is Boltzmann's constant, F_0 is the amplitude of the the applied oscillating force, and W_{diss} is the dissipated power when the oscillating force is applied. This method allows for direct calculation of S_x [4].

1.3 Pound-Drever-Hall Laser Frequency Stabilization

It is essential to have frequency stabilized light in order to make precise measurements with gravitational-wave detectors and use of stable light as a reference allows for identification of noise in a system. The Pound-Drever-Hall technique involves locking light emitted by a laser to a stable Fabry-Pérot cavity to stabilize the frequency of this light. Fabry-Pérot cavities can be used to measure the frequency of a laser beam by examining how much light is transmitted or reflected. Light that is an integer number times the free spectral range of the cavity, which is dependent on the length of the cavity is transmitted. If the cavity is perfectly resonant, then the laser frequency is indeed an integer number times the free spectral range. If this is not the case, some light will be reflected off the cavity. However, there will always be some reflected light unless the following two conditions are met: (1) the cavity mirrors have identical reflectivity, and (2) the spatial mode of the laser beam is perfectly matched to the mode of the cavity, which means it is entirely TEM₀₀, has the correct waist at the correct position, and the axis of the laser beam is the same as the axis

of the cavity. In the case that the laser frequency is perfectly resonant with the cavity, the two beams destructively interfere since the reflected beam and light from the standing wave inside the cavity that is leaked through the mirror are 180 degrees out of phase with each other. If the reflected beam and leakage beam do not completely cancel each other out, which means the light is not perfectly resonant with the cavity.

The phase of the reflected beam must be measured in order to determine whether or not the laser is perfectly resonant with the cavity. A phase modulator can be used in which the sidebands produced are interfered with with the reflected beam, thus producing a beat pattern. From this beat pattern, the phase of the reflected beam can be determined with a photodetector. The signal from the photodetector passes through a mixer in which the RF signal is mixed with the same waveform that is used to drive the phase modulator. If the local oscillator (LO) port of a mixer is driven with $\cos(\omega_1 t)$ and the radio frequency (RF) port of the mixer is driven with $\cos(\omega_2 t)$, then the intermediate frequency (IF) port will be proportional to:

$$\cos(\omega_1 t) \cos(\omega_2 t) = \frac{\cos[(\omega_1 + \omega_2)t] + \cos[(\omega_1 - \omega_2)t]}{2}.$$

In the CTN experiment, the LO port, which generates signal from the sidebands and RF port, which generates signal from the photodiode voltage, are sinusoids with frequency Ω_m where $\Omega_m/2\pi = 14.75$ MHz. The mixer gives the components at the sum and difference, $\Omega_m + \Omega_m = 2\Omega_m$ and $\Omega_m - \Omega_m = 0$. After the signal passes through the low-pass filter, the sum component is removed since the error signal is contained in the difference term. Examining the error signal will determine whether or not the laser is resonant with the cavity [5].

2 Work Completed

The cavity light from the CTN experiment is known to be stable, having a beat note of $(0.5 \text{ Hz})/f^{1/2}$ from 10 Hz to 1 kHz. This experiment contains two separate cavities, each with their own stabilized laser. The beams from the two lasers are interfered on an RF photodiode, which produces a beat note. The power spectral density of the frequency noise of the beat note is measured with a spectrum analyzer. Since the laser frequency noise is stable in this experiment, it can be used as a frequency reference for a number of of labs conducting various experiments including investigation of noises in gravitational-wave detectors. That being said, coupling the cavity light into optical fibers that lead to other labs is a goal of this project. Optical fibers are extremely sensitive to environmental perturbations, which generates phase noise. It has been demonstrated that phase modulators, specifically acousto-optic modulators, can be used as a method of phase-noise cancellation. A phase-locked loop (PLL) is used to read out the frequency fluctuation of light returning from the fiber.[6].

2.1 Initial Setup

First, we created a table top experiment to prove that transporting stable light via optical fiber can be done. The goal of this setup was to measure the noise in the system and create a noise budget to identify and suppress possible disturbances. We installed various optics

on the table for the fiber phase noise measurement. Light passes through the Pre-mode Cleaner (PMC), a half wave plate, Faraday isolator, so that the light is transmitted in one direction. The light then goes through a lens, another half wave plate, an electro-optic Modulator (EOM), Electro-optic Amplitude Modulator (EOAM), another half wave plate and then through a polarizing beamsplitter (PBS). Light is reflected off the beamsplitter and directed toward lenses and a steering mirror and is then directed into the fiber input. The round trip length of the PMC is 42 cm and the radius of curvature of the concave mirror is 1 m. Using the formula $w_0^2 = \frac{\lambda}{2\pi} \sqrt{d(2R - d)}$, we found that a waist of 370 microns coming out of the PMC. Since we wanted a waist of 50 microns going into the fiber input, we calculated the proper lenses needed as well as the distances in which they should be placed from each other. The first beam following the PBS has a focal length of 124 mm and lens 3 with a focal length 250 mm. Between the two lenses is a mirror, which is tilted at a 45 degree angle to guide the light from lens 2 to lens 3. Lens 2 and Lens 3 are roughly 2 inches away from each other.

A fiber coupler was placed 4 inches away from the second lens so that a 50-micron waist occurs at the input of the fiber. Following the fiber output, which has a waist of 50 microns, we calculated the proper lens to use as well as the proper distance to place the objects so that we would have a waist of approximately 150 microns going into the Acousto-optic Modulator (AOM). Roughly 3.5 inches from the fiber output, we placed a lens with focal length of 50.2 mm and a half wave plate followed by an AOM. After the light passes through the AOM, we placed another lens that yields a waist at the mirror placed at the end of this setup. The light is then reflected back, so it double passes the AOM, and then passes back through the fiber. The returning light goes through a 50/50 beam splitter and is guided to the photodetector, so that a beat frequency measurement can be done. In this setup, there was 1.6 mW of power going into the fiber, 342 μ w, which yields a 20% efficiency.

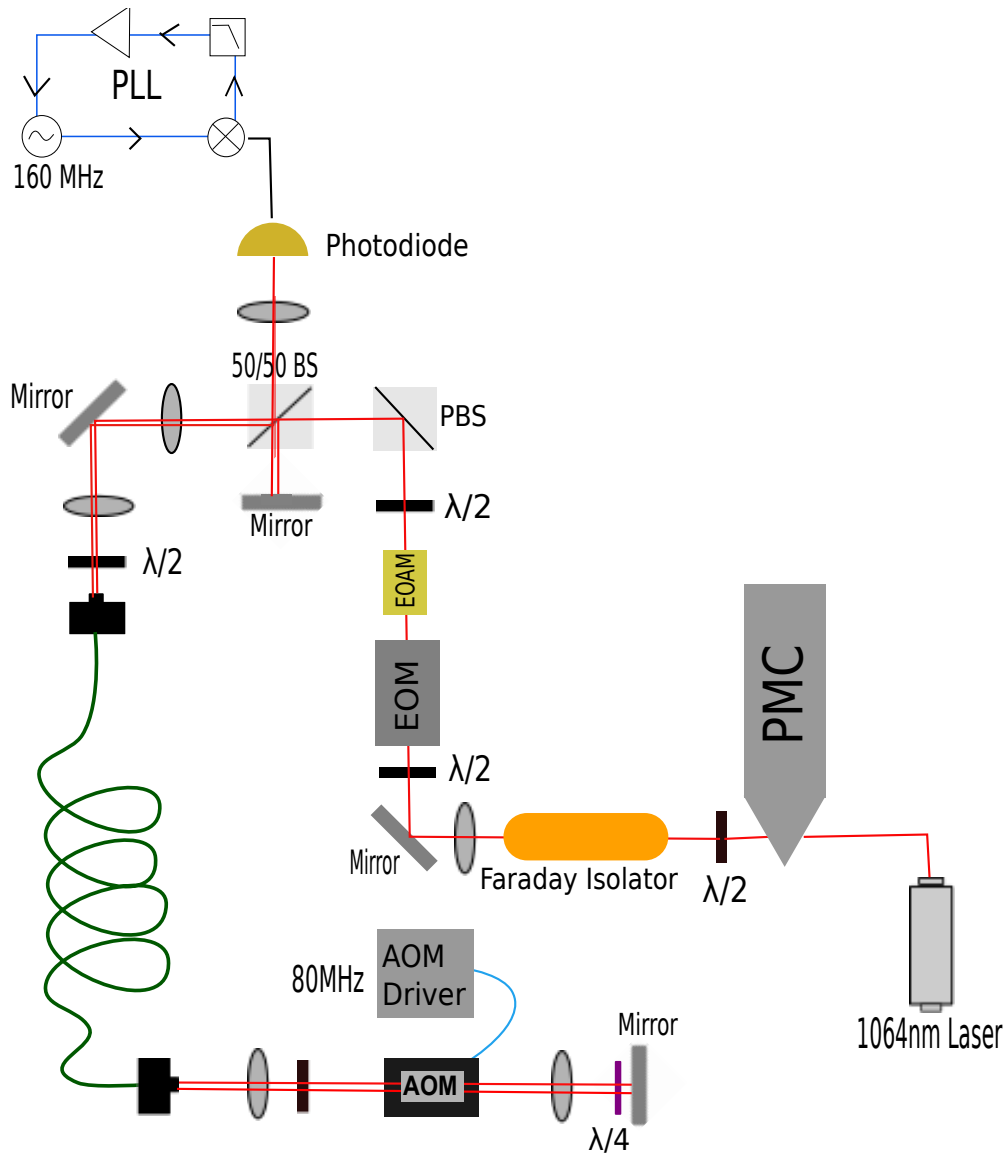

Fig 1. Table top set up for measuring fiber phase noise. The photodetector is connected to a phase-locked loop (PLL) to read the beat frequency, which gives fiber phase-noise information.

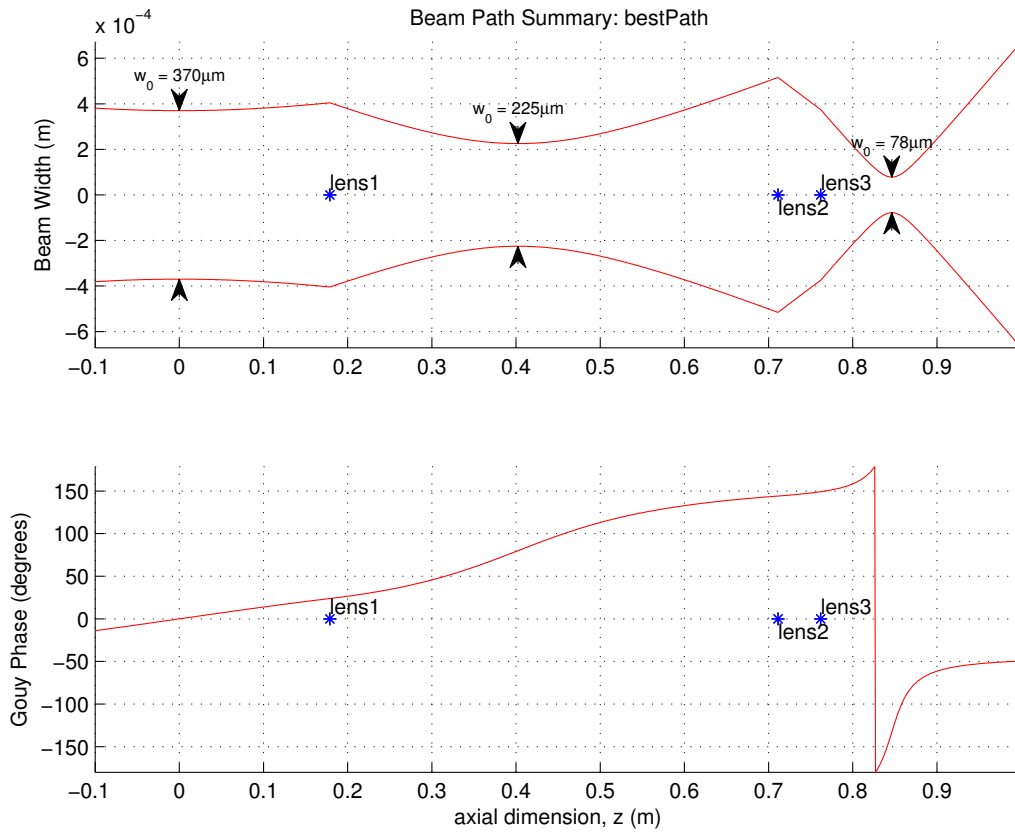

Fig 2. With a waist of approximately 370 microns coming out of the PMC, two lenses were placed roughly 2 inches away from each other along with a steering mirror to send light into the fiber at roughly 50 microns.

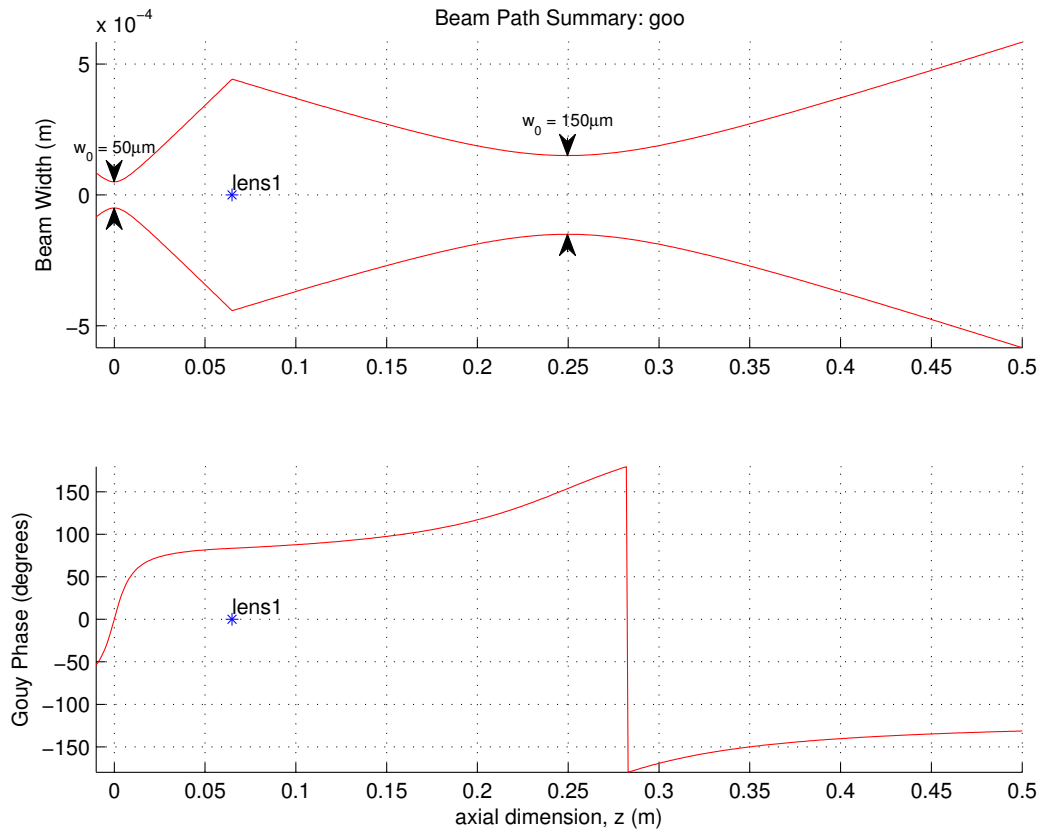

Fig 3. At the fiber output, a waist of approximately 50 microns is coming out and a waist of 150 microns going into the AOM is desired, so the proper lens of focal length 50.2mm and 3.5 inches away from the output was placed down onto the table.

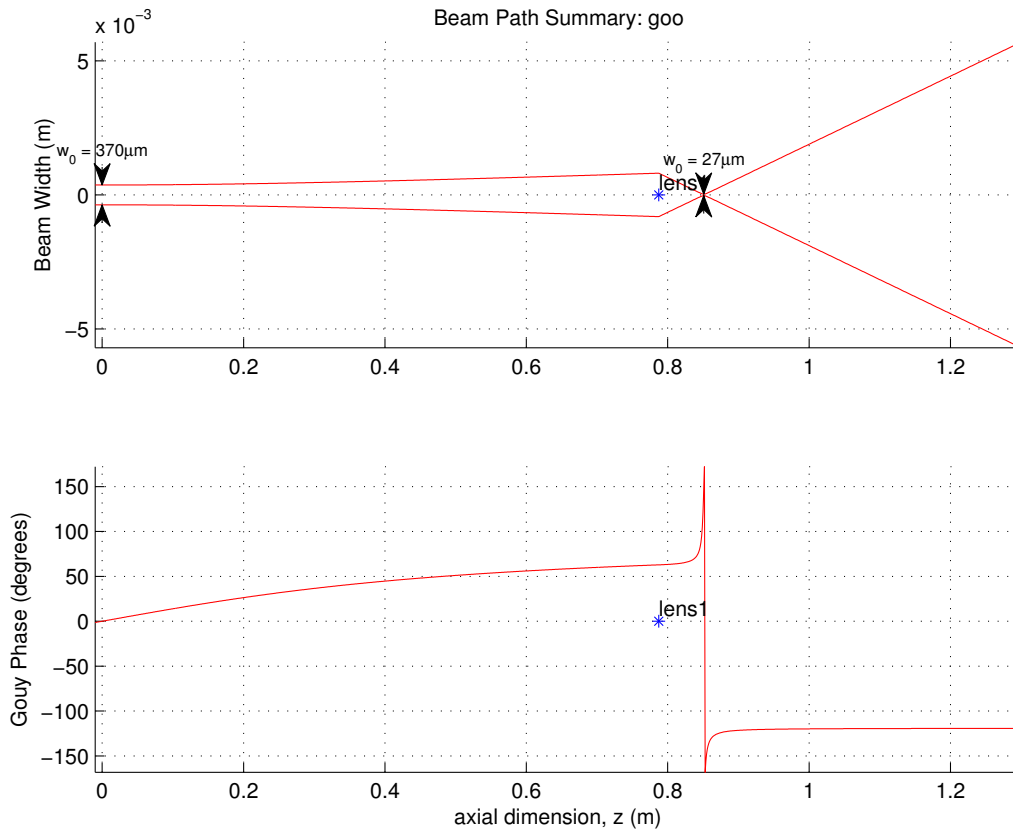

Fig 4. After the beam from the PMC goes through the PBS, it goes through a 50/50 beamsplitter where some light is reflected onto a mirror and then passes through the RF photodiode. It is required that the beam spot size is 1/3 the diameter of the photodetector. A lens with a focal length of 33 mm was placed on the table at the appropriate distance, which gives a waist of 27 microns. The RF photodiode was placed past the 27 microns waist point, so there would be a beam with a radius of approximately 50 microns going into the detector.

2.2 Noise Budget

We looked at the beat signal of the reflected beam and the beam that is double-passed through the AOM onto the photodiode with an oscilloscope. The first beam had a power of $813 \mu\text{w}$ and beam that is double-passed through the AOM had a power of $10 \mu\text{w}$. The voltage of the beat signal fluctuated between -24 dBm and -13 dBm, which hinted that something in the setup was creating noise. A PLL was used to lock the frequencies. We used the IFR/Marconi 2023A signal generator and a SR560 low noise voltage preamplifier. The Marconi had a carrier frequency of 160 MHz, an RF level of 13.0 dBm, and FM dev of 10KHz. The FM modulation coefficient is $\frac{10}{\sqrt{2}}$ kHz/V. The gain on the SR 560 was 200 V/V. The SR560 corresponds to the amplifier in the PLL of figure 1. We locked the Marconi to the optical beat note. Once the frequencies were locked, we measured the PSD of the PLL control signal and open loop transfer function with a spectrum analyzer.

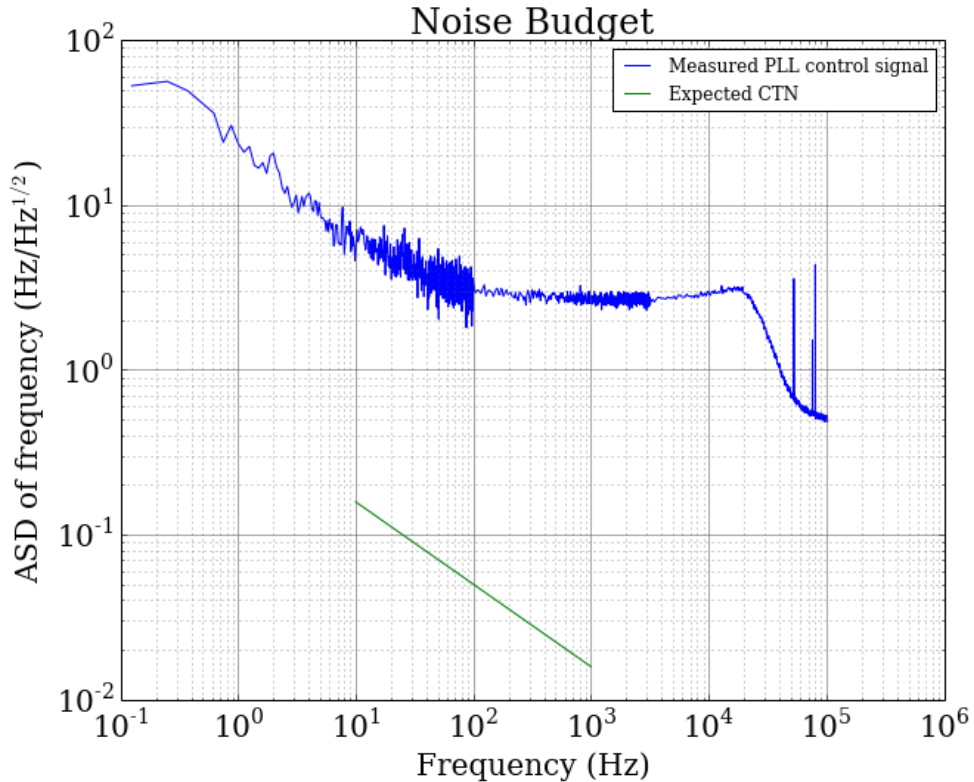

Fig 5. Measurement of the the PLL control signal in the initial setup

2.3 AOM Driver Noise

After obtaining a PSD measurement of the PLL control signal in the setup, we proceeded to measure the noise of individual components in the setup. We suspected that a large amount of noise was coming from the AOM driver (Crystal Technologies 1080AF-AIF0-2.0 S/N 10351), so we made a PLL to measure the phase noise (figure 6). We used the IFR/Marconi 2023A, the SR560, Mini-Circuits Frequency Mixer ZX05-1MHW-S+-0.5-600MHz, Mini-Circuits 15542 BLP-5+ Low Pass Filter 50 Ohm DC-5MHz, and the Stanford Research Systems Model SR560- Low Noise Pre-amplifier with a gain of 500 V/V. The AOM driver was connected to the Stanford Research Systems-Model DS345 30 MHz Synthesized Function Generator with a DC offset of .7 Volts and the TENMA Laboratory DC Power Supply 72-2080 with a current of .5 Amps and voltage of 28 Volts. The AOM driver output had a 10 dB heatsink attenuator followed by a Mini-Circuits 50 ohm-31030 15542 VAT-9+ 9dB attenuator and another Mini-Circuits 50 ohm-30727 15542 VAT-10+ 10 dB heatsink attenuator, which was connected to the RF port of the mixer. Once we locked the frequencies of the driver and the Marconi, we measured the PLL control signal and open loop transfer function with an FFT analyzer (figure 10).

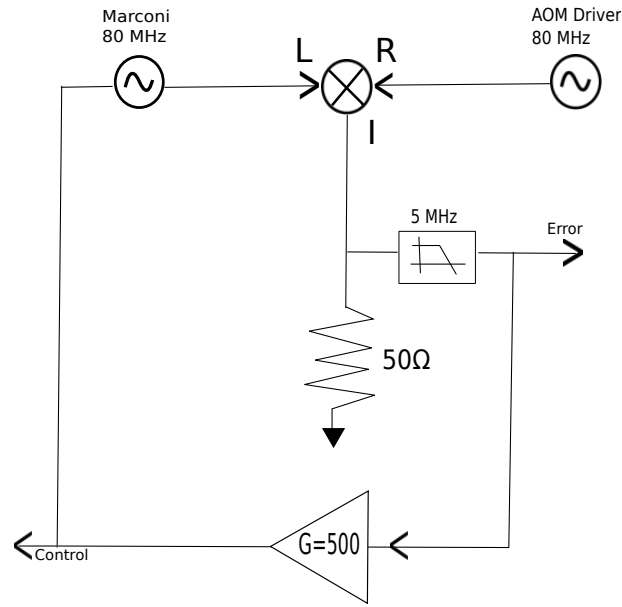

Fig 6. PLL setup for measuring the AOM driver noise

2.4 Marconi Noise

To verify whether or not the noise was from the AOM driver, we measured the noise in the Marconi. We set up a PLL to do this measurement (figure 7), which was exactly the same as the PLL used to measure the driver noise, but we replaced the AOM driver with the Marconi. We used the IFR/Marconi 2023A, the SR560, Mini-Circuits Frequency Mixer ZX05-1MHW-S+-0.5-600MHz, Mini-Circuits 15542 BLP-5+ Low Pass Filter 50 Ohm DC-5MHz, and the Stanford Research Systems Model SR560- Low Noise Pre-amplifier with a gain of 500 V/V. We connected another Marconi to the RF port of the mixer. Marconi 1 had a carrier frequency of 80 MHz, an RF level of 13 dBm and FM dev set to 1 KHz Ext. DC. The second Marconi that we used had a carrier frequency of 80 MHz, an RF level of 2 dBm to match that of the AOM driver and FM dev disabled to prevent noise. Once we locked the frequencies of the the two Marconis, we measured the PLL control signal with an FFT analyzer to obtain a measurement for the Marconi noise (figure 10).

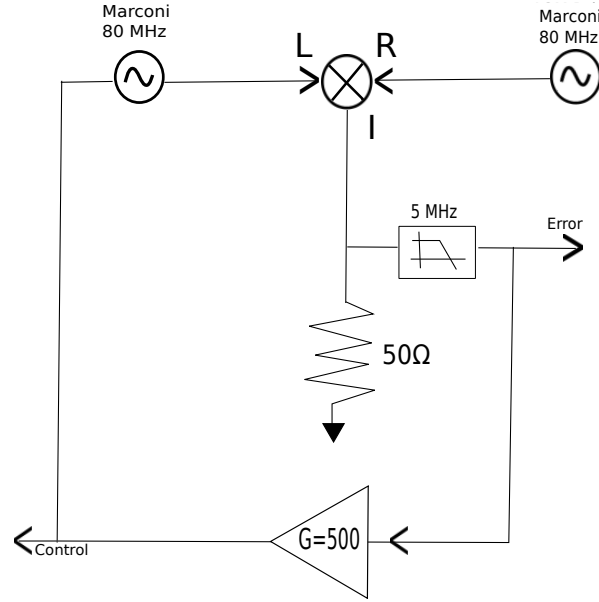

Fig 7. PLL setup for measuring noise in the Marconi

2.5 PSL VCO Driver Noise

To measure the noise of the PSL VCO driver, we used the same PLL set-up from previous noise measurements. The PLL consisted of the following: IFR/Marconi 2023A, the SR560, Mini-Circuits Frequency Mixer ZX05-1MHW-S+-0.5-600MHz, Mini-Circuits 15542 BLP-5+ Low Pass Filter 50 Ohm DC-5MHz, and the Stanford Research Systems Model SR560- Low Noise Pre-amplifier with a gain of 200 V/V. In this case, the gain was set to be lower than before because the PLL would not lock otherwise. We connected another VCO to the RF port of the mixer. The Marconi had a carrier frequency of 80 MHz, an RF level of 13 dBm and FM dev set to 1 KHz Ext. DC.

We connected the VCO to a power supply by hooking up a 9-pin dsub breakout box into the VME interface. The VCO driver needs 24V from the power supply. From opening up the VCO box, and referring to LIGO document D980401-x0, we found that there are three test points in the VME interface: TP1, TP2 and TP3. TP1 corresponds to -24V, TP2 corresponds to +24V and TP3 is ground. Additionally, we needed to figure out what pins to hook up the positive, negative and ground cables onto the breakout box. +24 V corresponds to pins 9 and 4, -24 V corresponds to pin 5 and ground corresponds to pins 8 and 3. There are also two switches that need to be connected to the ground in order for the driver to function properly. The test switch, which corresponds to pin 1 and the wide switch, which corresponds to pin 6 are both connected to pin 3 (ground). The breakout box configuration is displayed in figure 8. We supplied the driver with +/- 24 V with a TENMA Laboratory DC Power Supply 72-2080. We locked the frequencies of VCO driver to the Marconi and measured the PLL control signal and open loop transfer function iwth an FFT analyzer. The measurement of the VCO driver noise is shown in figure 10.

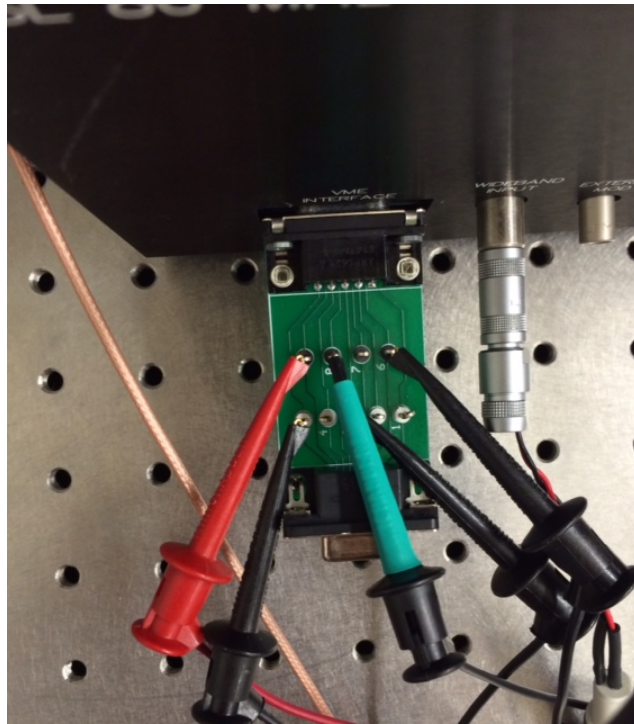

Fig 8. Breakout box configuration to connect the VME interface to a power supply

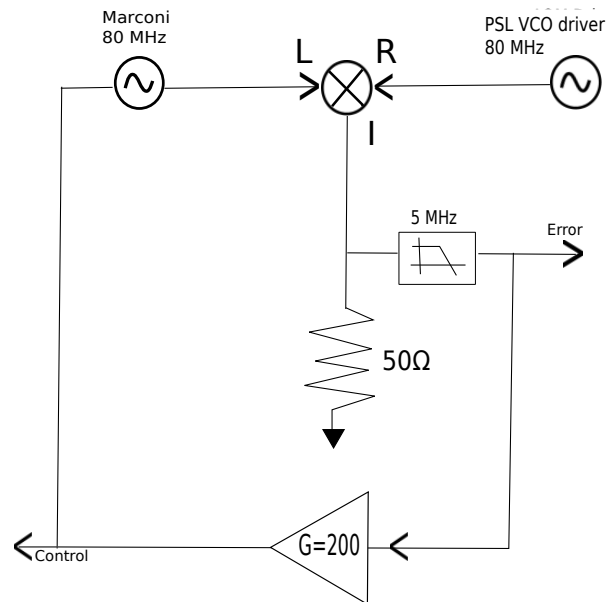

Fig 9. PLL setup for VCO driver noise

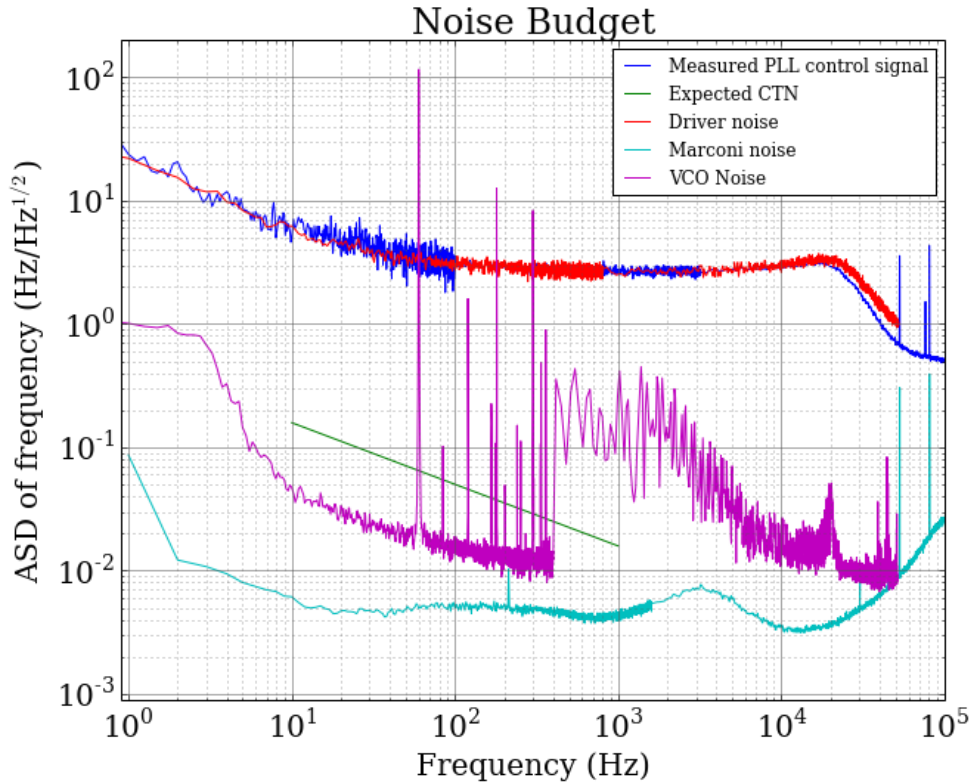

Fig 10. Measured PLL control signal of VCO driver

After collecting several measurements of expected sources of noise, we could see that the Crystal Technologies AOM driver was creating a large amount of noise. We replaced the noisy driver and will proceed to drive the AOM with the VCO driver since it is low noise.

3 Work in Progress/Future Work

Currently, we are working on optimizing mode-matching into the fiber in order to get as much power efficiency as possible. The two lenses before the fiber input were replaced with lenses of focal length 125 mm and 50mm. Currently there is 500 μw of power coming out of the fiber, which is an improvement from before.

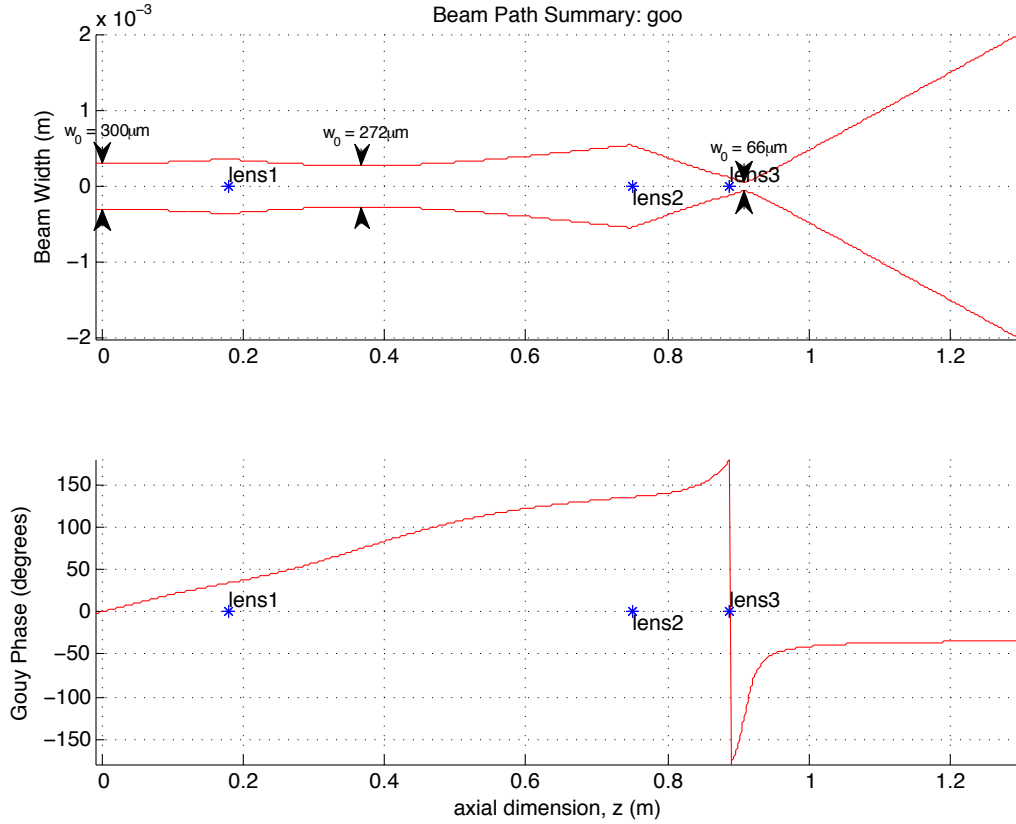

Fig 11. Mode-matching solutions for new lens placement yields a waist of 66 microns going into the fiber

3.1 AOM Fiber Phase Noise Cancellation Scheme

As stated before, AOMs can be used as a method of cancelling fiber phase noise. We have developed two configurations for cancelling fiber phase noise. The first scheme only uses one AOM, whereas the second scheme uses two AOMs.

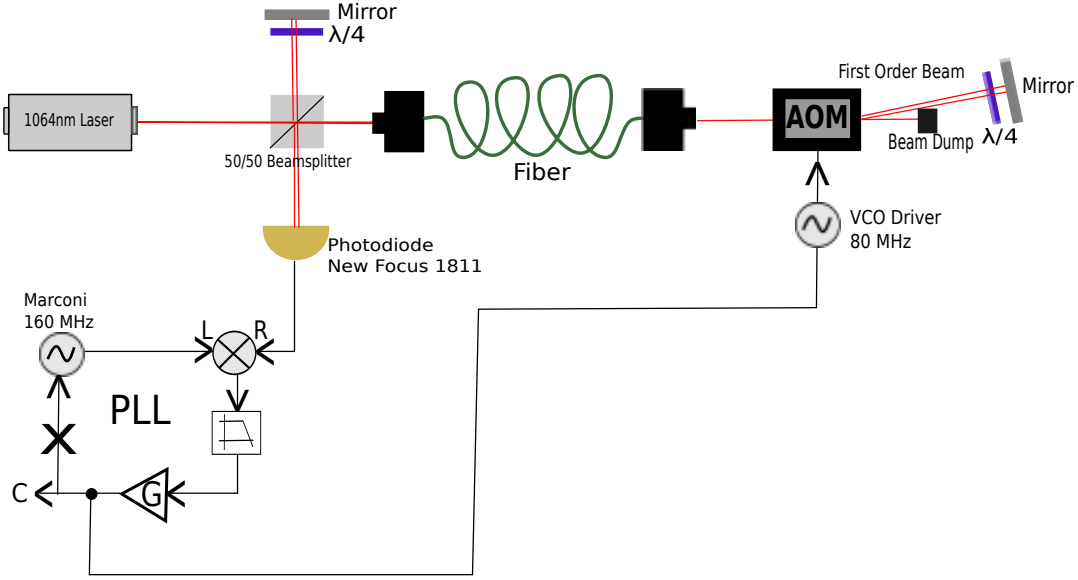

Fig 12. In scheme 1, the optical beat note is locked to the Marconi in order to obtain stable light.

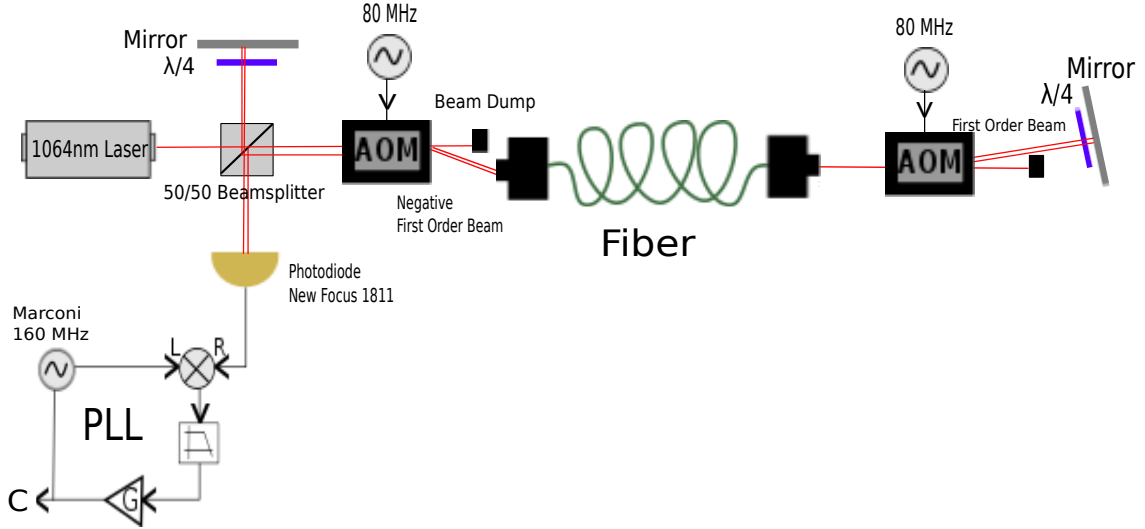

Fig 13. In scheme 2, the first AOM is modulated so that the negative first order beam goes into the input of the fiber and the second AOM is modulated so that the first order beam emerges and is reflected back from a mirror and double passed through both AOMs. We have the initial frequency of light, ω_o , the driver frequency, ω_d , the modulation frequency, ω_m and fiber phase shift $e^{i\phi(t)}$. Prior to entering AOM1, the light coming through is $E_o e^{i\omega_o t}$. After passing through AOM 1, we have $E_o e^{i\omega_o t} e^{-i\omega_d t} e^{-i\omega_m t}$. The light passes through the fiber and we obtain $E_o e^{i\omega_o t} e^{-i\omega_d t} e^{-i\omega_m t} e^{i\phi(t)}$. Next, the light goes through AOM2 and we get $E_o e^{i\omega_o t} e^{-i\omega_d t} e^{-i\omega_m t} e^{i\phi(t)} e^{i\omega_d t} e^{i\omega_m t}$. The light is then double passed through both AOMs and the result should be: $E_o e^{i\omega_o t} e^{-2i\omega_d t} e^{-2i\omega_m t} e^{2i\phi(t)} e^{2i\omega_d t} = E_o e^{i\omega_o t - 2i\omega_d t - 2i\omega_m t + 2i\phi(t) + 2i\omega_d t} = E_o e^{i\omega_o t}$.

Currently, we are setting up the configuration involving one AOM. The laser light goes through a 50/50 beamsplitter, where light is reflected onto the photodiode and the rest of

the light is transmitted through the fiber. Then the light is double passed through the AOM, comes back through the fiber, hits the beamsplitter, and is reflected onto the photodiode. We will look at the beat frequency of the two beams and will lock the AOM driver and Marconi in order to take a measurement of the PLL control signal. If the data shows that this configuration produces stable light, we will proceed to transport the fiber to gyro lab.

4 References

- [1] R. Adhikari, “Gravitational Radiation Detection with Laser Interferometry,” *Rev. Mod. Phys.*, 2014.
- [2] Harry et al., “Advanced LIGO: The Next Generation of Gravitational Wave Detectors,” *Class. Quantum Grav.*, vol. 27, 084006, 2010.
- [3] R. Nawrodt, “Challenges in thermal noise for 3rd generation of gravitational wave detectors,” *Gen. Relativ. Gravit.*, 2011.
- [4] Yu. Levin, “Internal thermal noise in the LIGO test masses: A direct approach,” *Phys. Rev. D* 57, 659.
- [5] Eric D. Black, “An Introduction to Pound-Drever-Hall Laser Frequency Stabilization,” *American Journal of Physics* 69-79, 2001.
- [6] Long-Sheng Ma, Peter Jungner, Jun Ye, and John L. Hall, “Delivering the Same Optical Frequency at Two Places: Accurate Cancellation of Phase Noise Introduced by an Optical Fiber or Other Time-Varying Path,” *Optics Letters*, Vol. 19, No. 21, 1994.