

# Quantization Noise in Advanced LIGO Digital Control Systems

Ayush Pandey

Mentors: Christopher Wipf, Jameson  
Graef Rollins, Rana Adhikari



# Project Introduction

- Mixed Signal Systems
- Digital Control vs Analog Control
- Quantization Noise: One of the major demerits of Digital Control Systems
- Causes of Quantization Noise

# Quantization Noise

In Analog:  $1.25 + 2.34500000199999 = 3.59500000199999$

In double precision computer,  
 $(1.25) + (2.34500000199999) = 3.5950000012$

Quantization Noise = (approximately)  $10^{-12}$

Similarly, two  $(B+1)$  bit numbers, on multiplication give a  $(2B+1)$  number which then needs to be truncated for a  $B+1$  precision computer

# Digital Control System : I

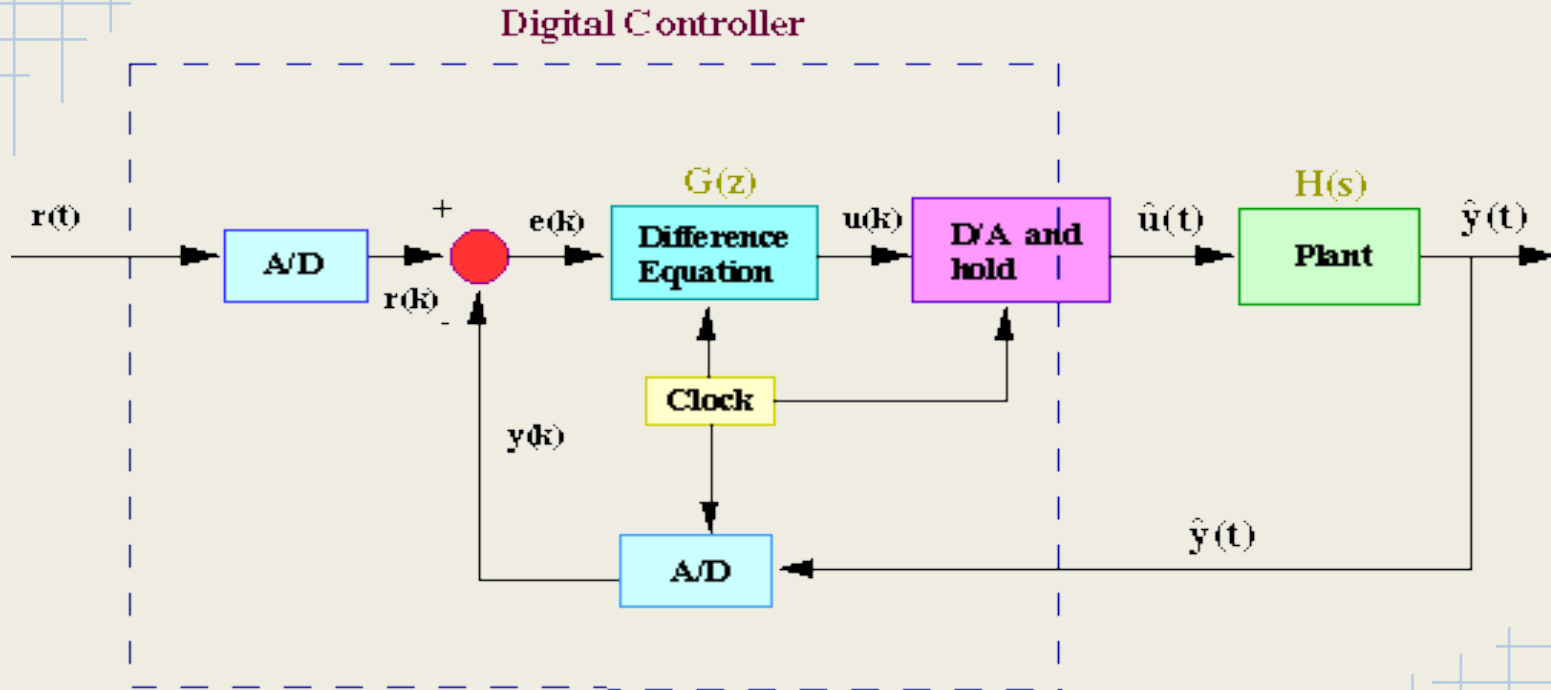

# Digital Control System : II

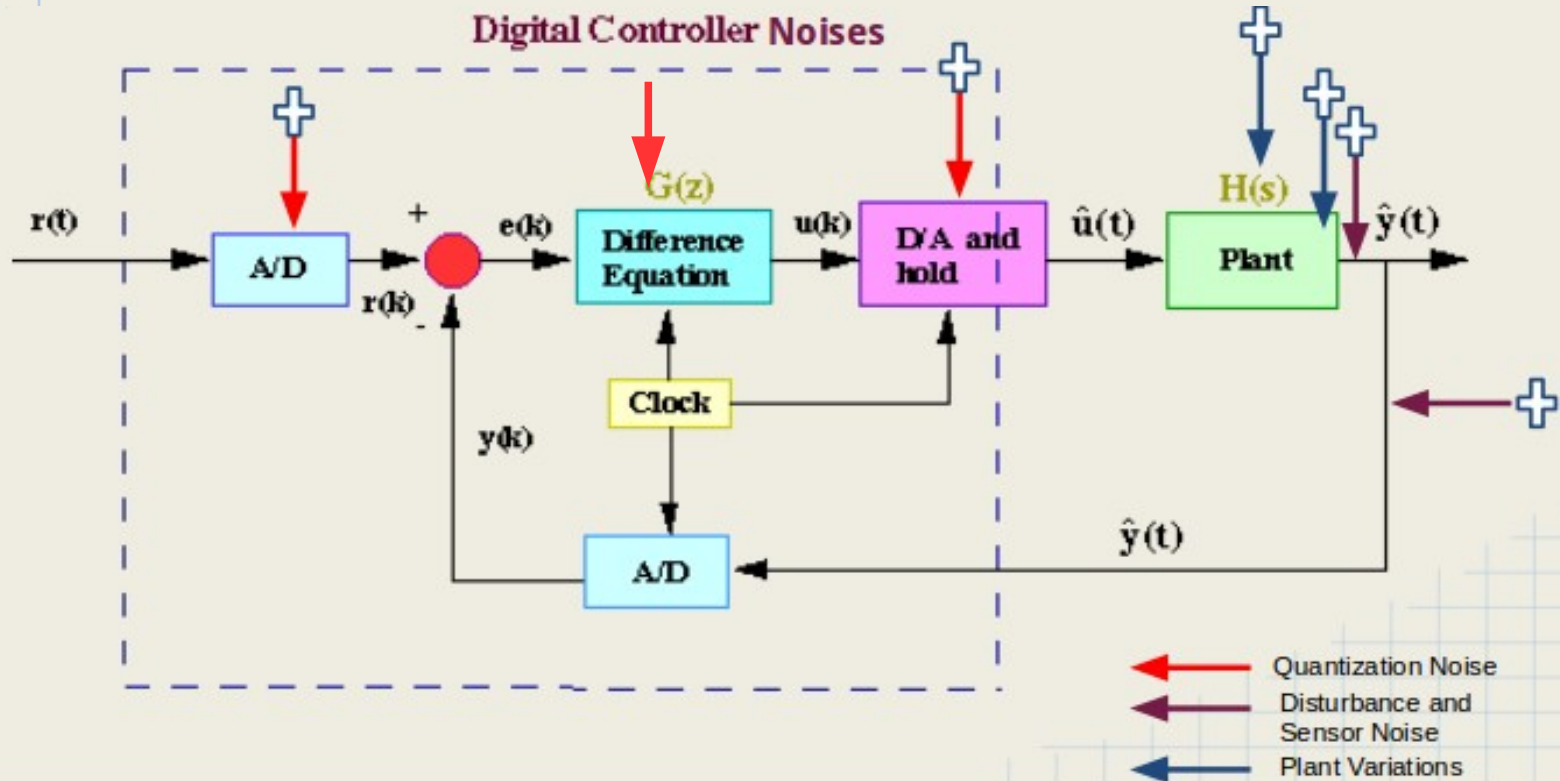

# Improvements Possible

- To improve digital filter performance:
  - Change filter structure
  - Better the precision
  - Error Feedback
- To improve DAC performance:
  - Use higher precision DAC
  - Noise Shaping
- For ADCs:
  - Change Hardware Implementation and Design (Algorithm)

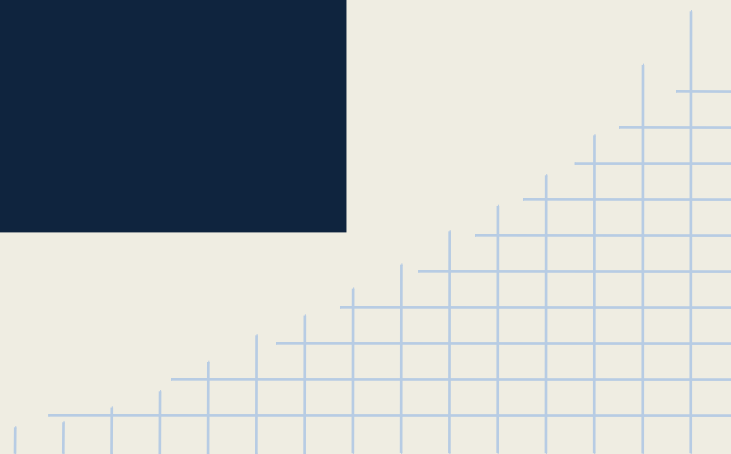
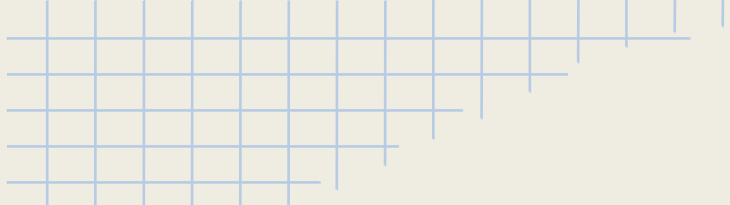

# Quantization Noise Analysis of the Digital Controller

# Background

- Filter Structure (Mathematical Operations, Order)
- State Space Representation of Digital Filters
- Low Noise Form (Matts Evans)
- Time Complexity and Performance
- For double precision implementation: (ref. Denis Martynov)
  - $\text{Output(double)} - \text{Output(single)} = \text{Noise(single)}$
  - $\text{Noise(double)} = \text{Extrapolation factor} * \text{Noise(single)}$



# Improvements in Noise Estimation

- Precise Noise Estimation
- SNR Distribution and Warning System
- Code running time
- SNR Plot

# Automatic Digital Controller Checker Tool

A software tool based on MATLAB which performs the following:

- Searches for valid channel names (For sites, only recorded channels)
- Construct channel names from filter modules in Foton file archive (for all files)
- Download Data -> Perform Noise Estimation -> Plot
- Save the Data for future analysis...and repeat.

# Testing on 40m Controller

- Caltech's 40m prototype Interferometer Digital filters were Analyzed

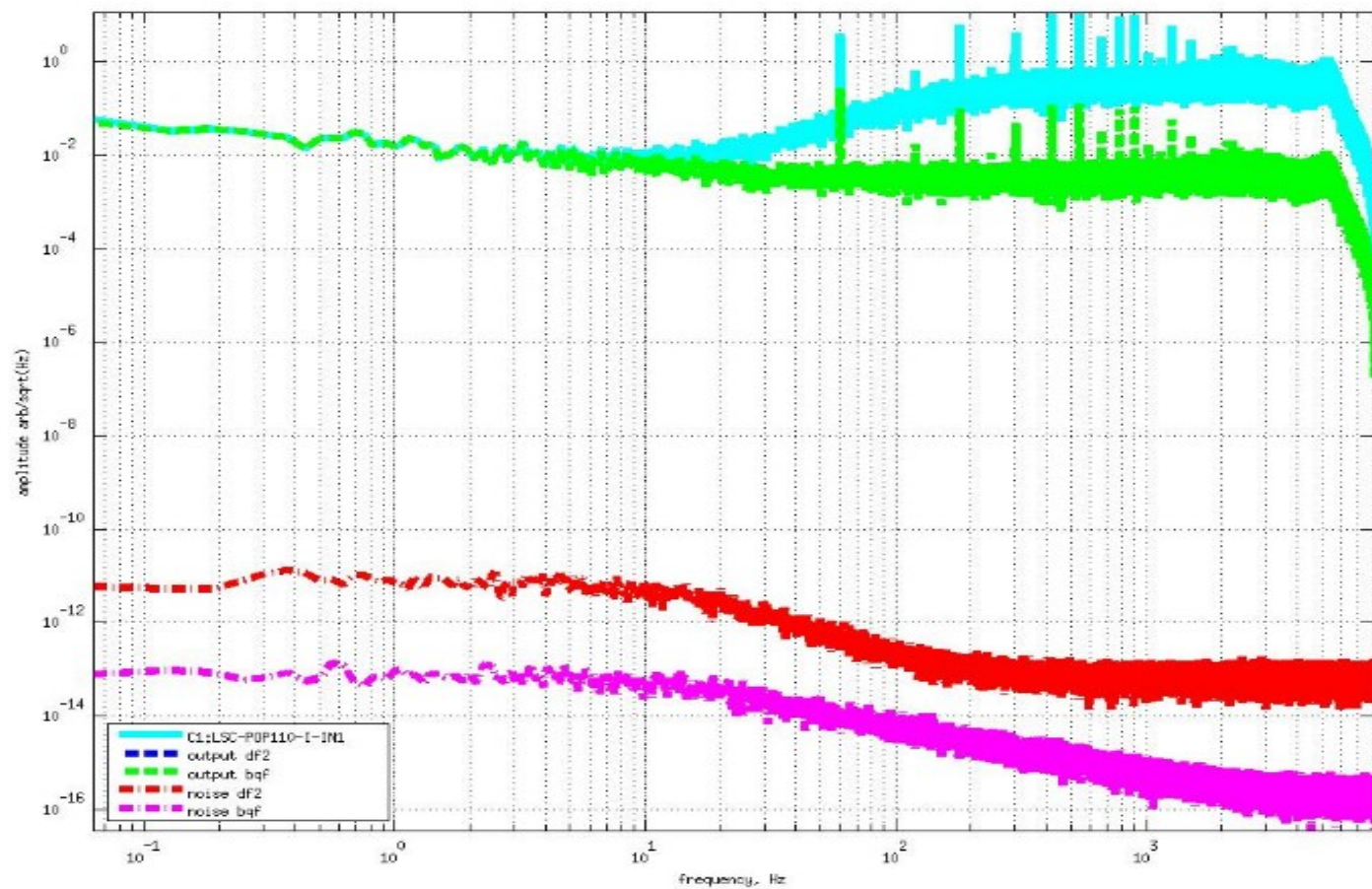

LSC-POP110\_I filter

# For aLIGO sites

- Remote Access to input/output data for digital filters
- Only channels that are recorded
  - Some output channel (only) recorded filters have been checked by inverting the filter
- Foton file archive checked out of SVN at
  - Hanford: GPS Time: 1117896120 : Jun 9 14:41 UTC
  - Livingston: GPS Time: 1117562416: Jun 5 18:00 UTC
- The complete set of resultant plots is available at :

[https://drive.google.com/folderview?](https://drive.google.com/folderview?id=0BzjRW8WwGjzJfkE3cVFzczJVU0JpSkZUTm1DR0dpWF9BWFINVTh3VGg3UG93dHRLTURPZWs&usp=sharing)

[id=0BzjRW8WwGjzJfkE3cVFzczJVU0JpSkZUTm1DR0dpWF9BWFINVTh3VGg3UG93dHRLTURPZWs&usp=sharing](https://drive.google.com/folderview?id=0BzjRW8WwGjzJfkE3cVFzczJVU0JpSkZUTm1DR0dpWF9BWFINVTh3VGg3UG93dHRLTURPZWs&usp=sharing)

# Observations and Inferences

- General Behaviour
  - Digital Filter Noise is way below Output spectrum level.

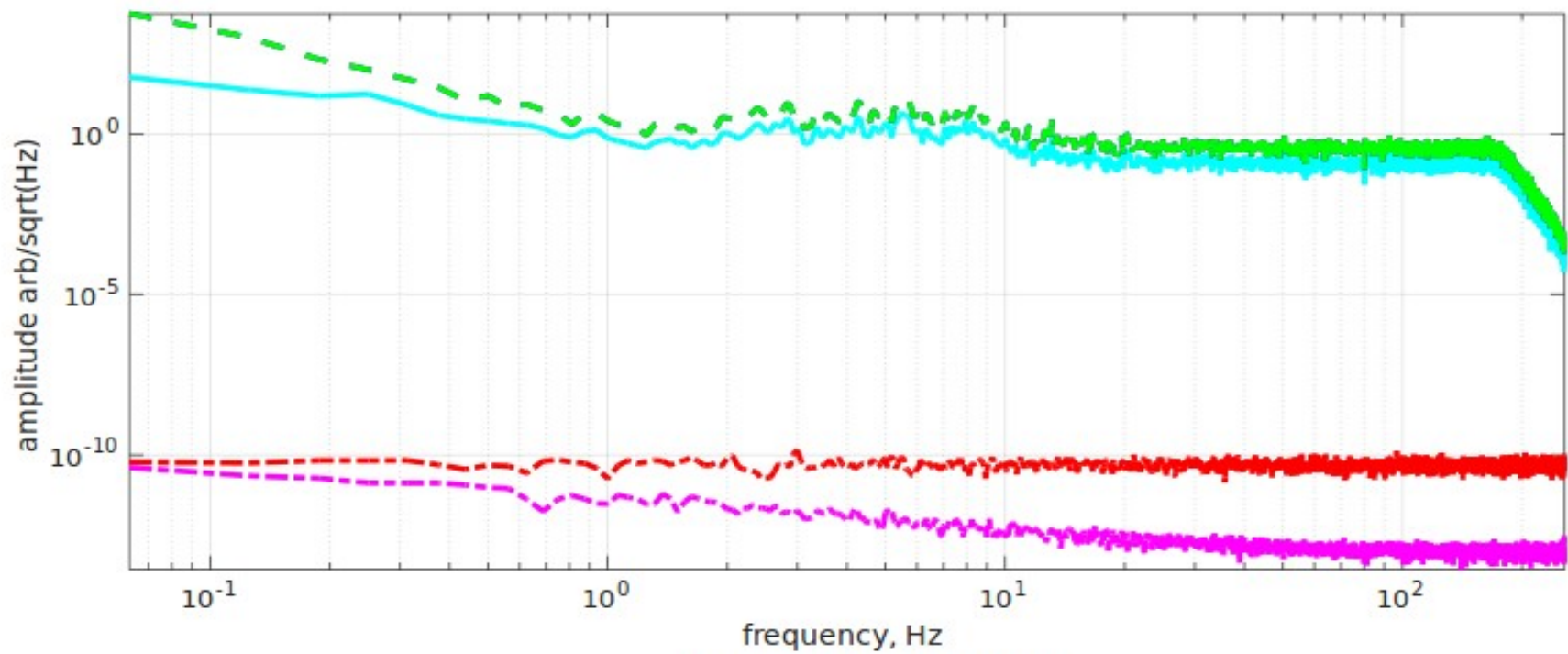

- H1:ISI-ITMY-ST1-CPSINF-H2-IN1-DQ
- - - output df2
- output bqf
- - - noise df2
- - - noise bqf

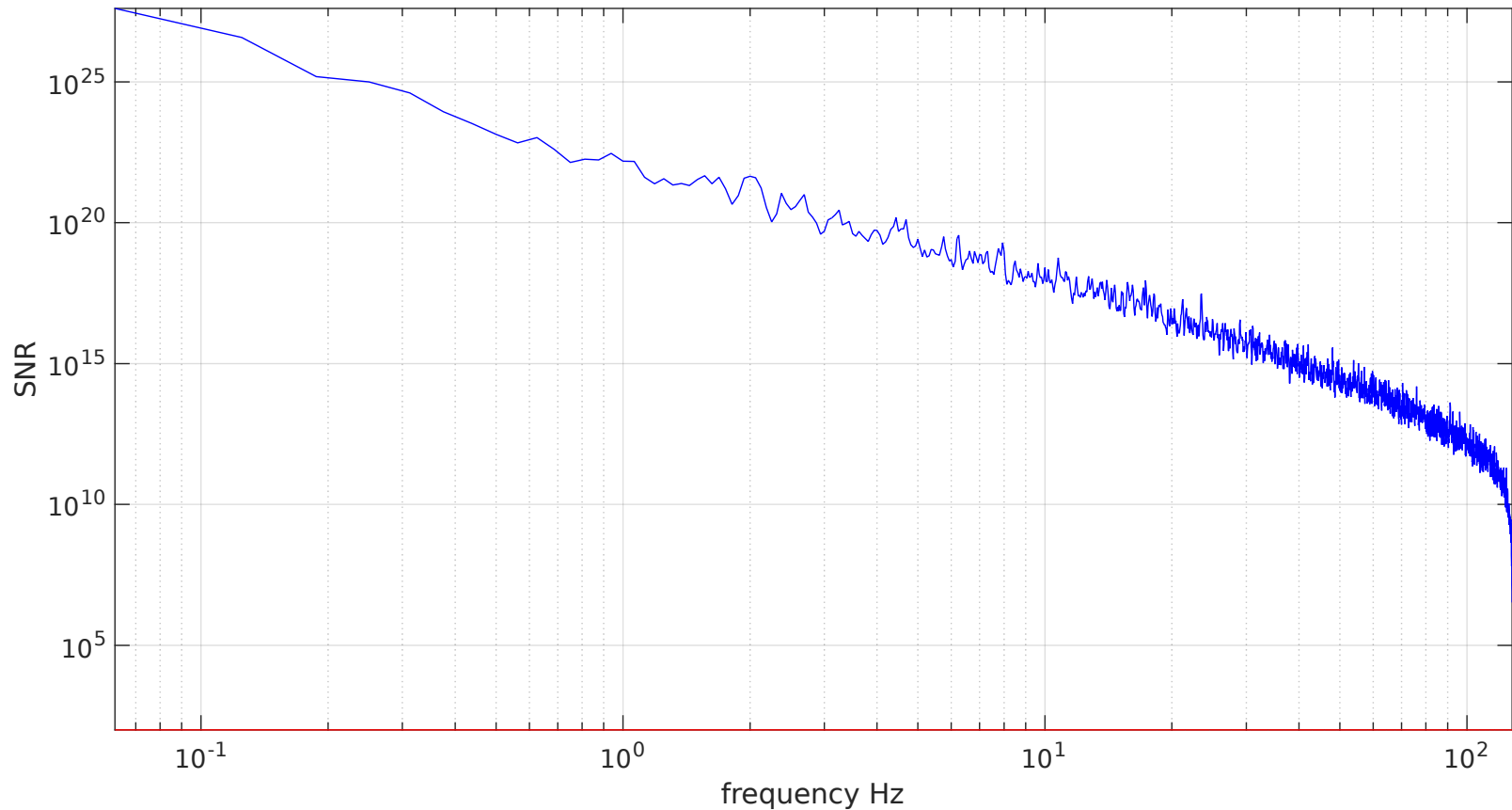

— SNR:H1:SUS-TMSY-M1-DAMP-Y-IN1-DQ



# Filters with High Phase Lag (Higher Order filters)

--SNR level lower

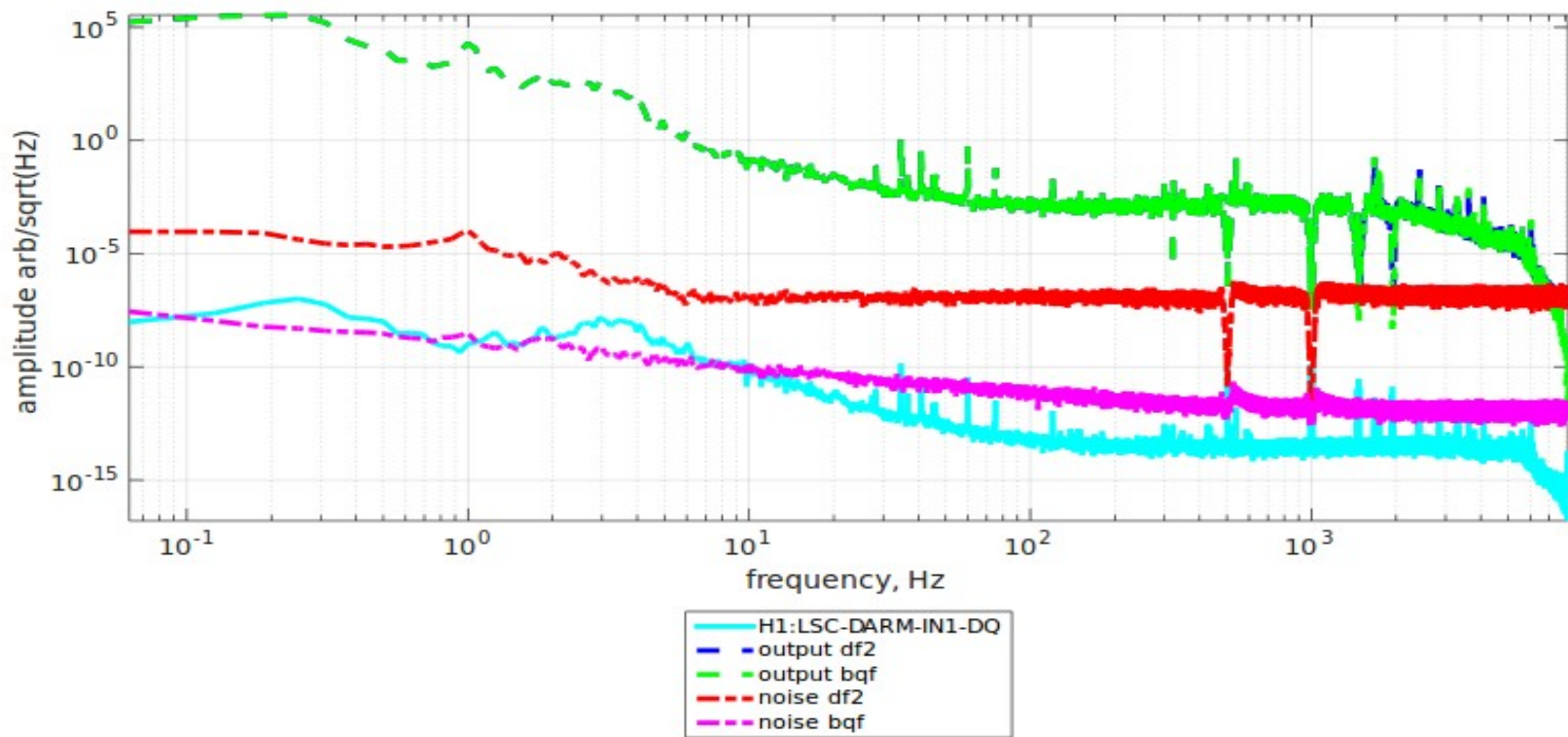

DF2 performs equally well as LNF

--Gain like filters/filters not performing many calculations

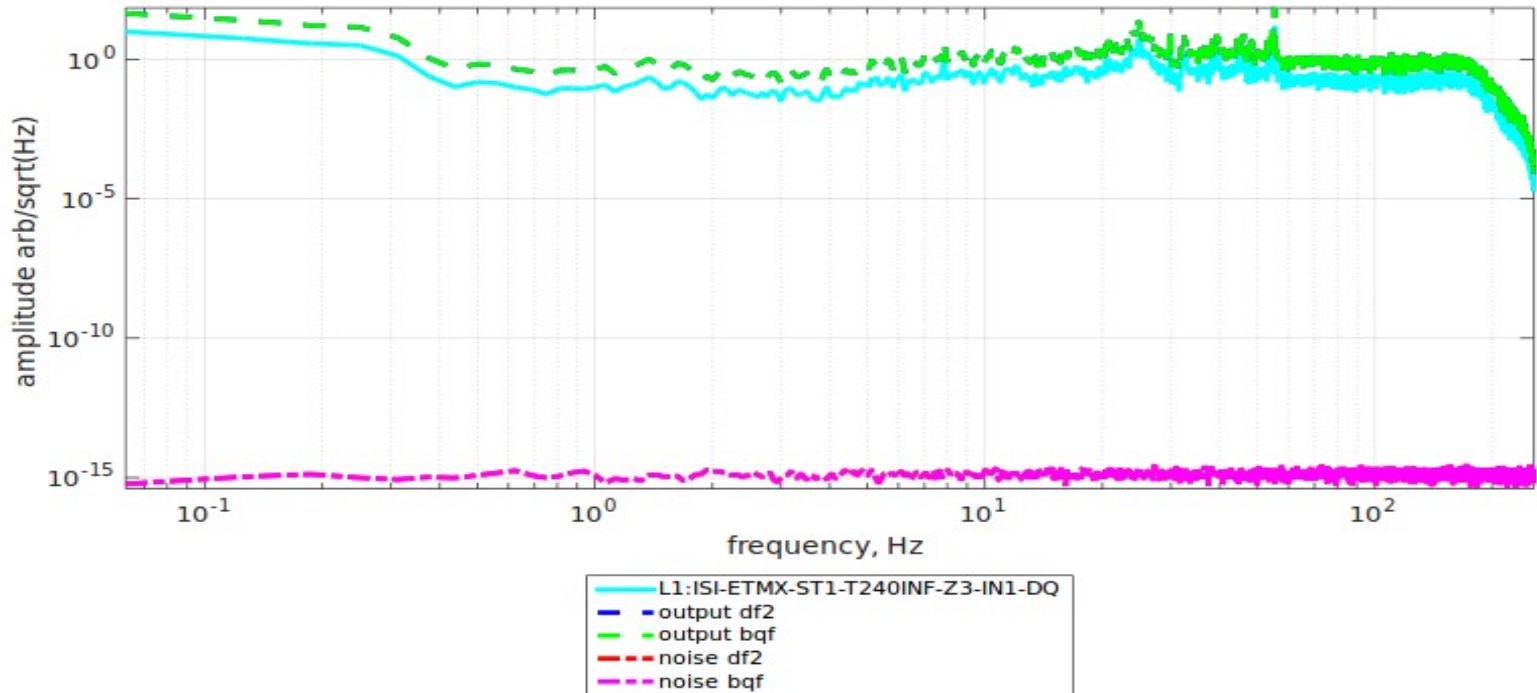

# DF2 above output spectrum

--When Input signal is of very low order + High Phase Lag filter (Combined Effect)

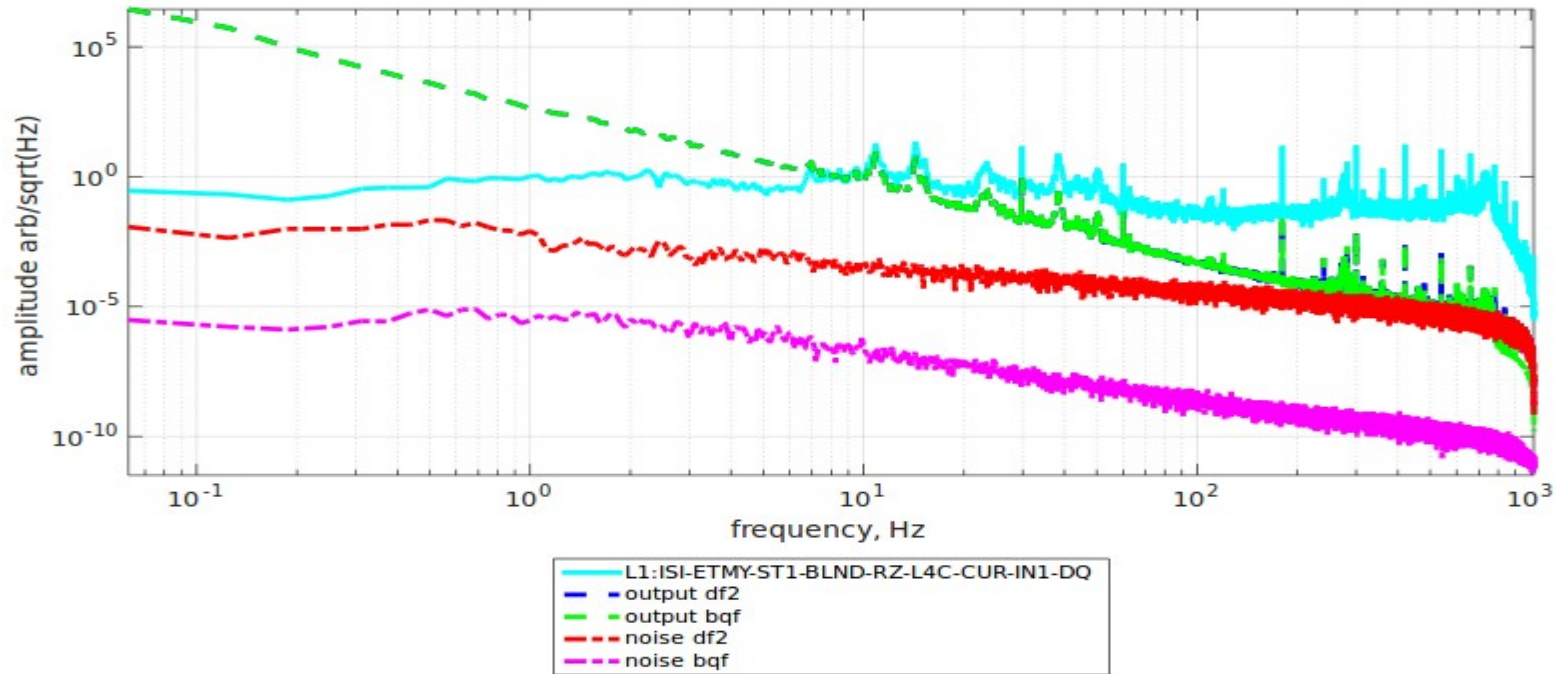

# Other Observations and Inferences

- Dependence and Independence on Input

--Inference: More on the independent side. To an approximation.

- Generally, LNF is better than DF2 by an order of 100

-10,000 SNR

# Filter Inversion

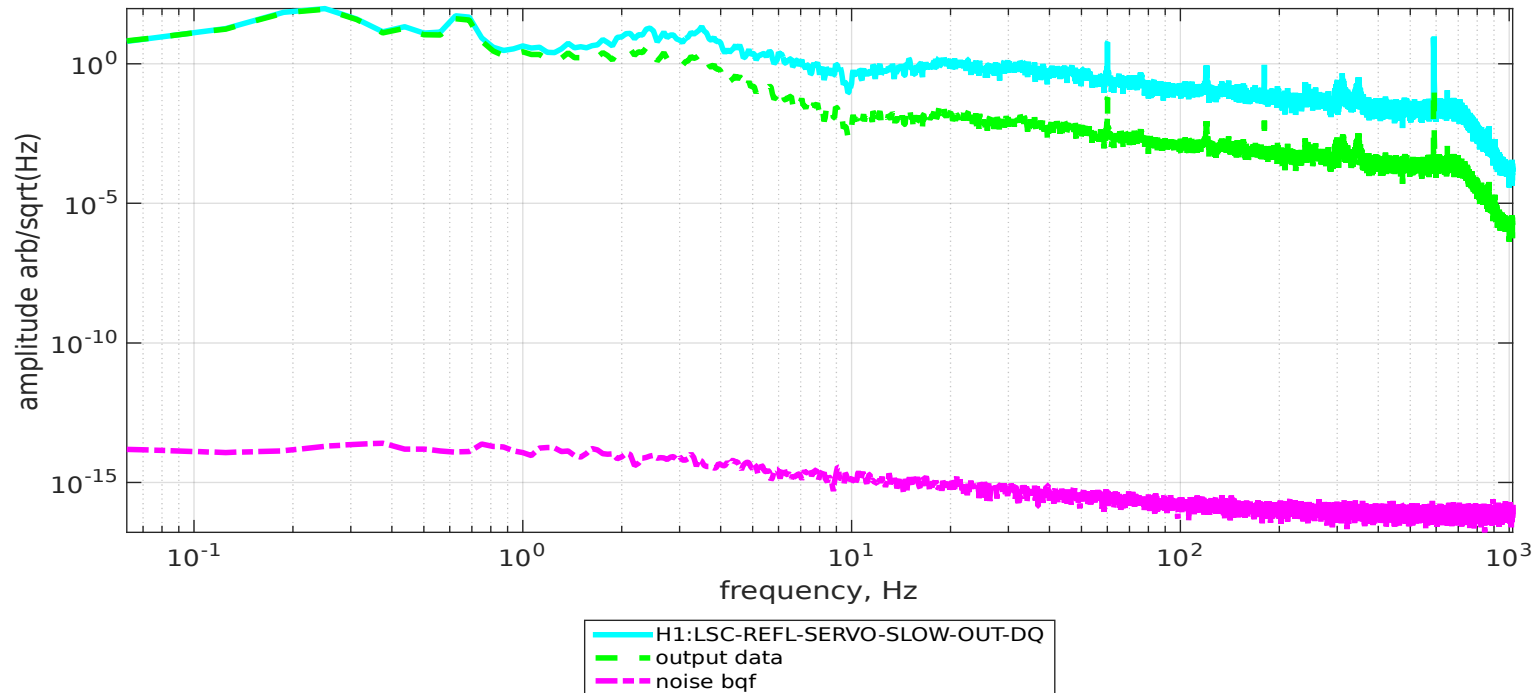

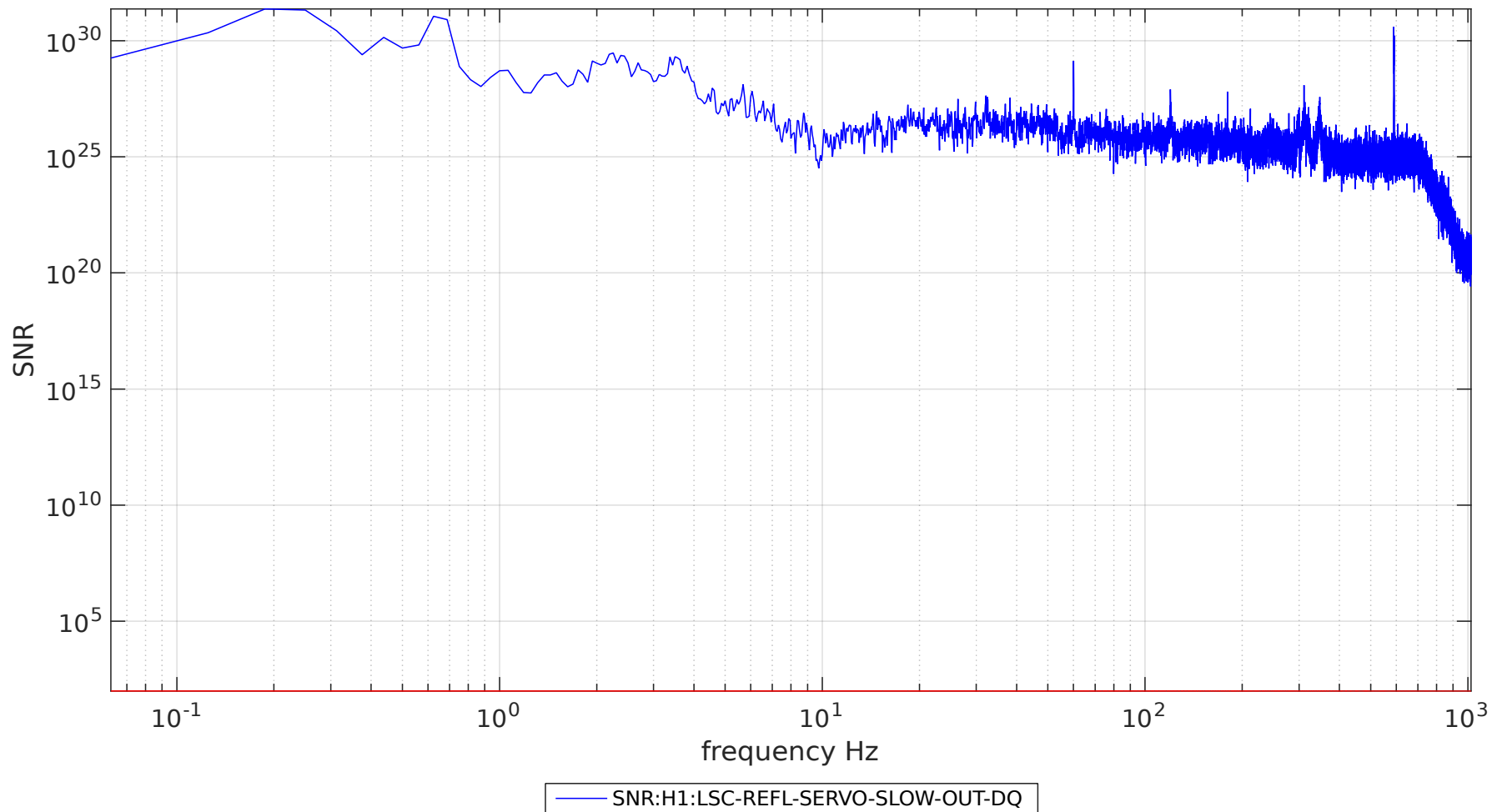

# Limitations and Conclusions

- A major limitation :
  - History of filters: The case when a filter is an integral type or higher order integrals
  - Remedy: Proper Sample time for the filter
- Only recorded channels tested, but there could be problems within the controller
- Major conclusion: LNF filter performs great for most filters (>90%). Even for the other 10%,  $\text{SNR} > 10^2 - 10^3$
- Not all filters can be inverted (from Output to Input) for analysis



# DAC Quantization Noise



# Ways to mitigate DAC Noise

- Using higher precision DACs
  - But, there are hardware limitations
  - Also, processing speed
- DAC architecture improvements
- DAC Noise Shaping
  - Low noise in a particular band of frequencies at the cost of higher overall noise level.

# DAC Noise Measurement

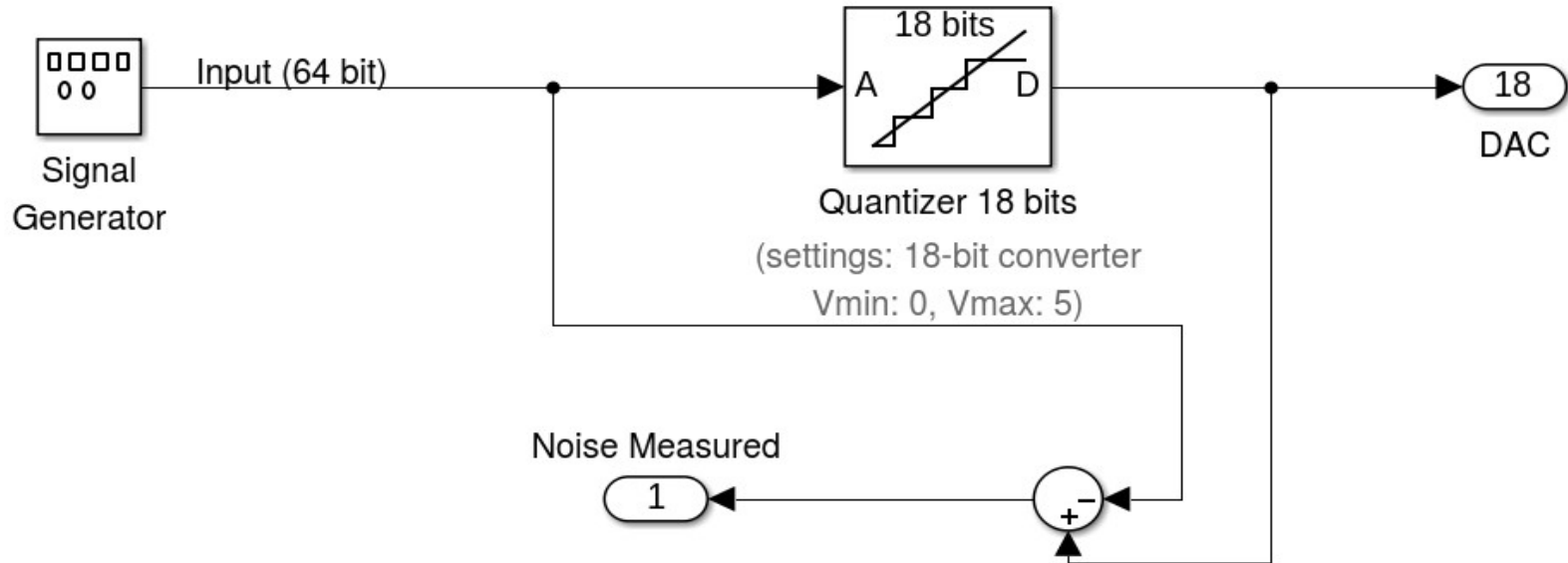

# DAC Noise Shaping

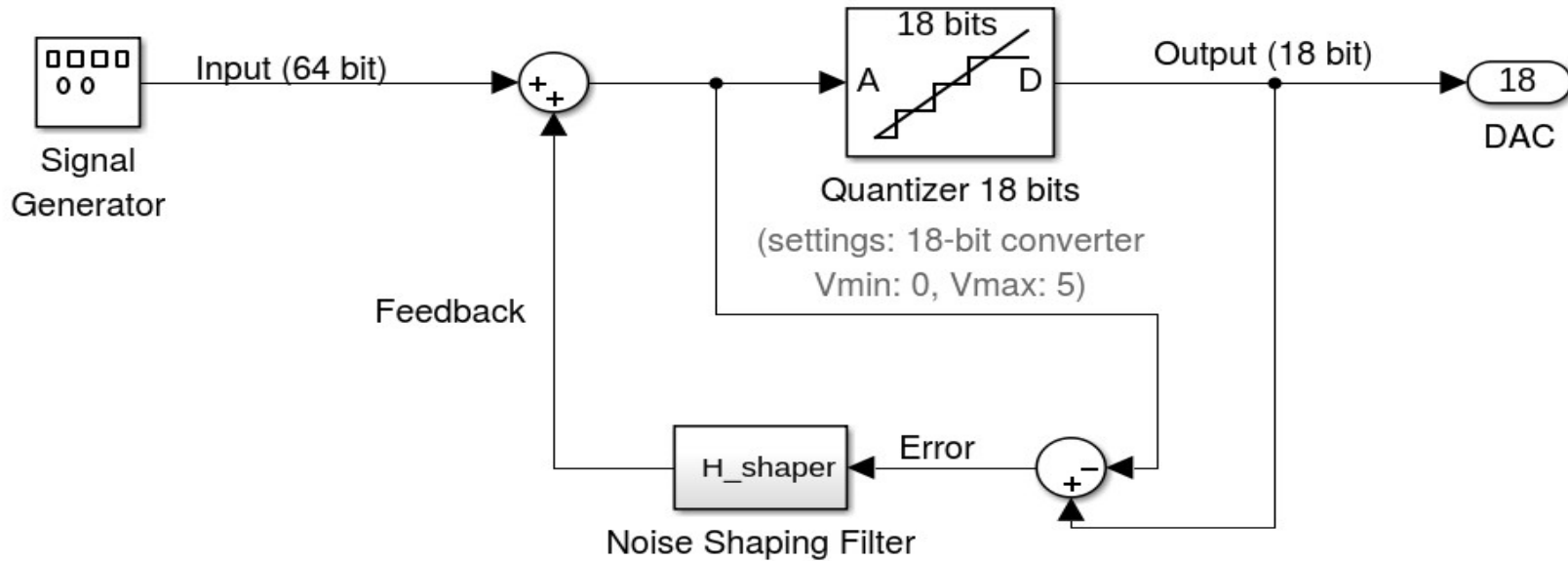

# Background : Noise Shaping

- On simple block diagram analysis,

$$X'(z) = X(z) + E(z) (-1 + H\_shaper(z))$$

where,  $X'(z)$  is output transfer function in z-domain and similarly,  $X(z)$  is input,  $E(z)$  is quantization error and  $H\_shaper(z)$  is feedback transfer function

- Since, the noise needs to be fed back after a delay, the above equation is modified to be like:

$$X'(z) = X(z) + E(z) (-1 + z^{-1}H\_target(z))$$

where the delay is accounted for in the code.

- Essentially, noise is now “shaped” or modified according to our own choice.

# Customized Noise Shaping for aLIGO DAC

- The robustness of the noise shaping algorithm.
- Suppress any peak (notch) in Quantization noise
- Or, suppress a particular band of frequencies all together.

With a compensation elsewhere.

### noise shaping

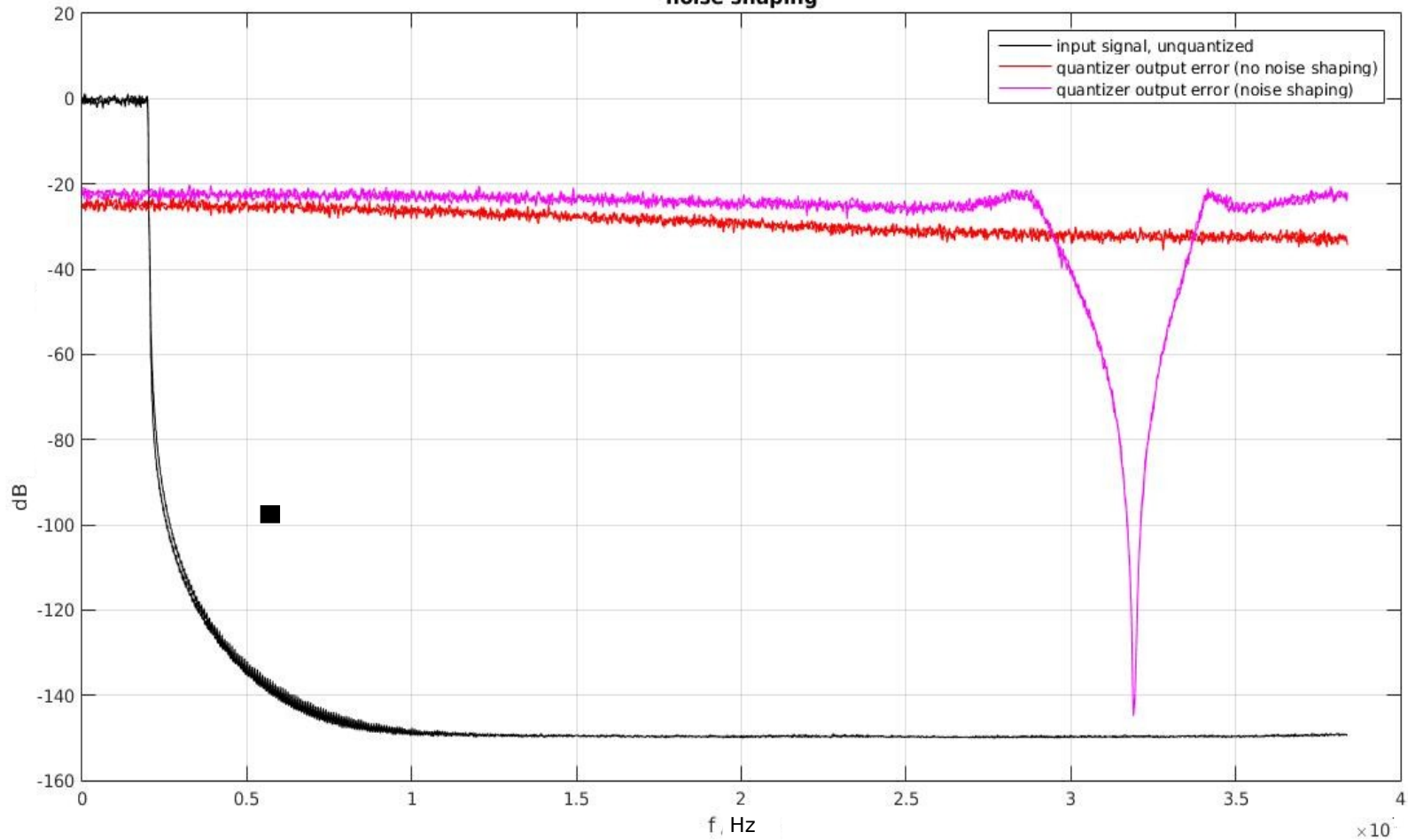

# Simulations in MATLAB

- Algorithm implemented in MATLAB gave successful results for any arbitrary noise shape.
- For a high pass shaped noise (which is desirable for GW detection):

Plot : Next Slide

### noise shaping

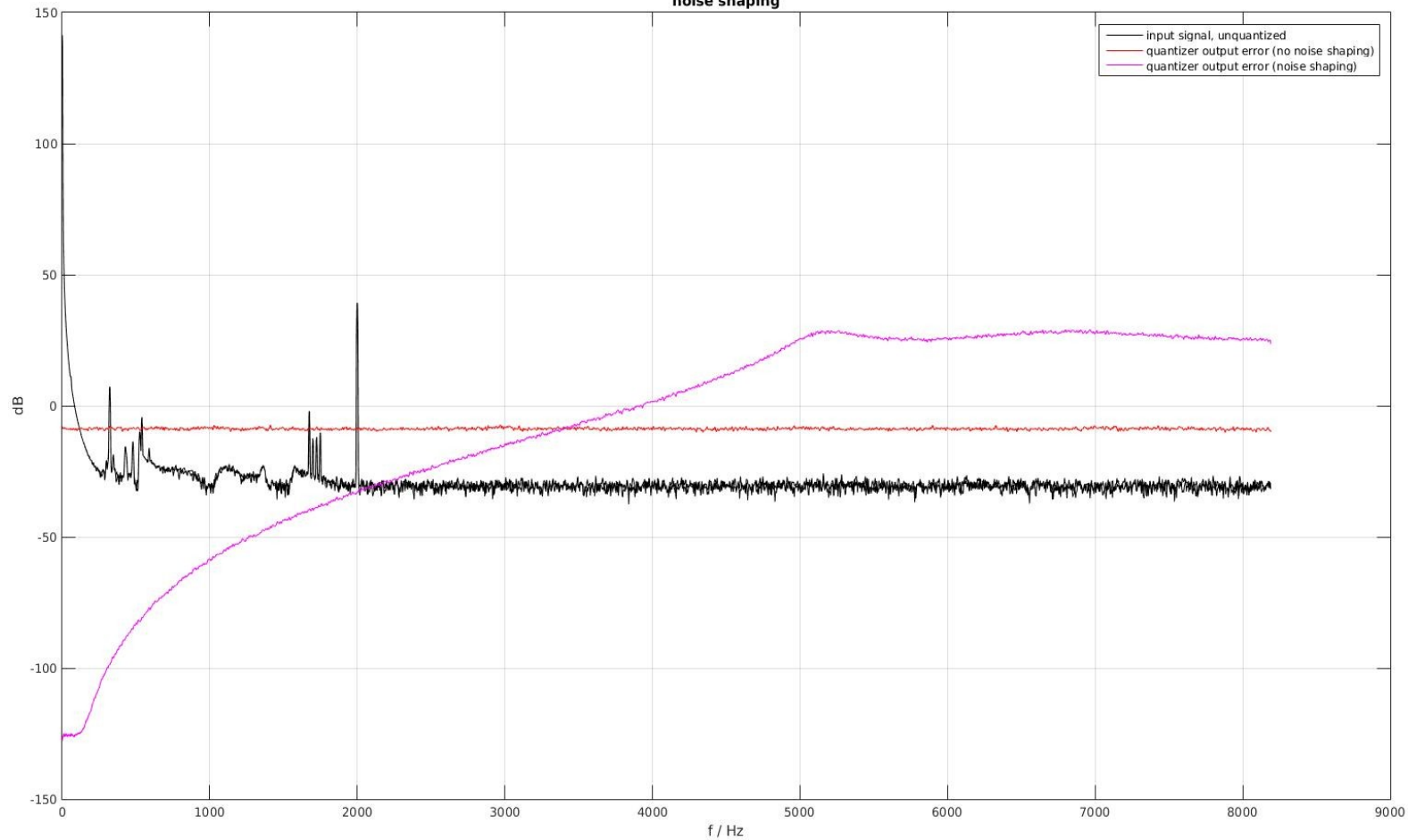



# Implementation in C

To enable the frontend code to take advantage of the noise shaping algorithm developed.

- Filtering done using SOS coefficients
- No plotting in this case, hence error debugging with respect to MATLAB simulation results
- Noise shaped data given to the DAC

# Project Conclusions and Scope

- ❖ There are two major conclusions of the project work and the research done in this project:
  - For most of the filters analyzed, the low noise form performed better than DF2 and also SNR for most of them was acceptable.
  - That being said, an exclusive testing of the controller still remains to be done as signals inside the controller were not tested.

# Project Conclusions and Scope

## DAC Quantization Noise

A primary concern due to its higher level has been mitigated to a great extent, according to the noise shaping algorithm proposed.

The future scope would be to completely implement it in the system and take advantage of it.



Q & A

Thank You!

