

The LIGO detection and opportunities for NASA in Gravitational Wave Astronomy

LIGO Hanford Observatory: GW150914

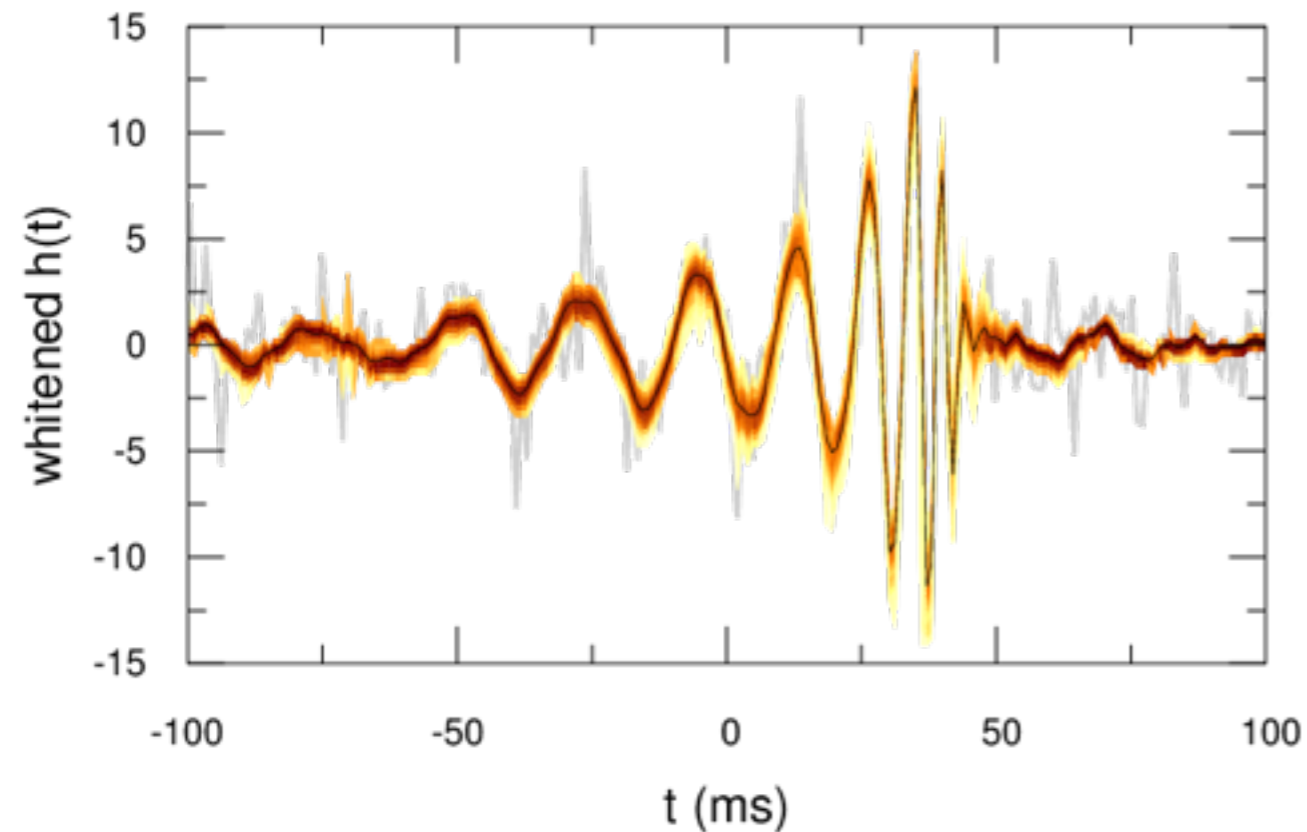

LIGO Livingston Observatory: GW150914

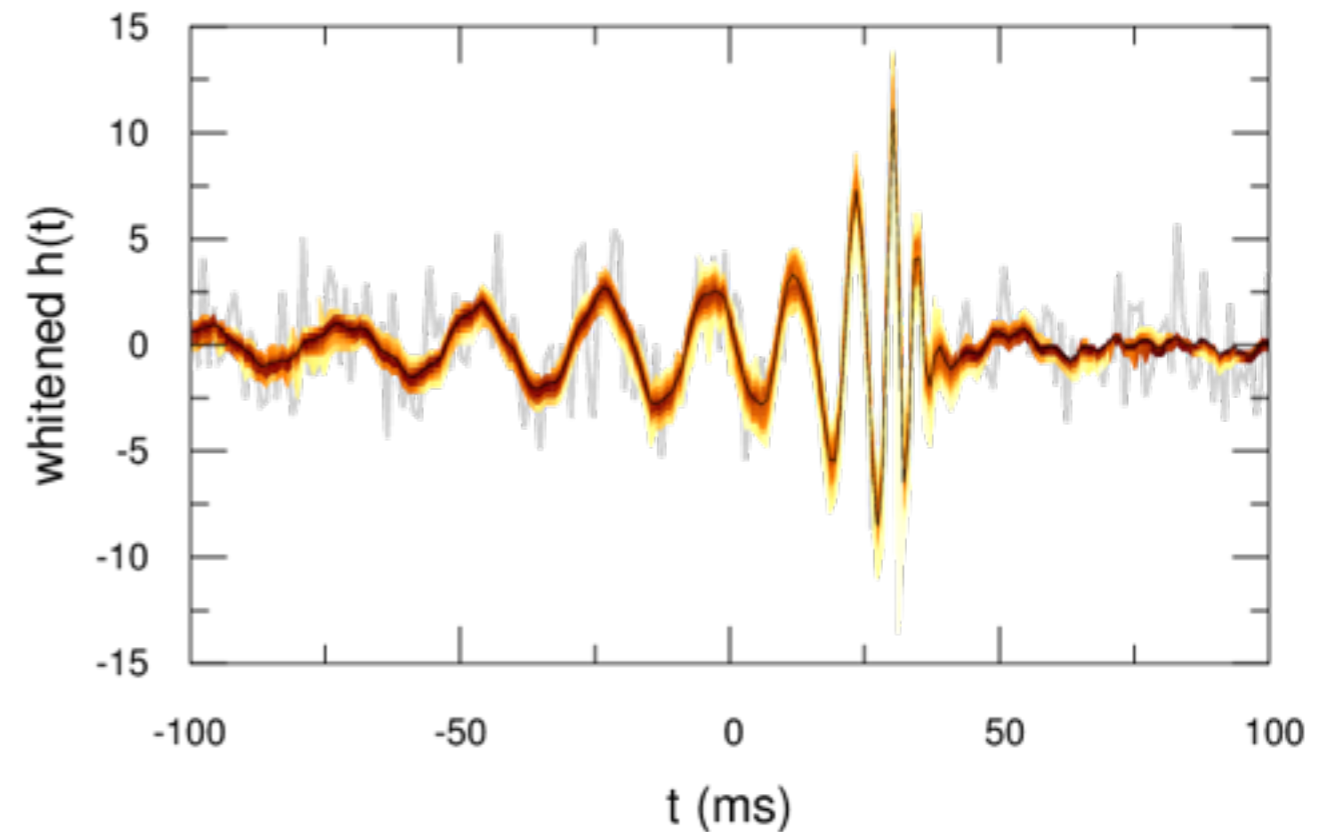

GW150914: A story 40+ years in the making

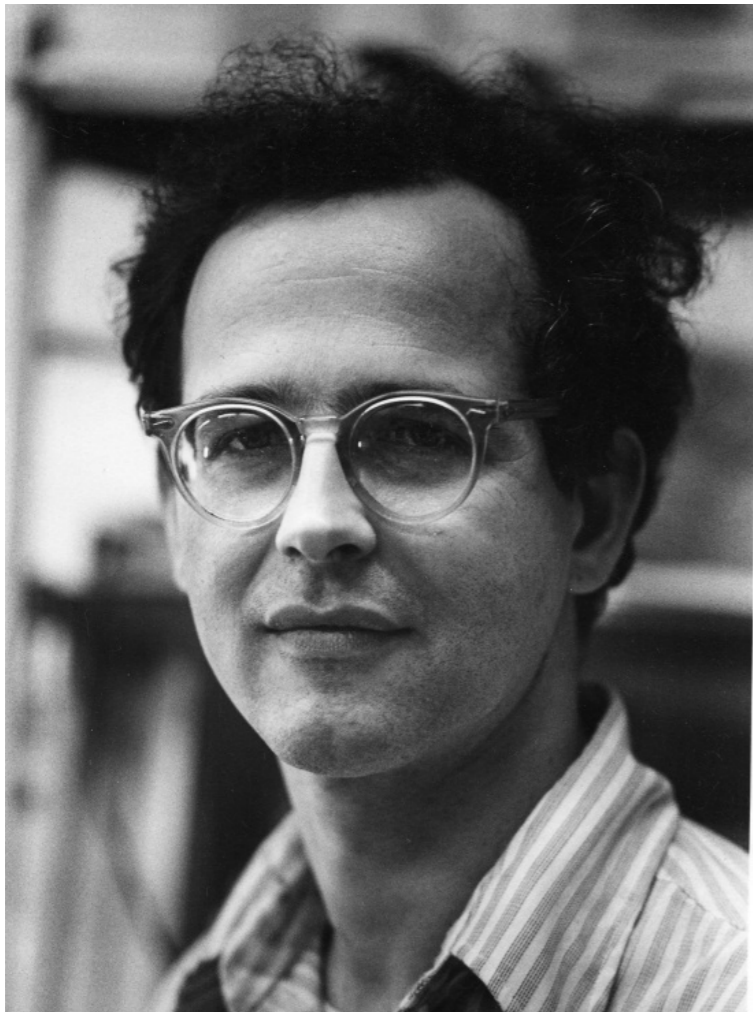

Rai Weiss



Kip Thorne



Ron Drever

GW150914: A story 40+ years in the making

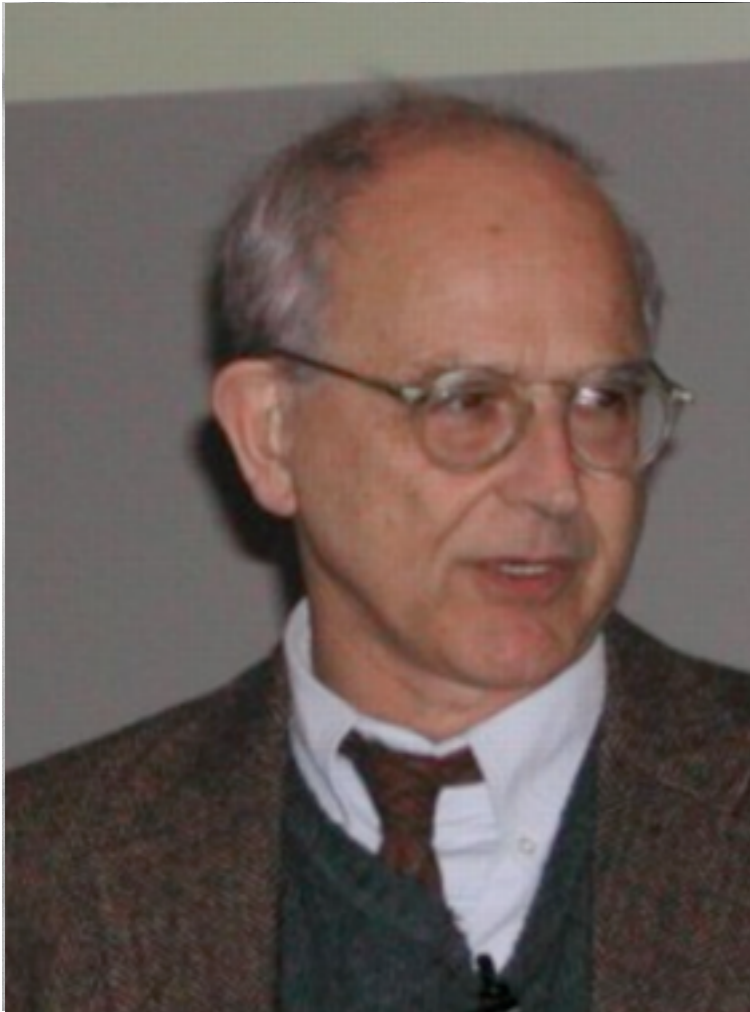

Rai Weiss



Kip Thorne



Ron Drever

LIGO's Sensitivity Progression

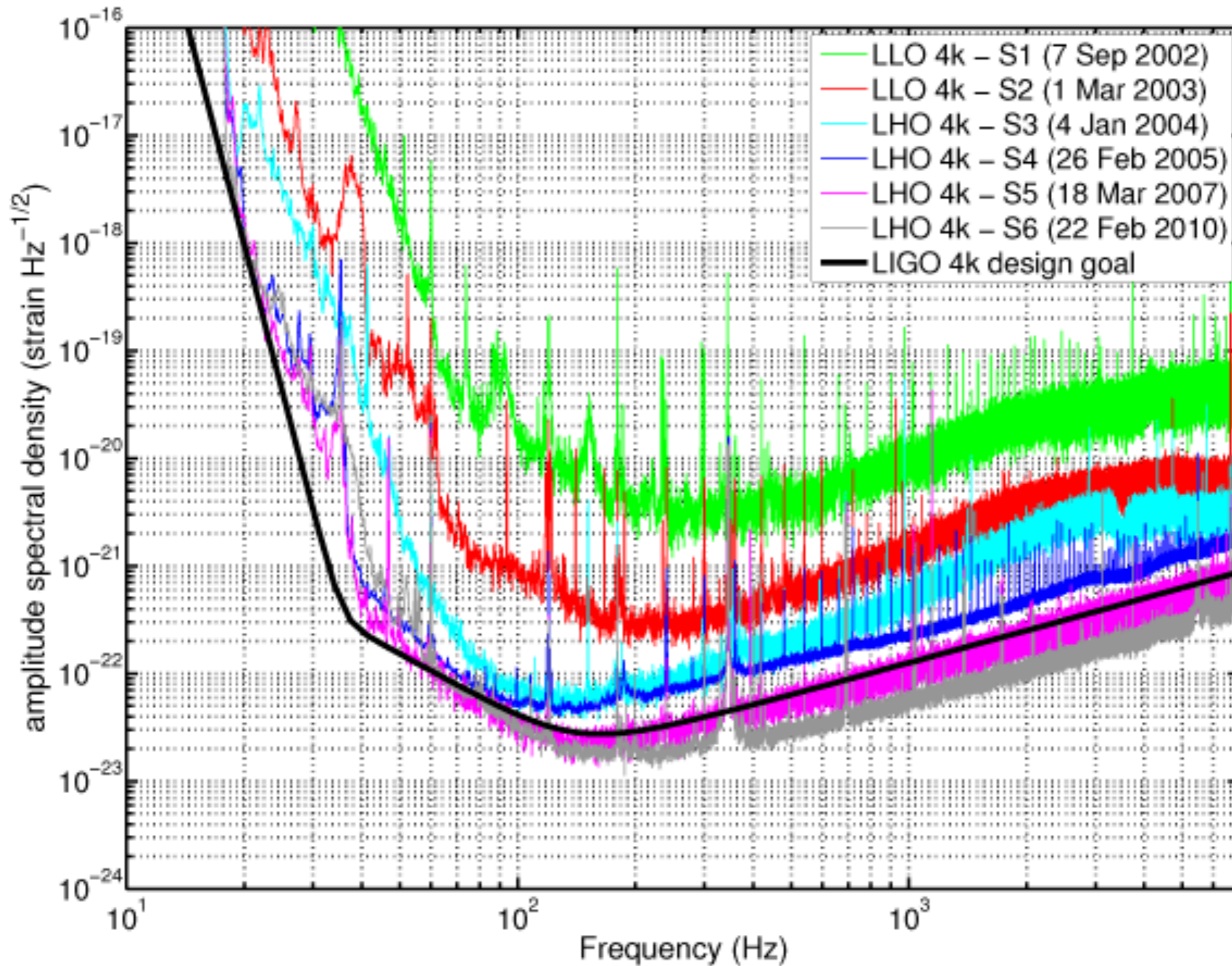

LIGO's Sensitivity Progression

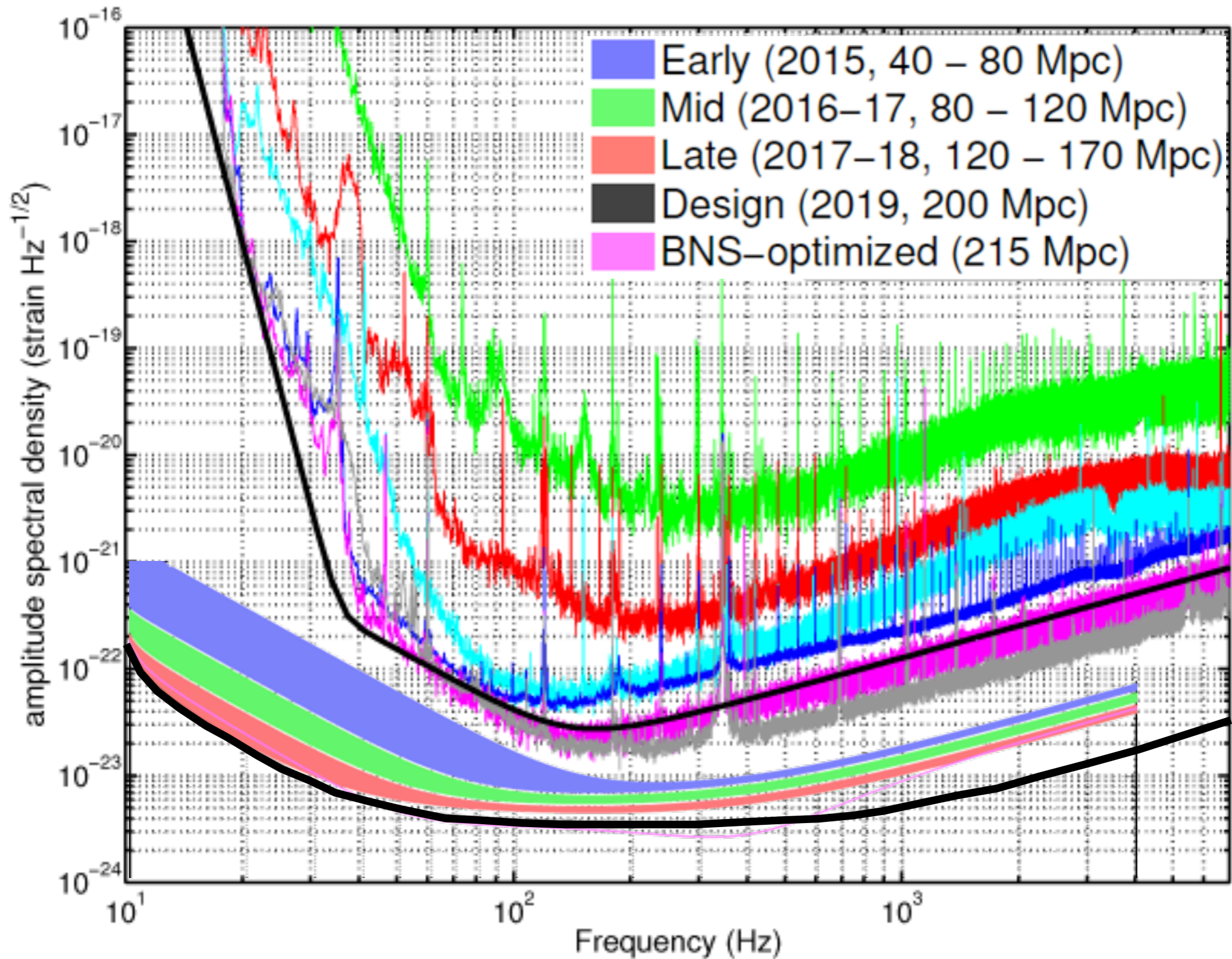

aLIGO's First Observing Run

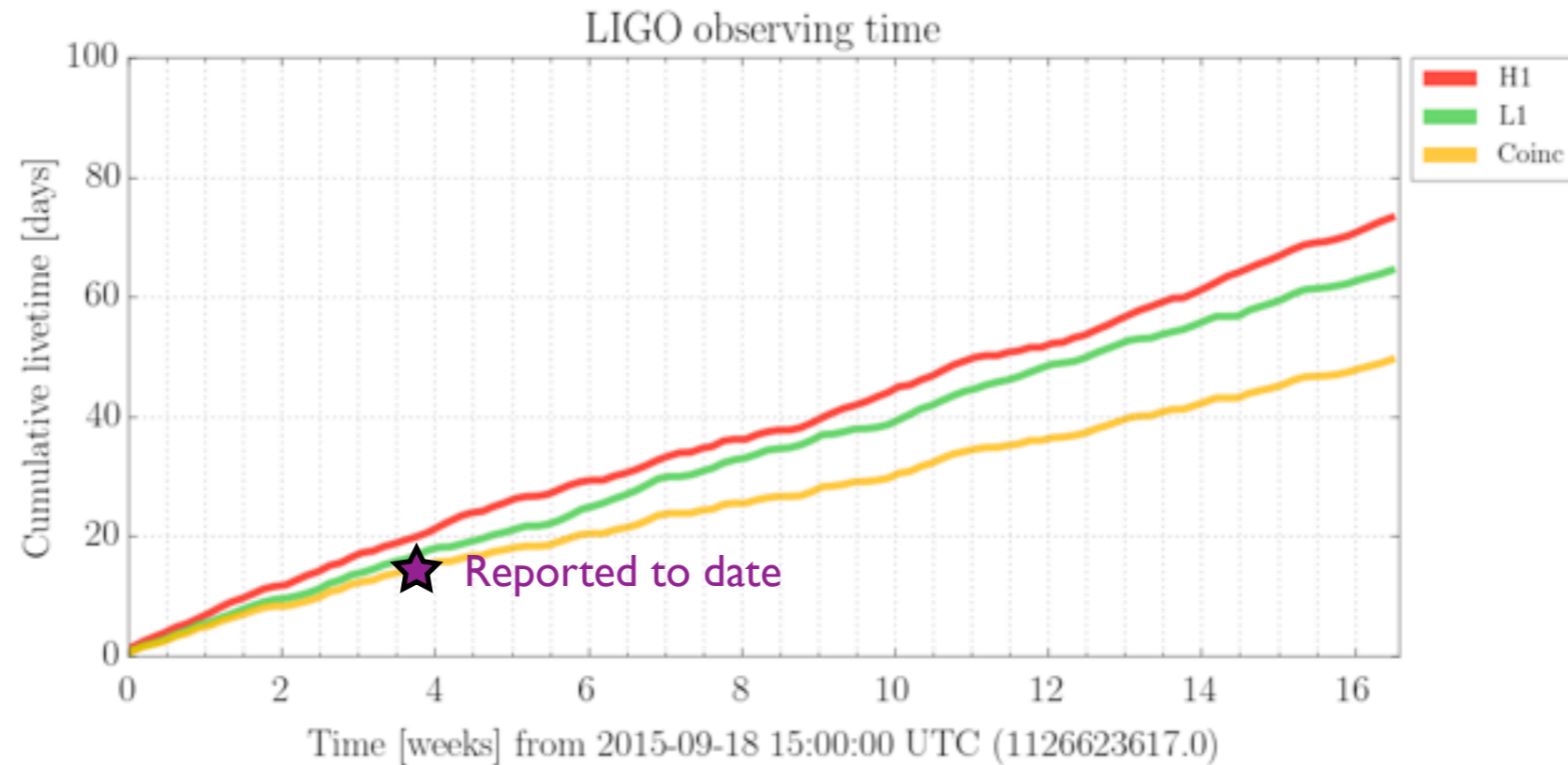
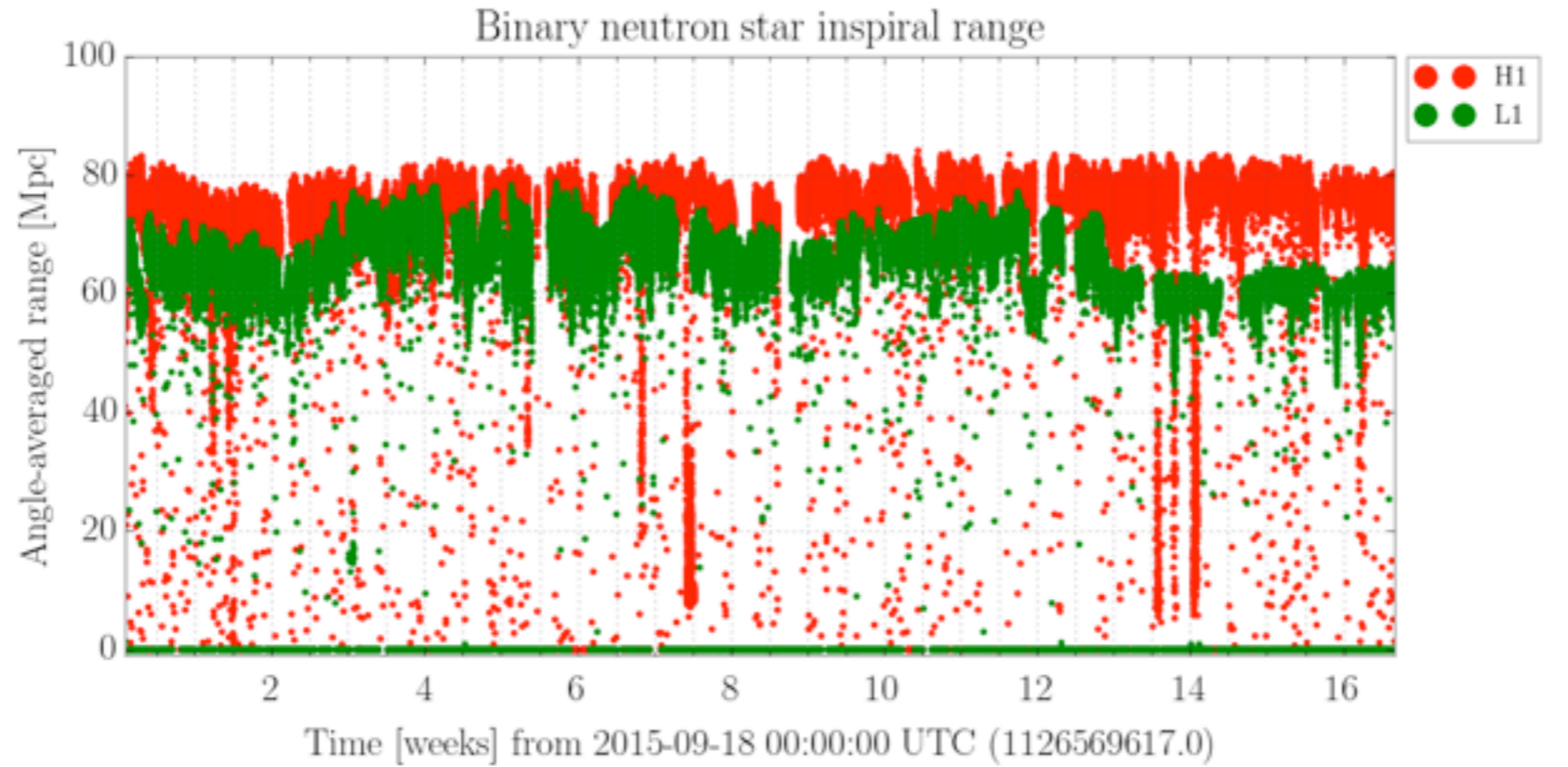

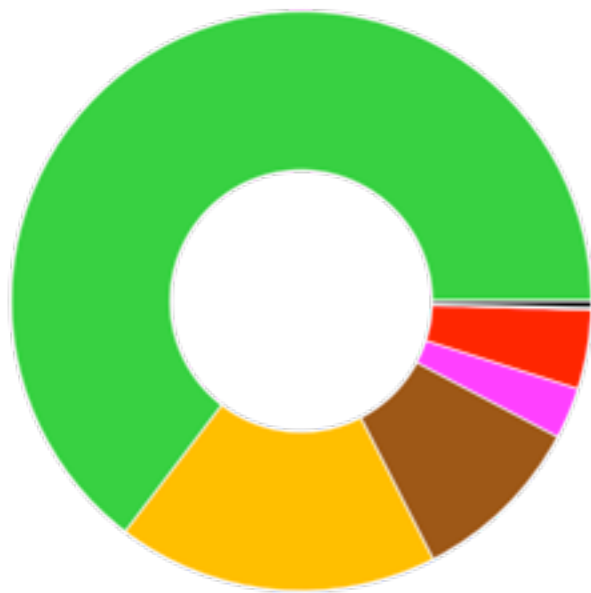

H1 operating mode overview

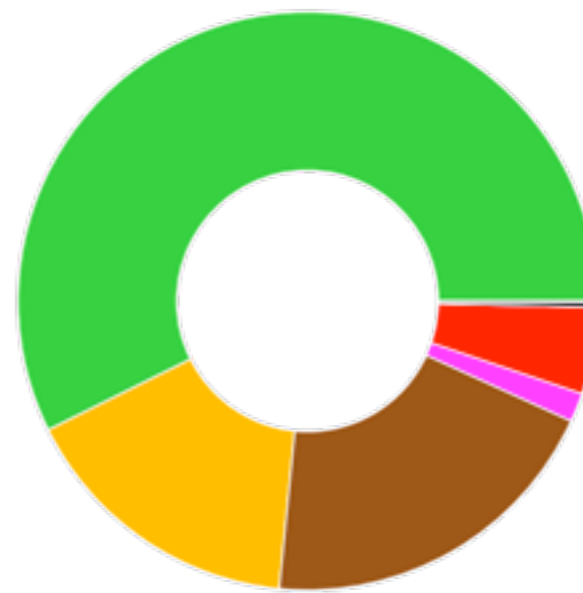
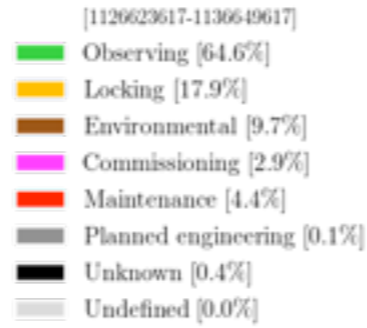

L1 operating mode overview

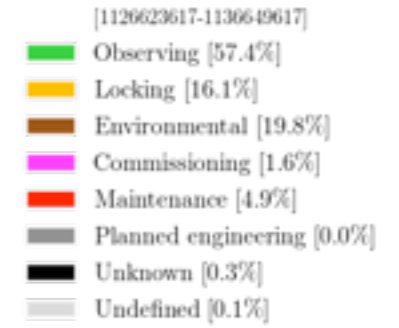

~41% Coincident Duty Cycle

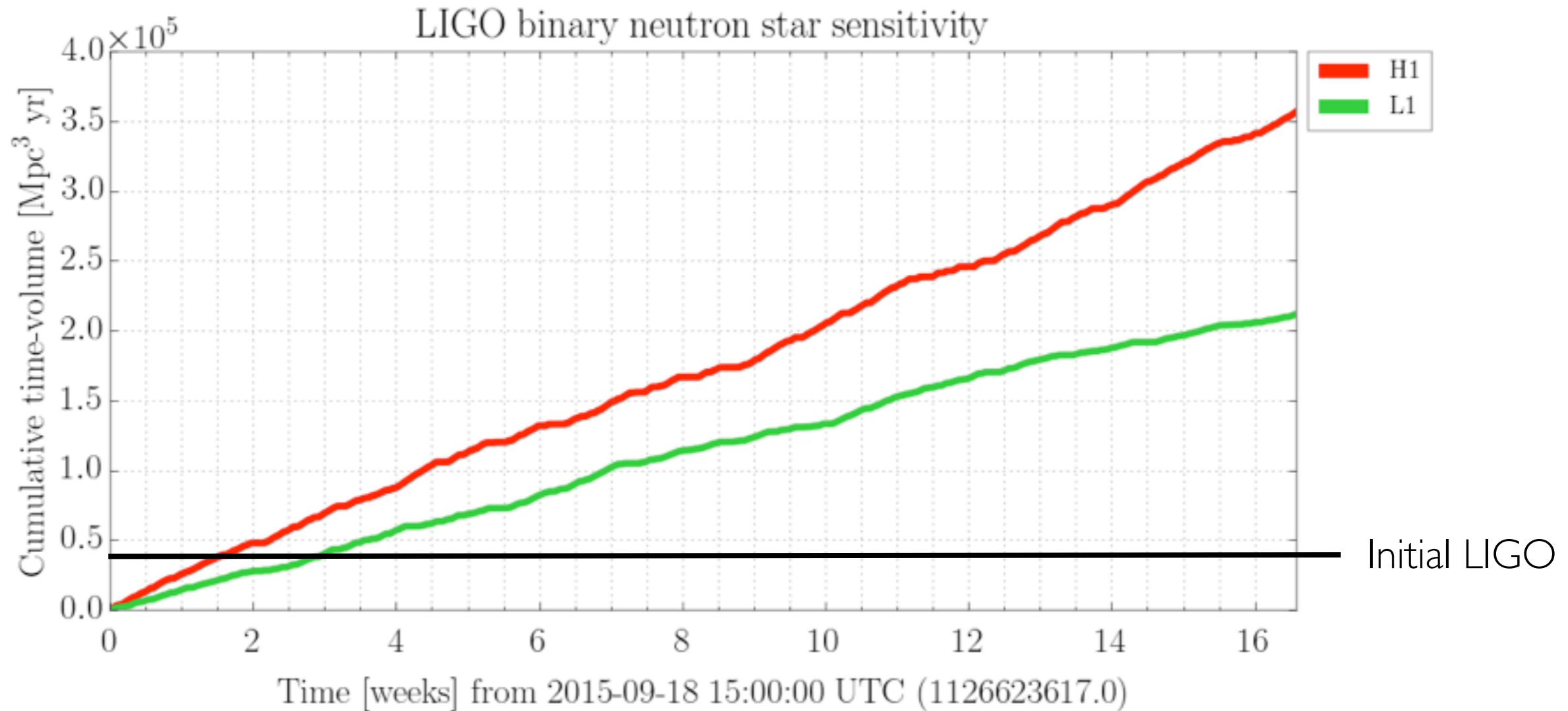

Early Morning, September 14 2015

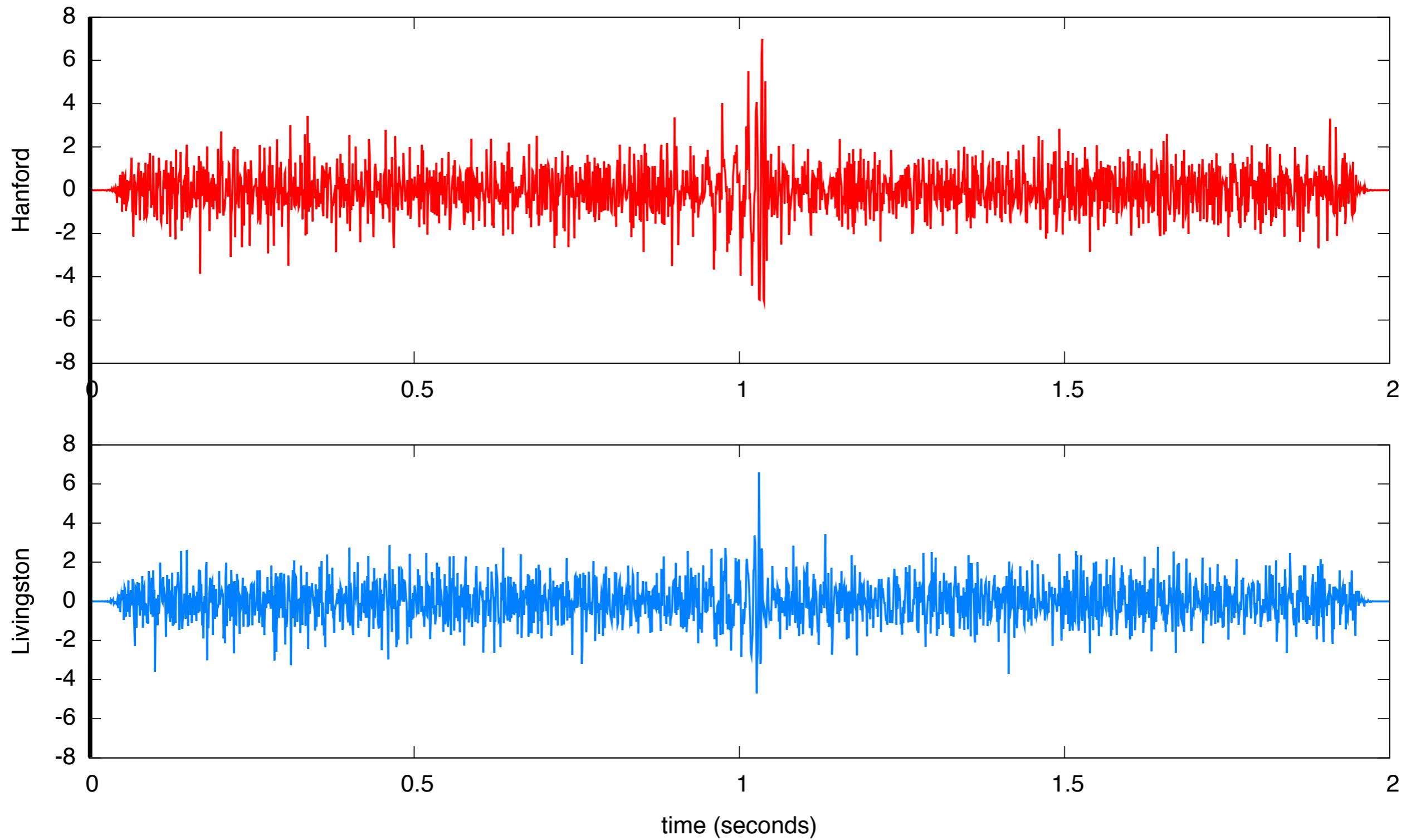

Early Morning, September 14 2015

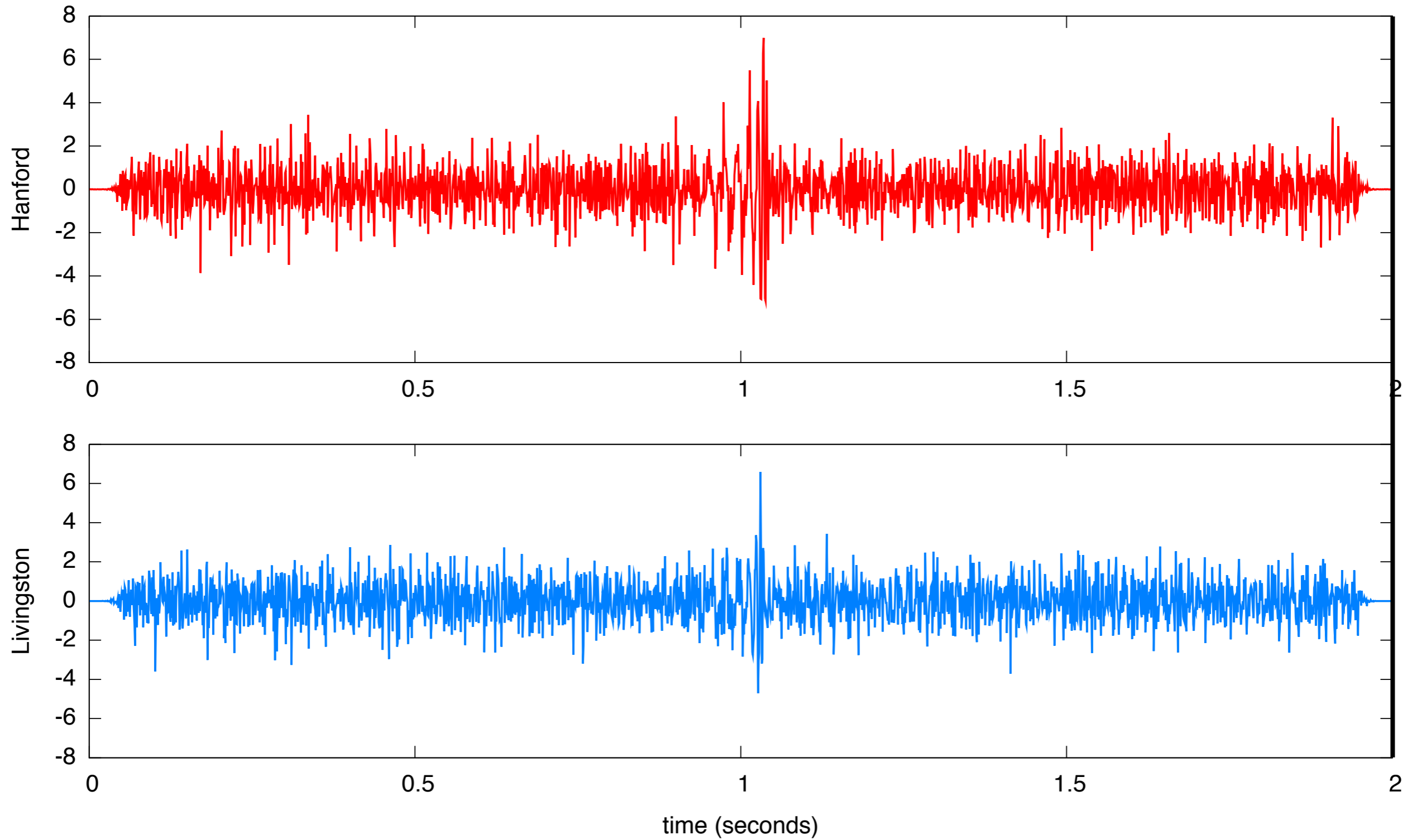

Wavelet Reconstruction of coincident signal

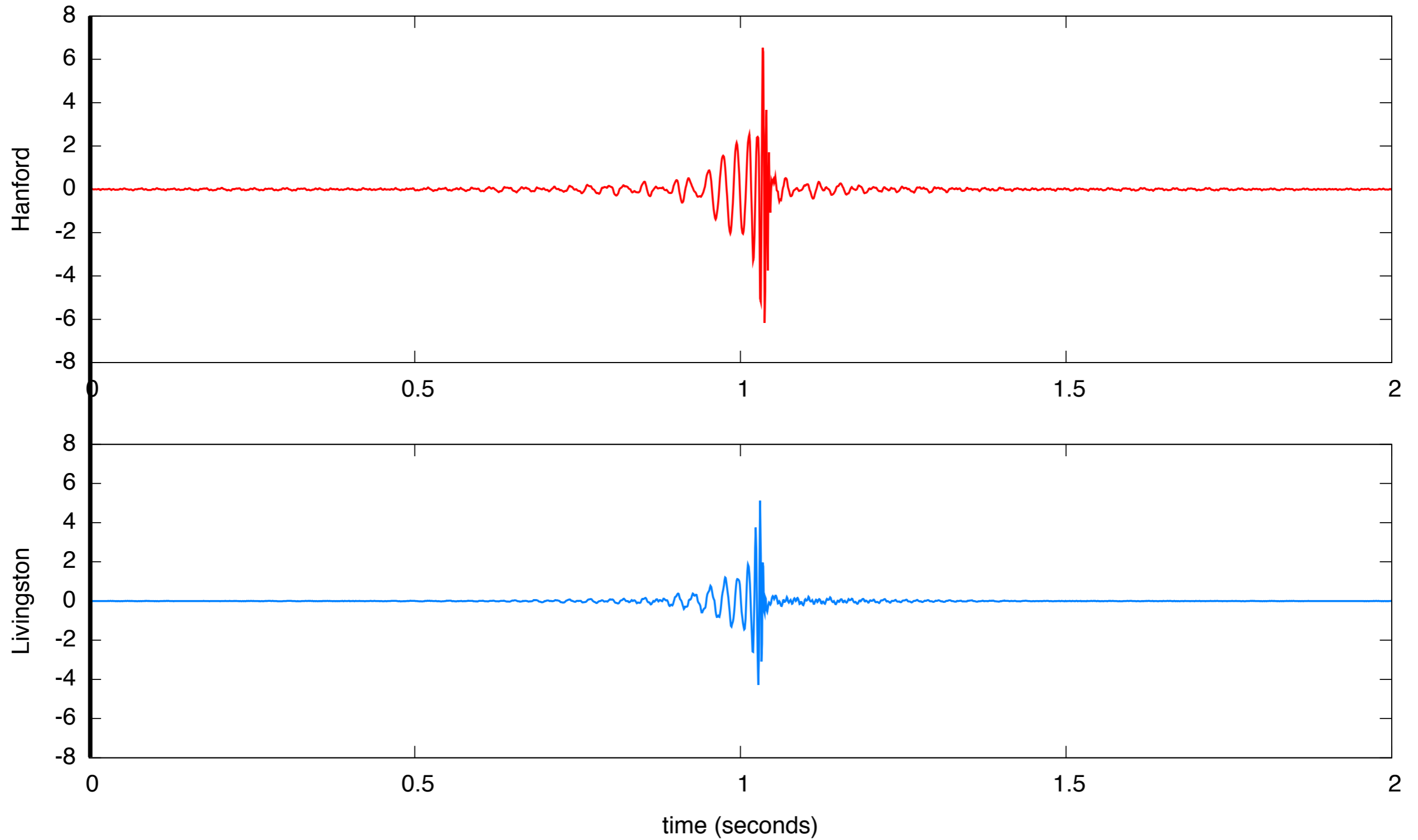

Wavelet Reconstruction of coincident signal

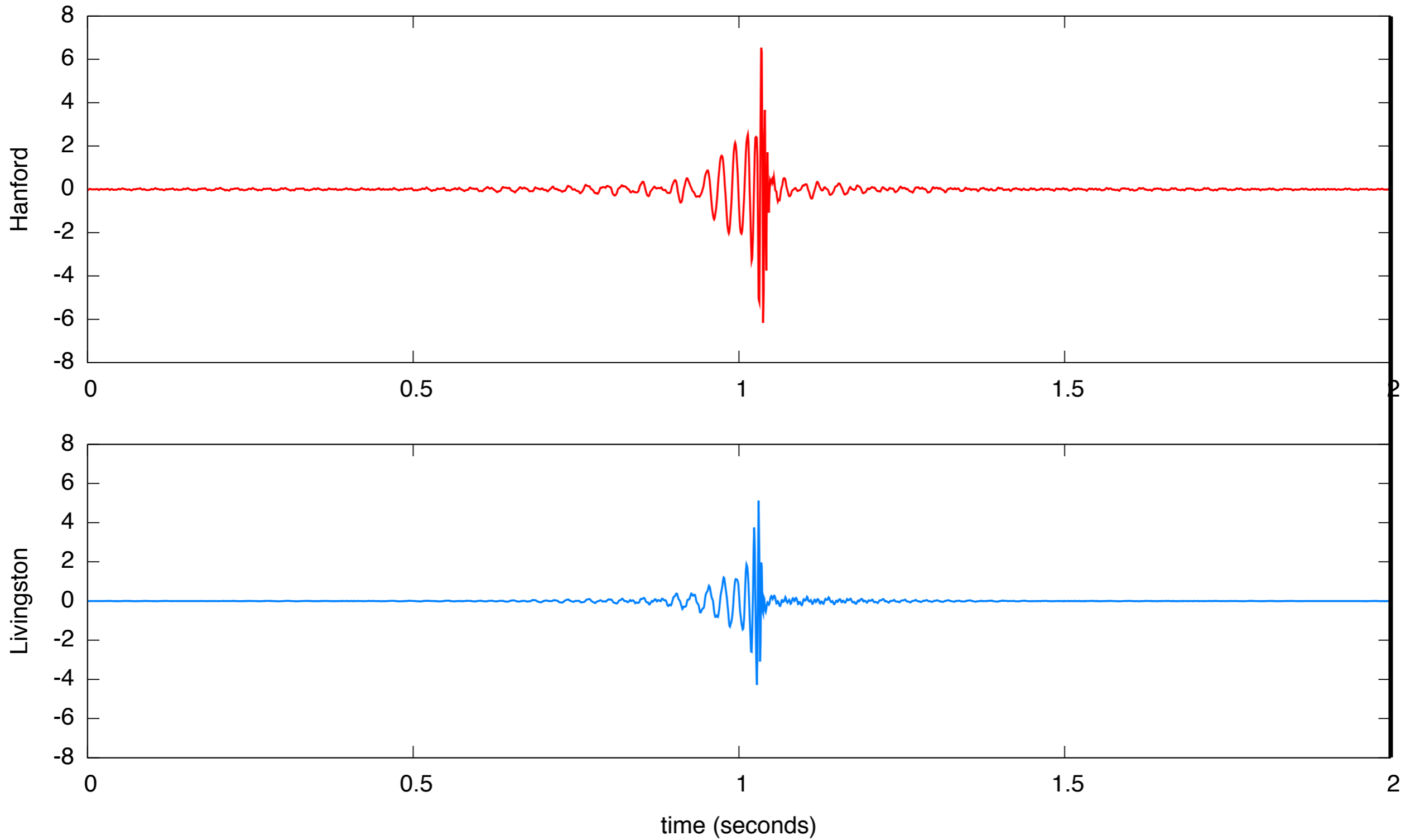

GW150914

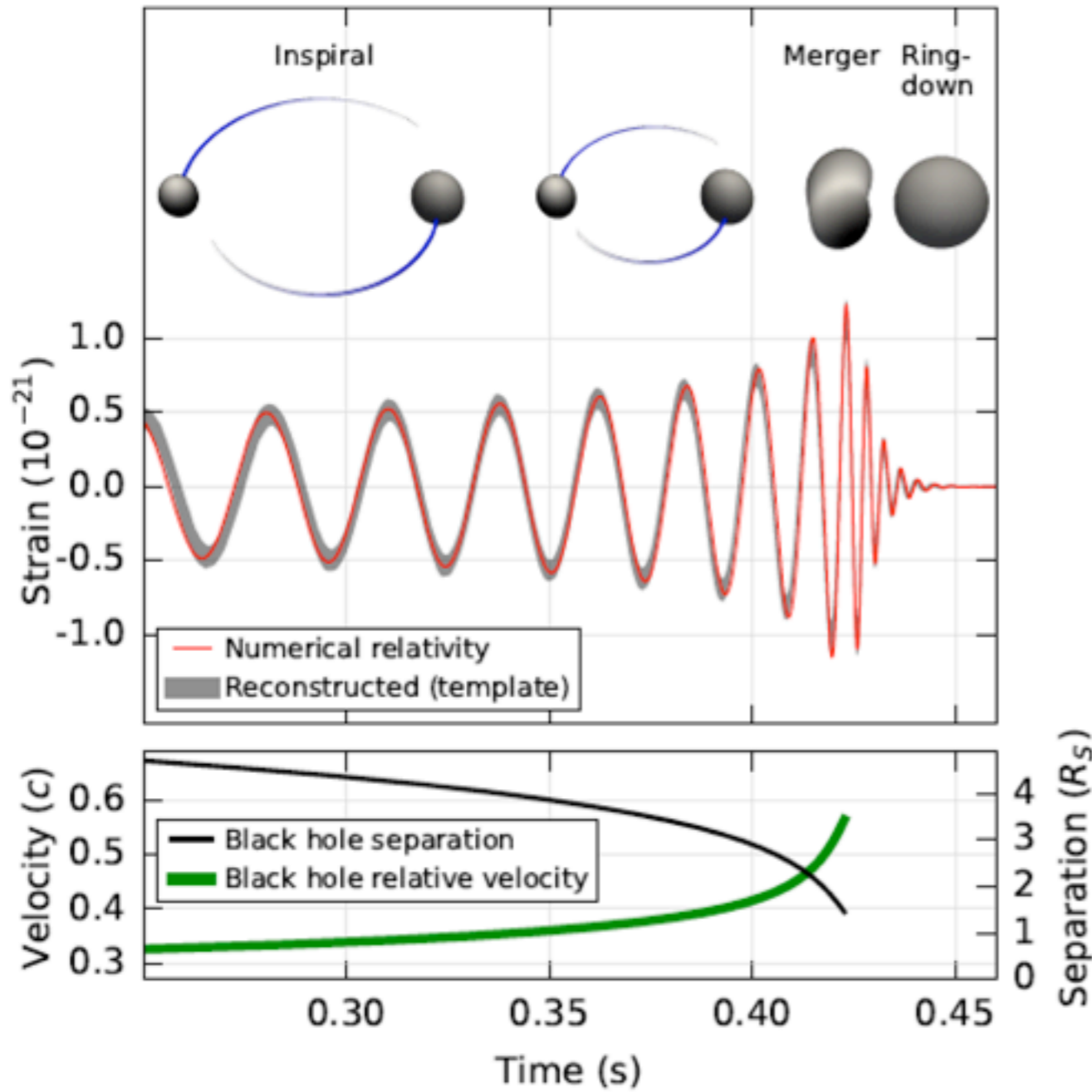

Primary black hole mass	$36^{+5}_{-4} M_{\odot}$
Secondary black hole mass	$29^{+4}_{-4} M_{\odot}$
Final black hole mass	$62^{+4}_{-4} M_{\odot}$
Final black hole spin	$0.67^{+0.05}_{-0.07}$
Luminosity distance	$410^{+160}_{-180} \text{ Mpc}$
Source redshift, z	$0.09^{+0.03}_{-0.04}$

Three Suns turned
into energy in a
fraction of a second!

Physical Properties of the remaining Black Hole

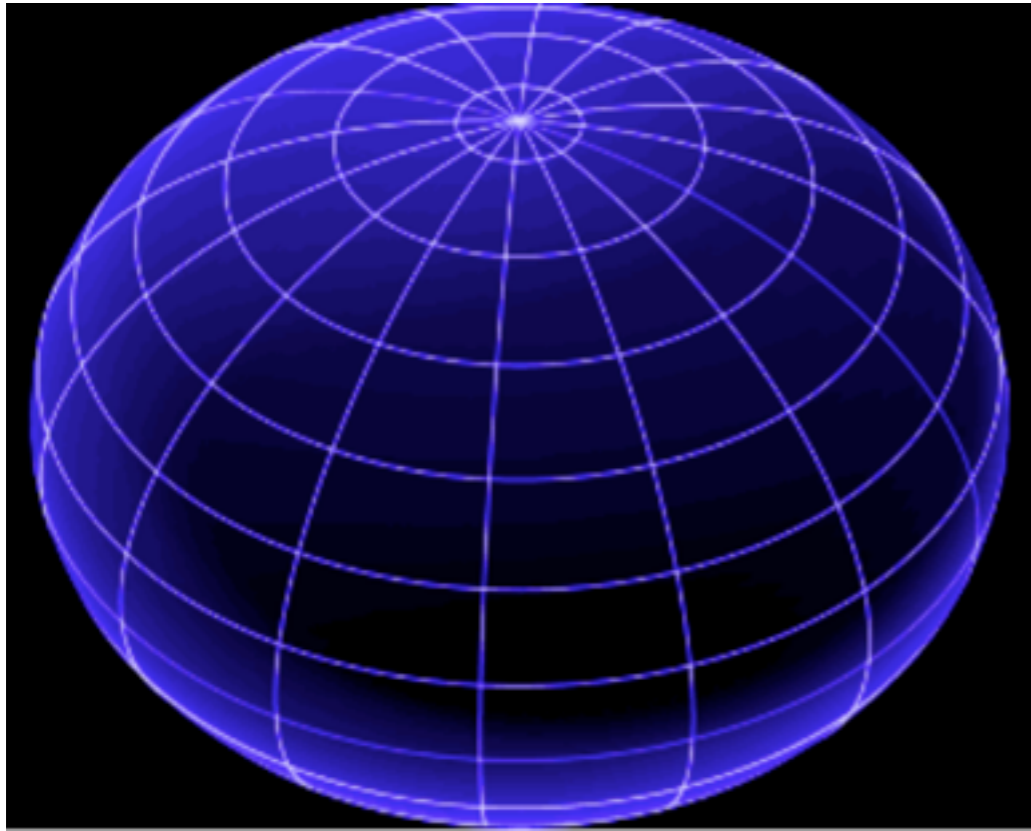

$$A_H = 8\pi M^2 \left(1 + \sqrt{1 - \chi^2}\right)$$

Surface Area

370,000 km²

380,000 km²

Physical Properties of the remaining Black Hole

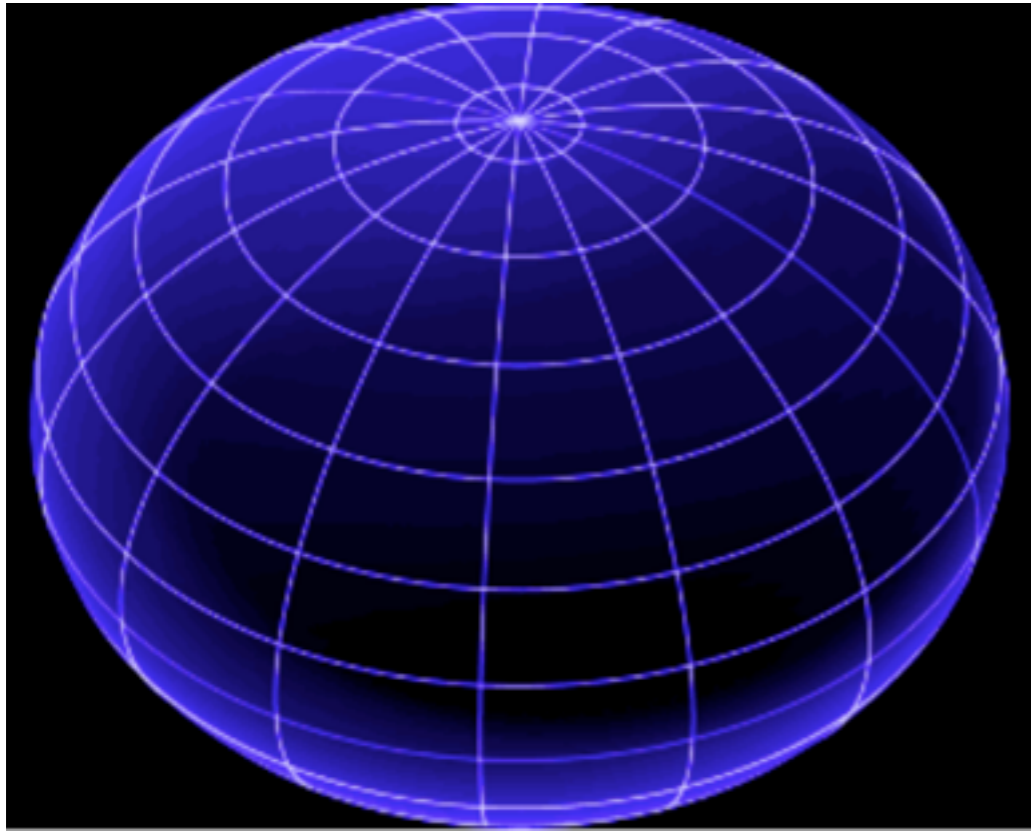

$$\Omega_H = \frac{\chi}{2M \left(1 + \sqrt{1 - \chi^2}\right)}$$

Rotation Rate

100 rev/sec

1 rev/day

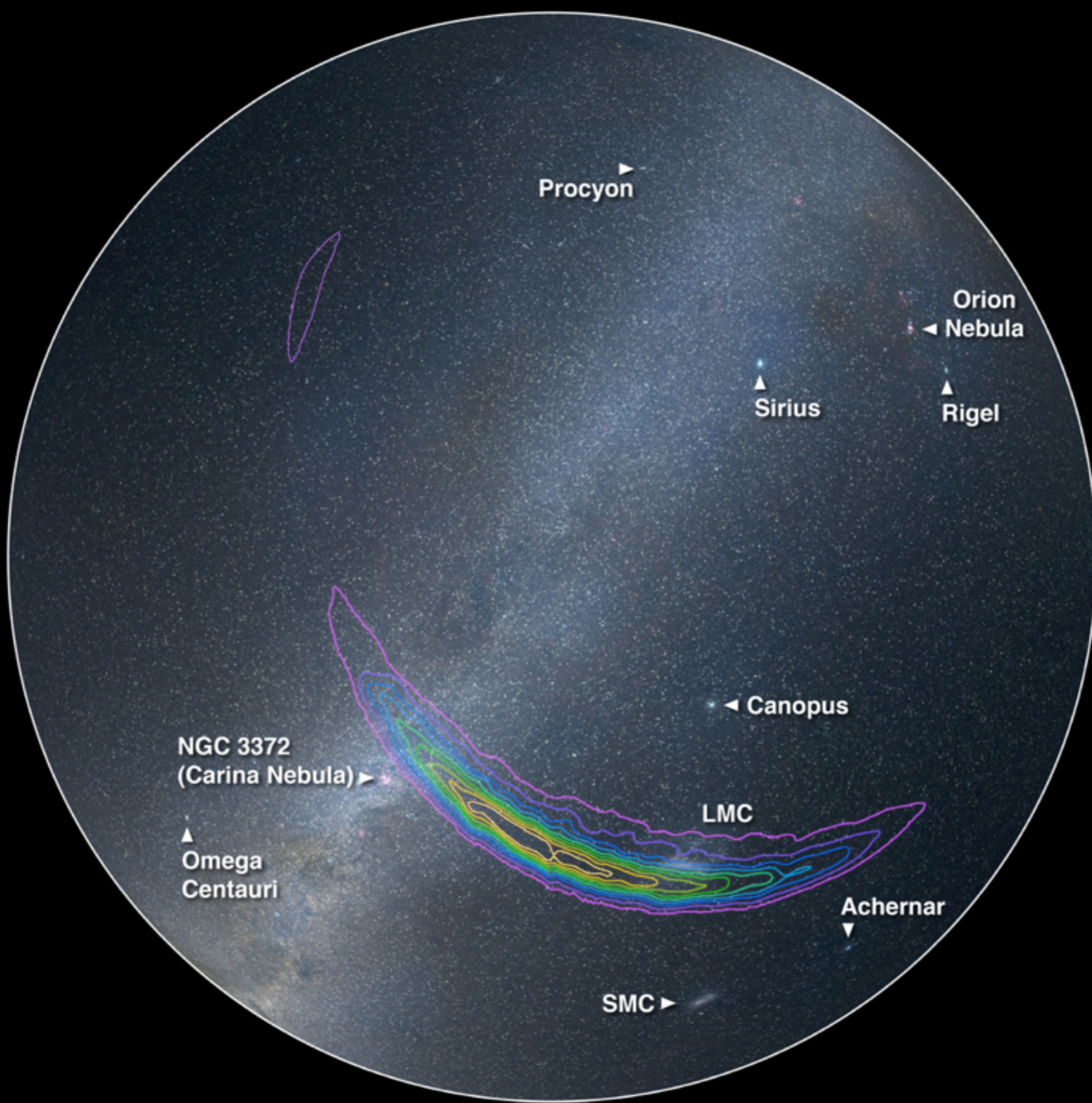

Procyon

Orion
Nebula

Sirius

Rigel

Canopus

NGC 3372
(Carina Nebula)

Omega
Centauri

LMC

Achernar

SMC

Electromagnetic Follow-up Campaign for GW150914

[arXiv:1602.08492]

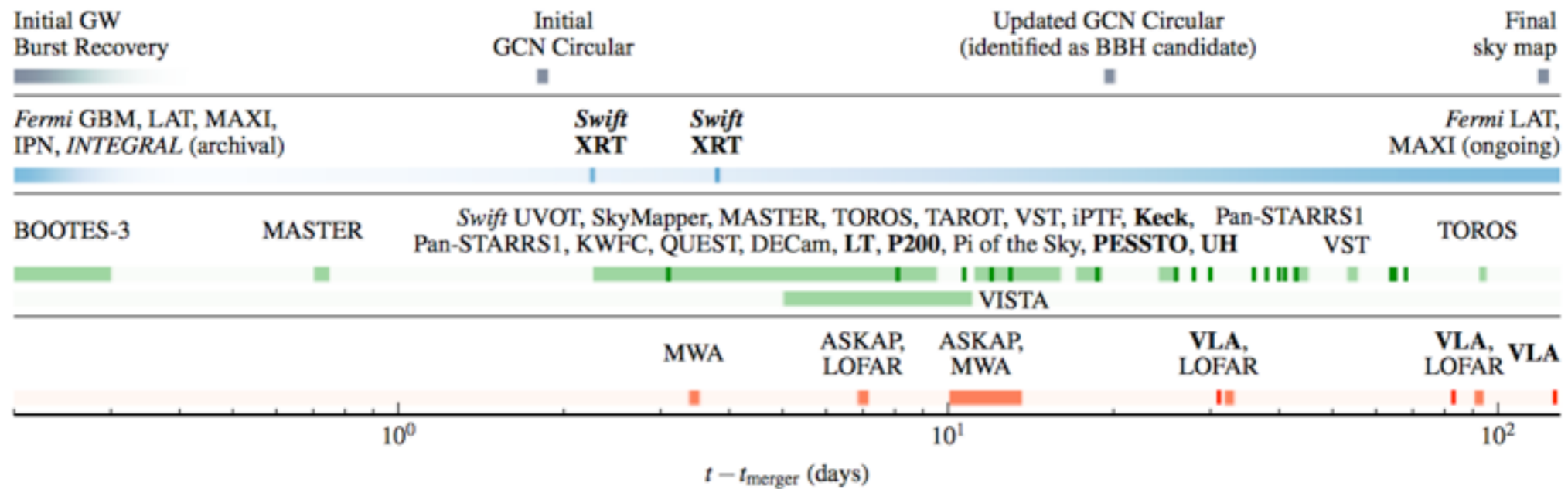
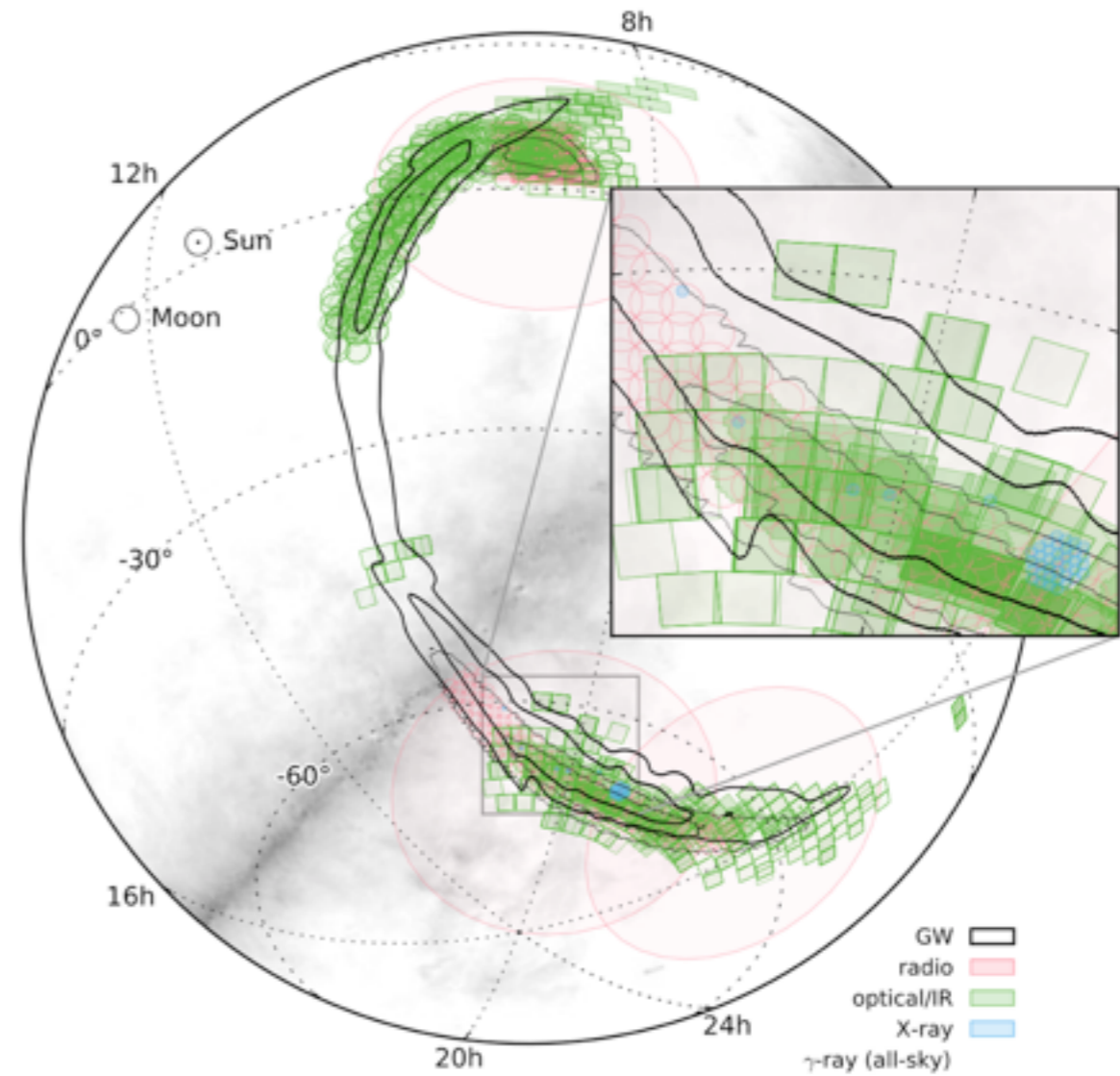

Triangulating the Source



Terrestrial Network

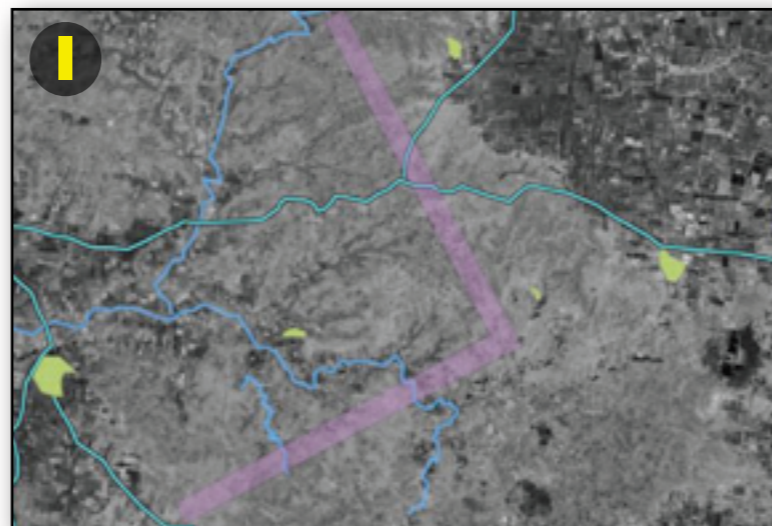
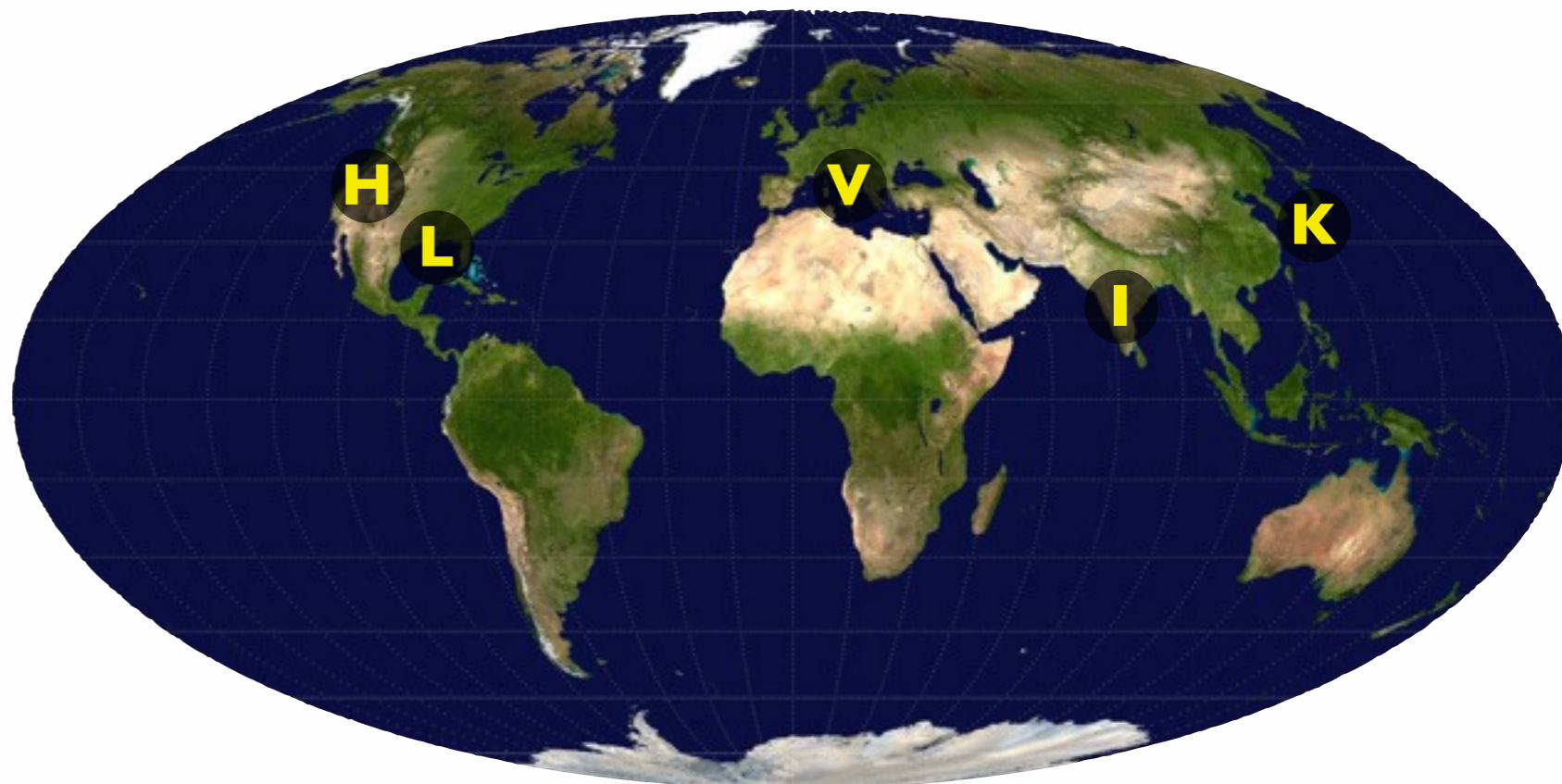

Terrestrial Network

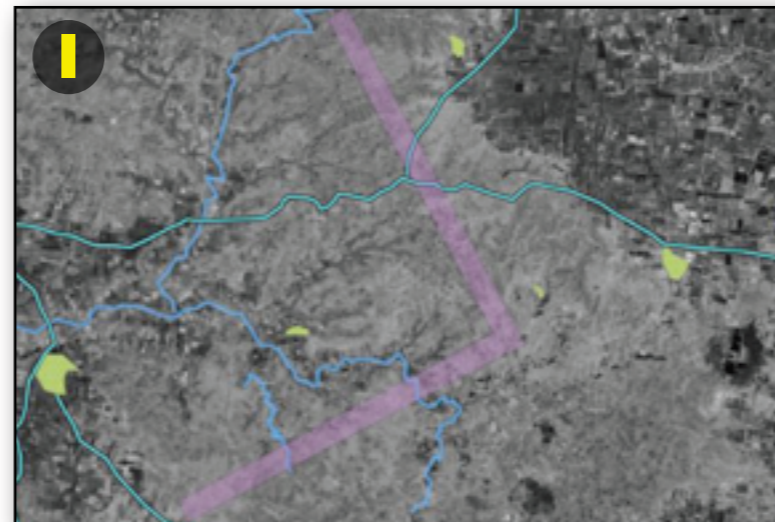
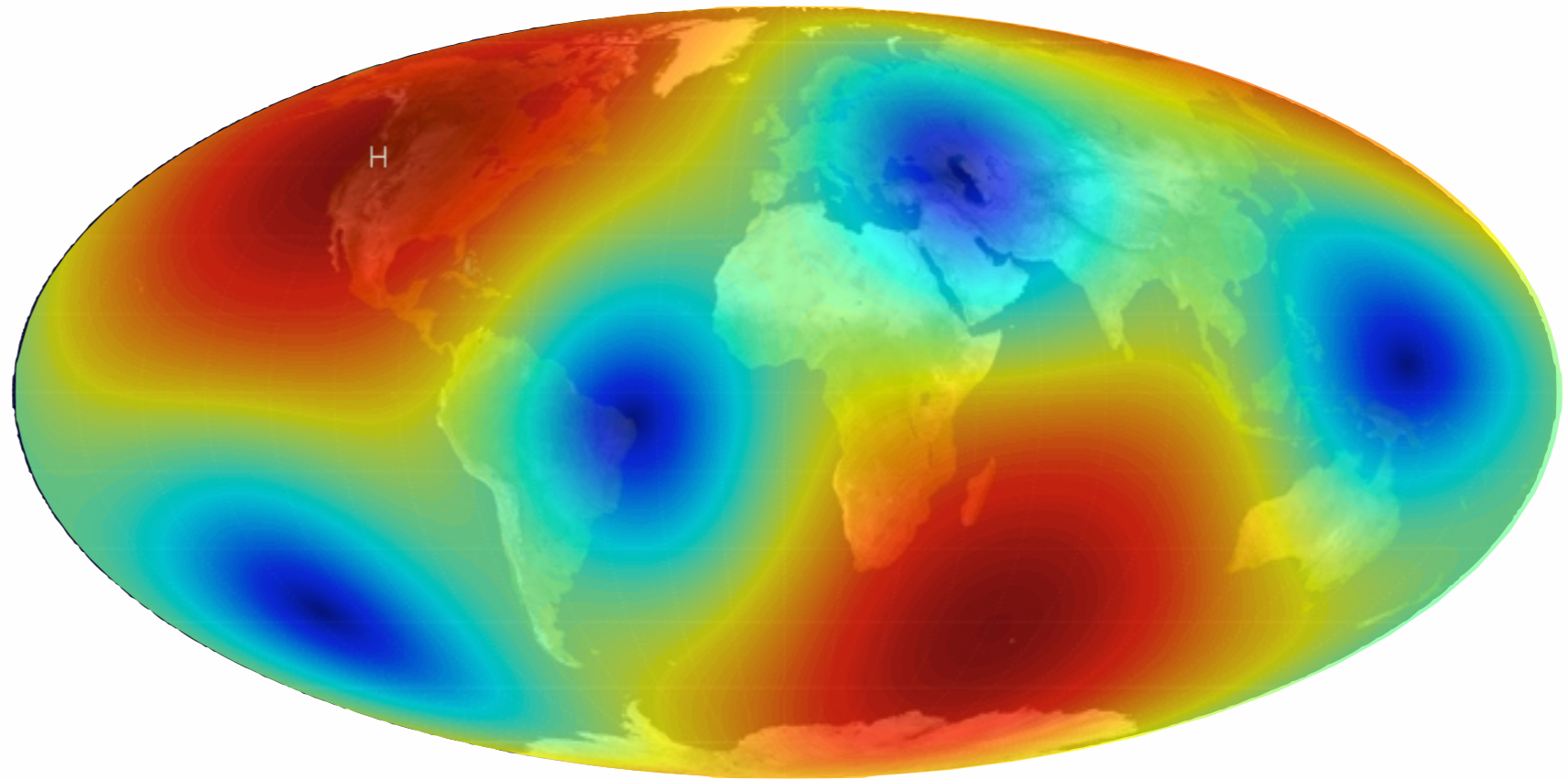

Terrestrial Network

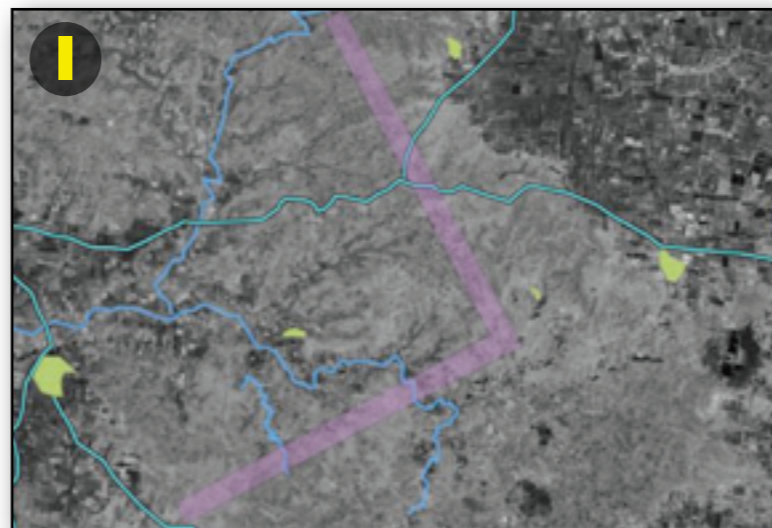
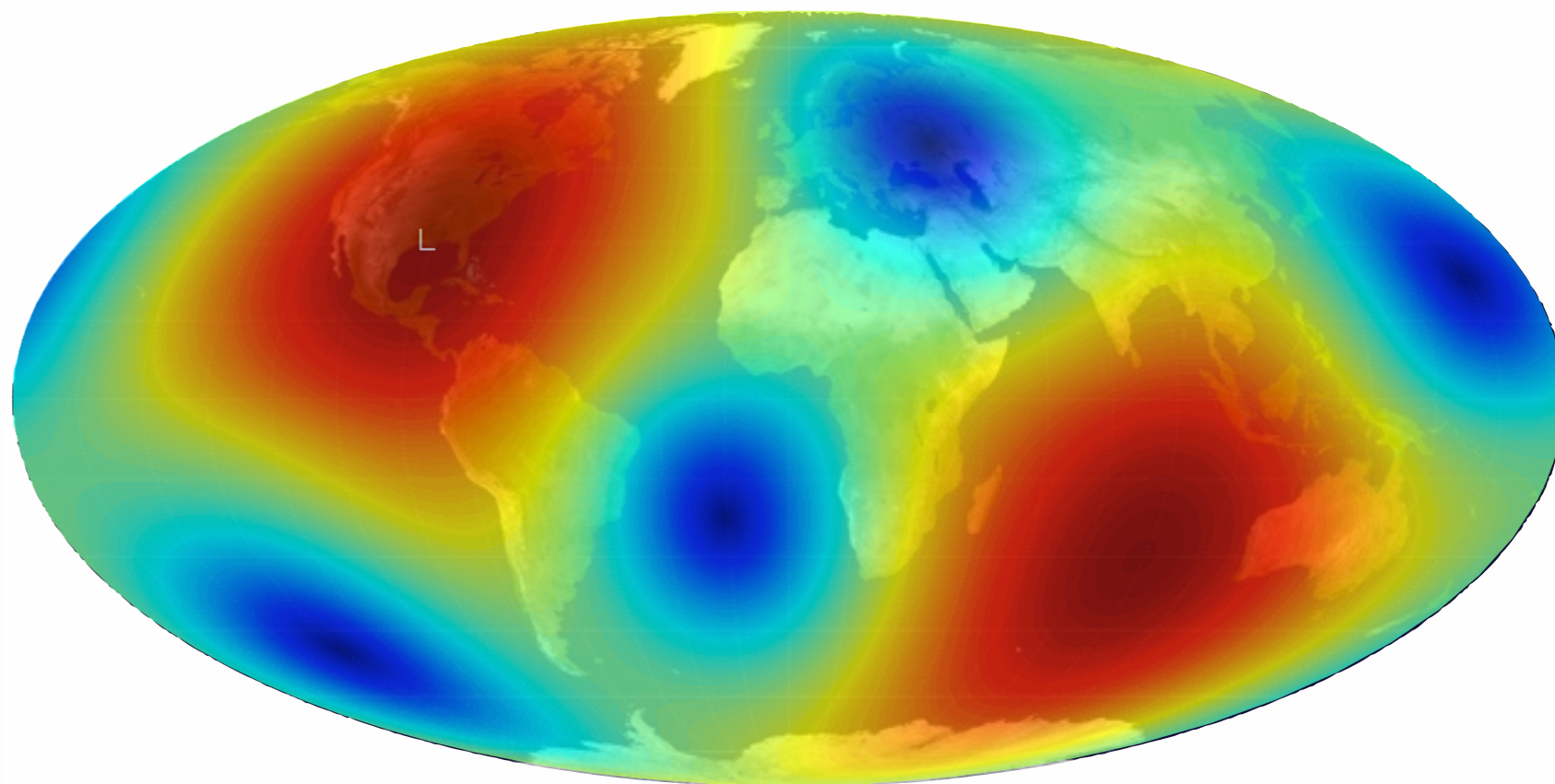

Terrestrial Network

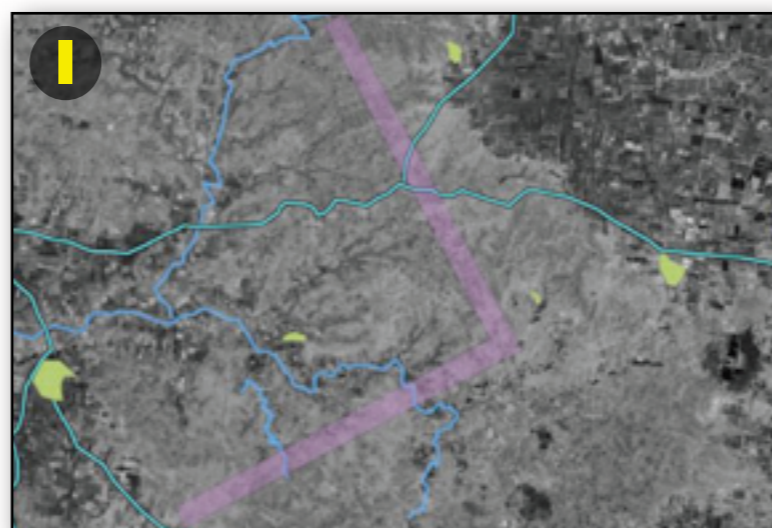
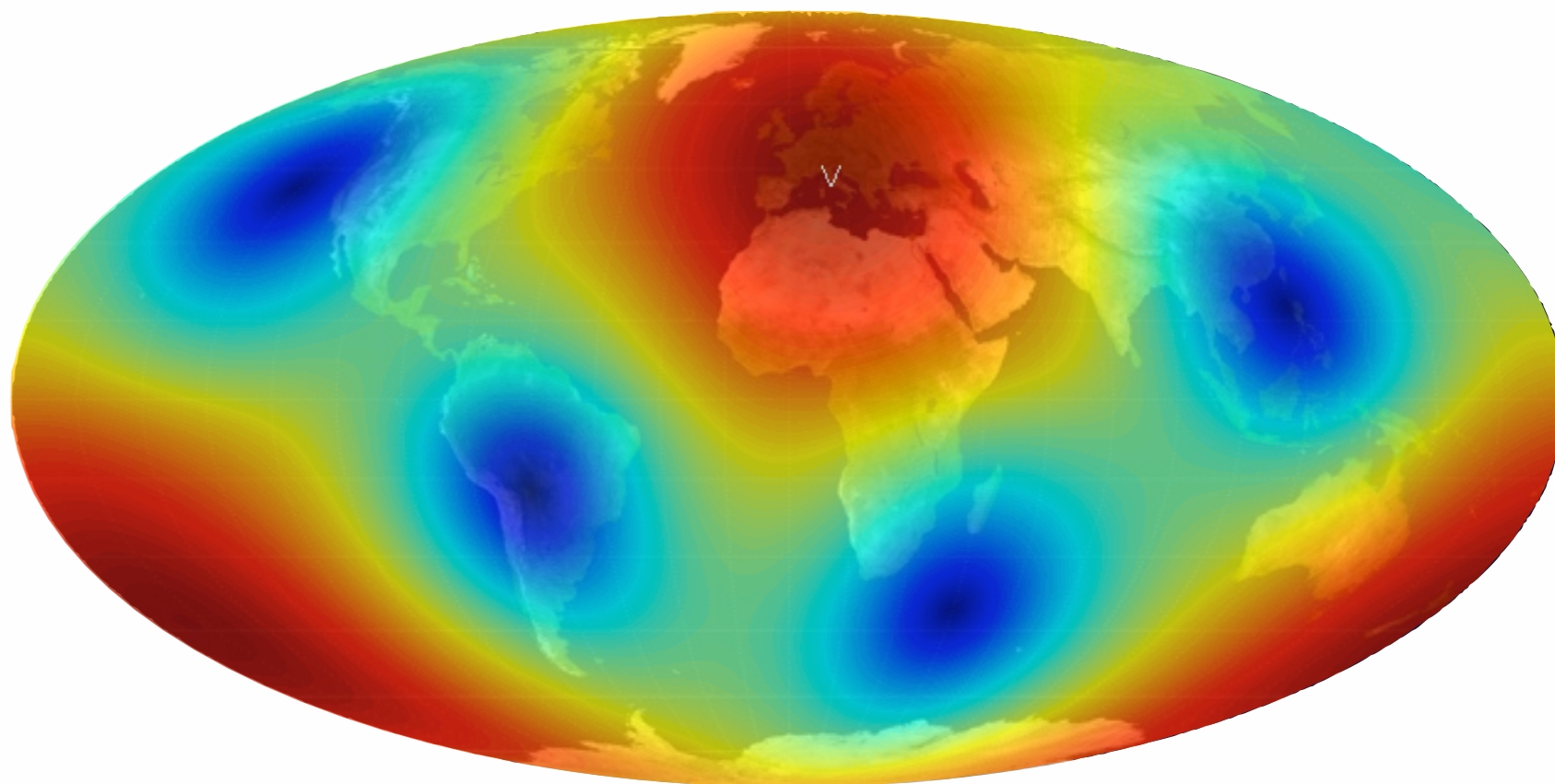

Terrestrial Network

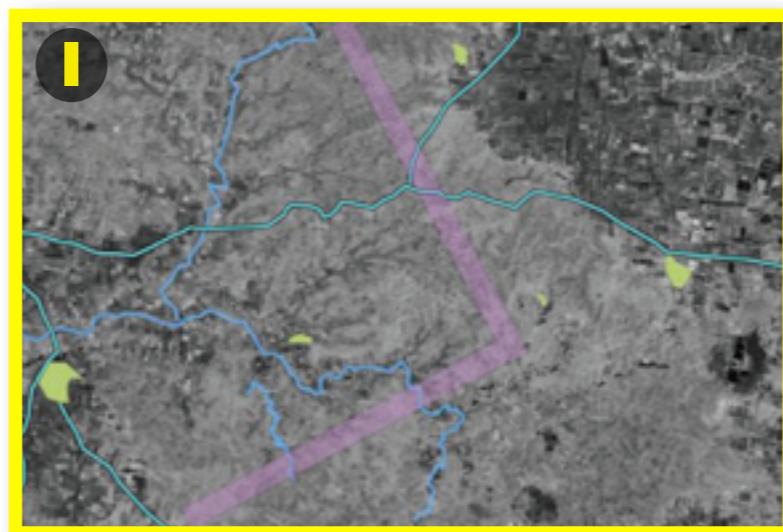
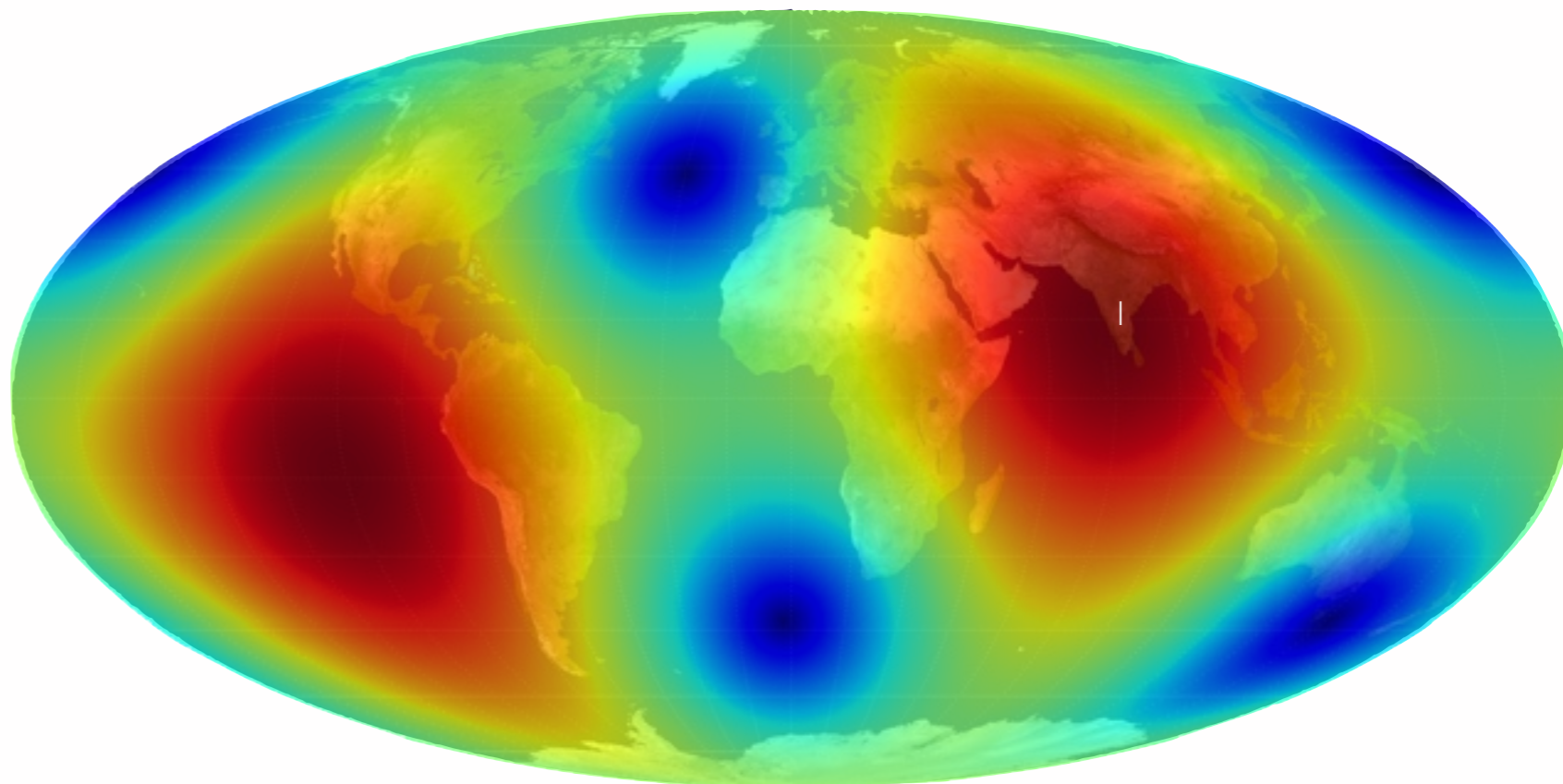

Terrestrial Network

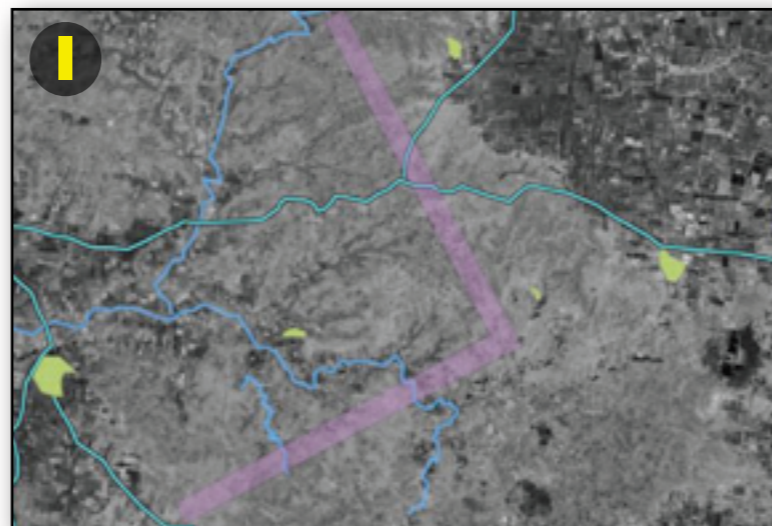
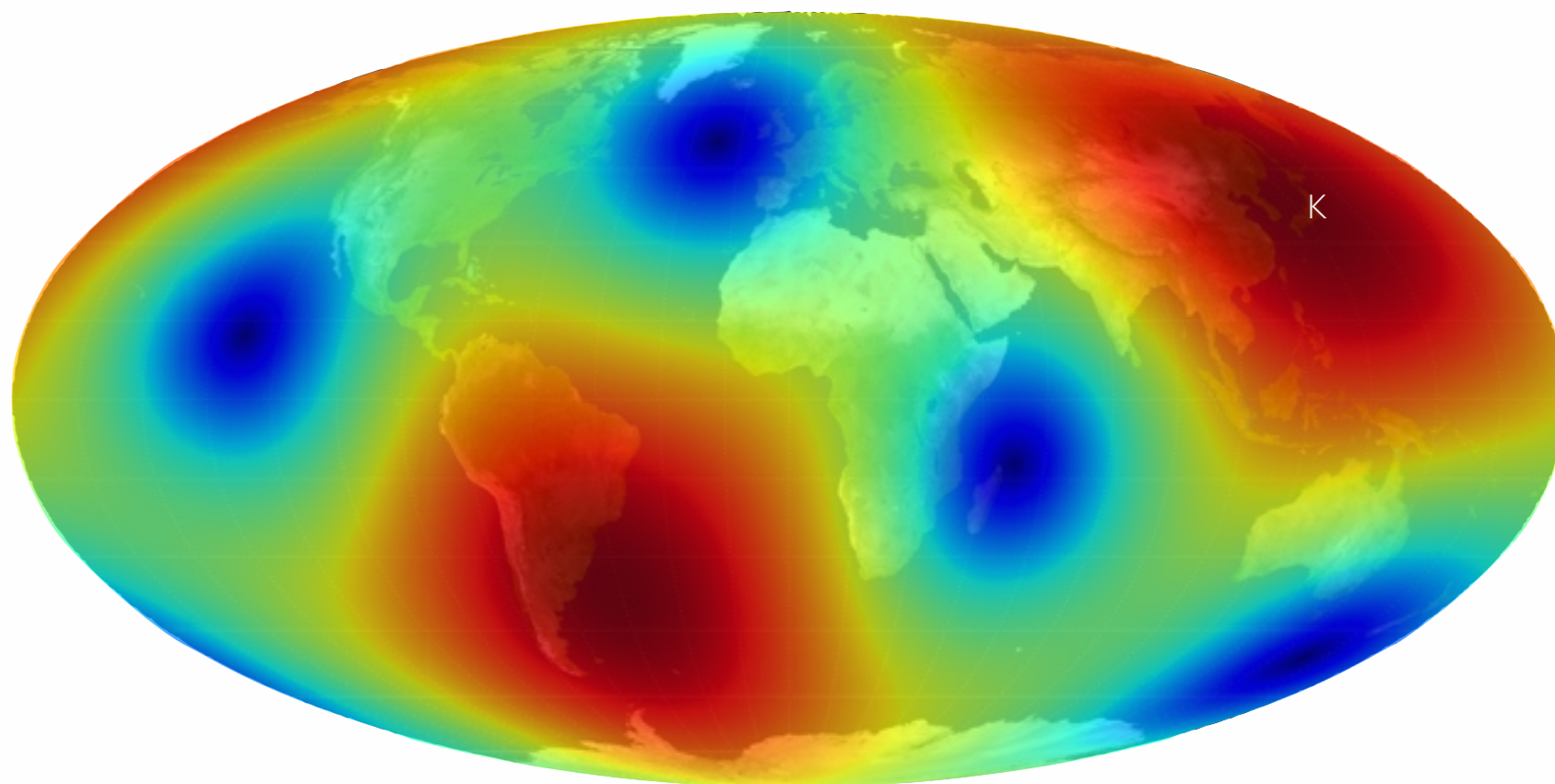

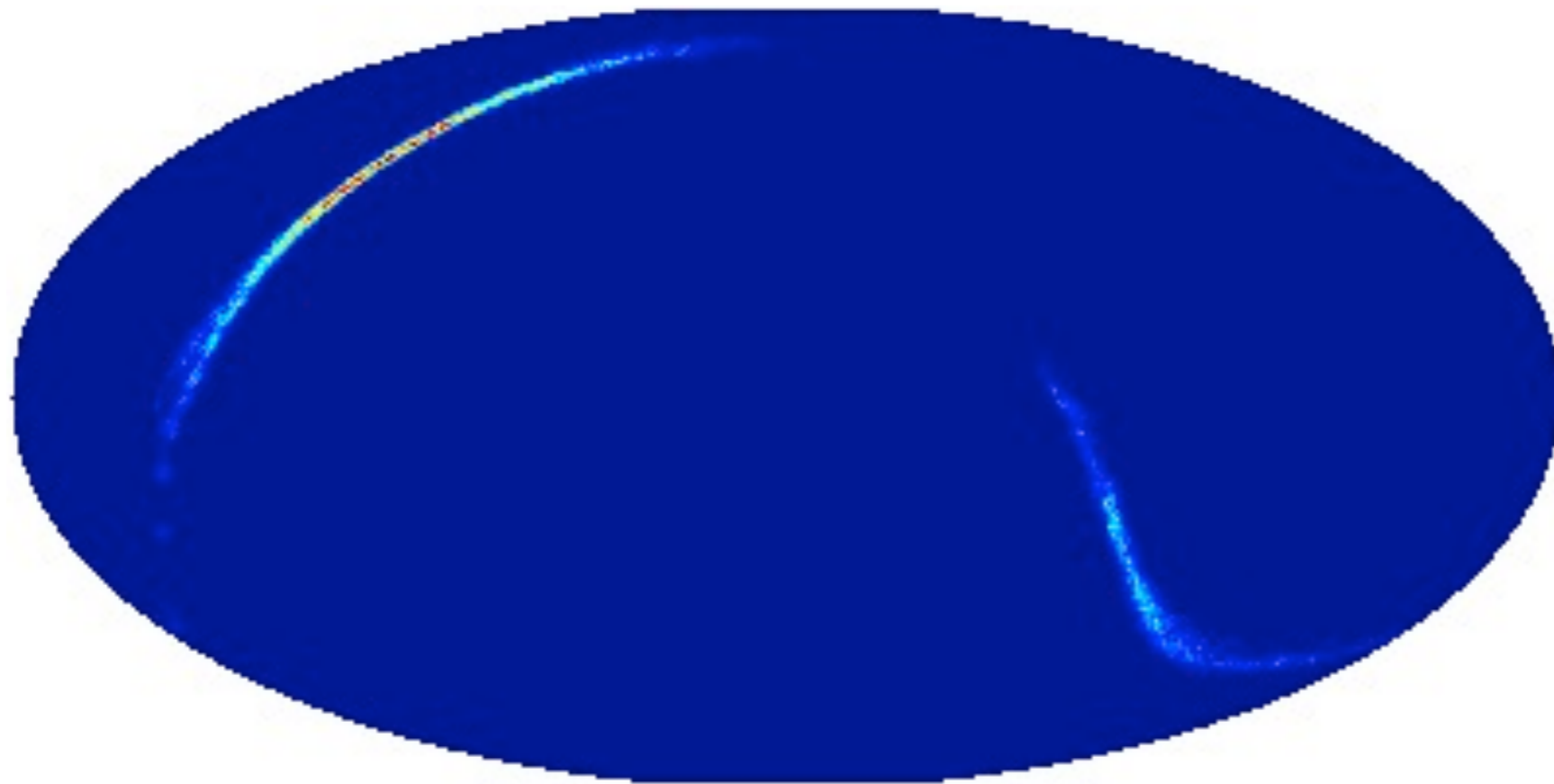

LHO-LLO

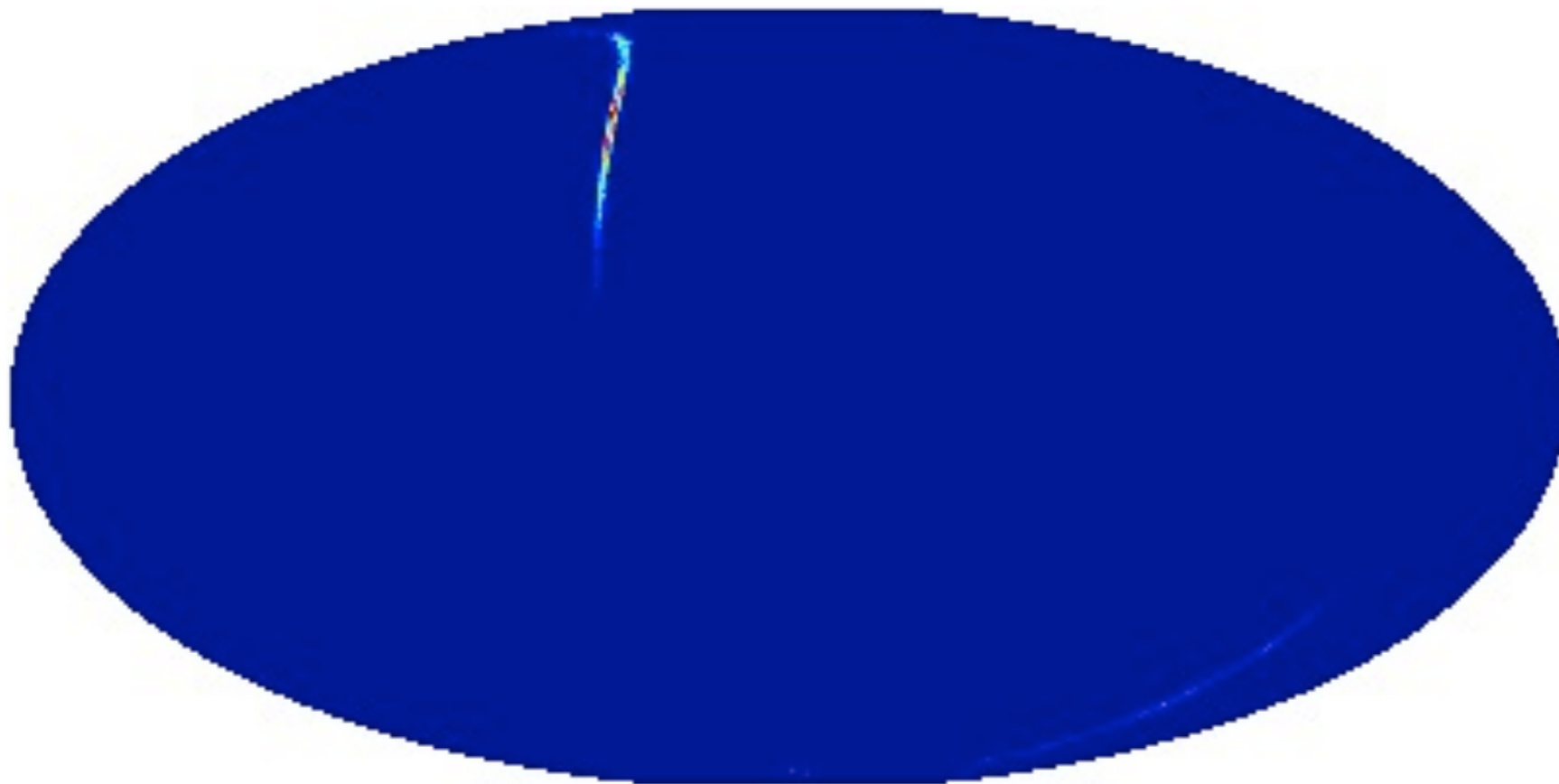

LLO-Virgo

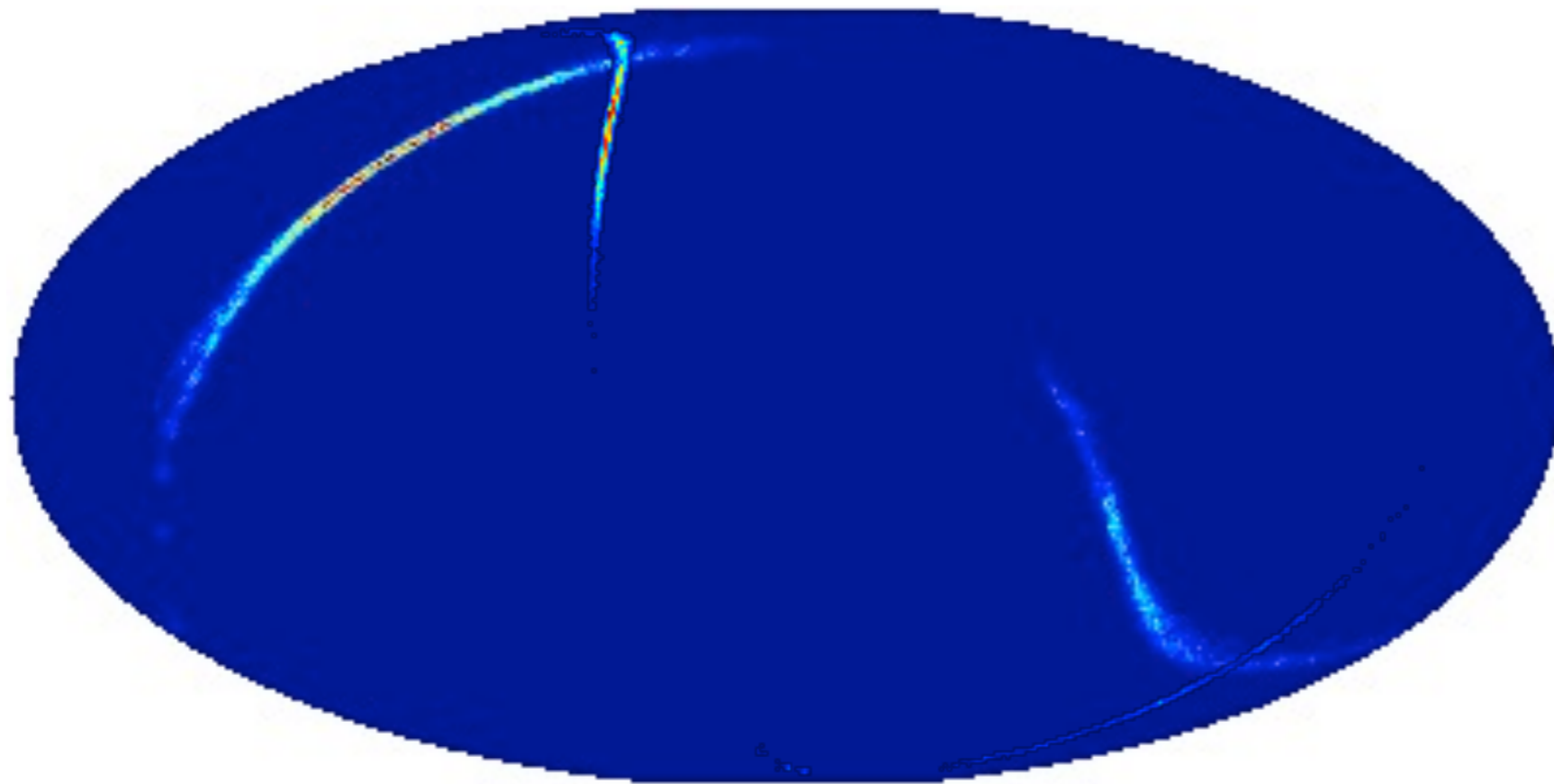

LHO-LLO
LLO-Virgo
(overlaid)

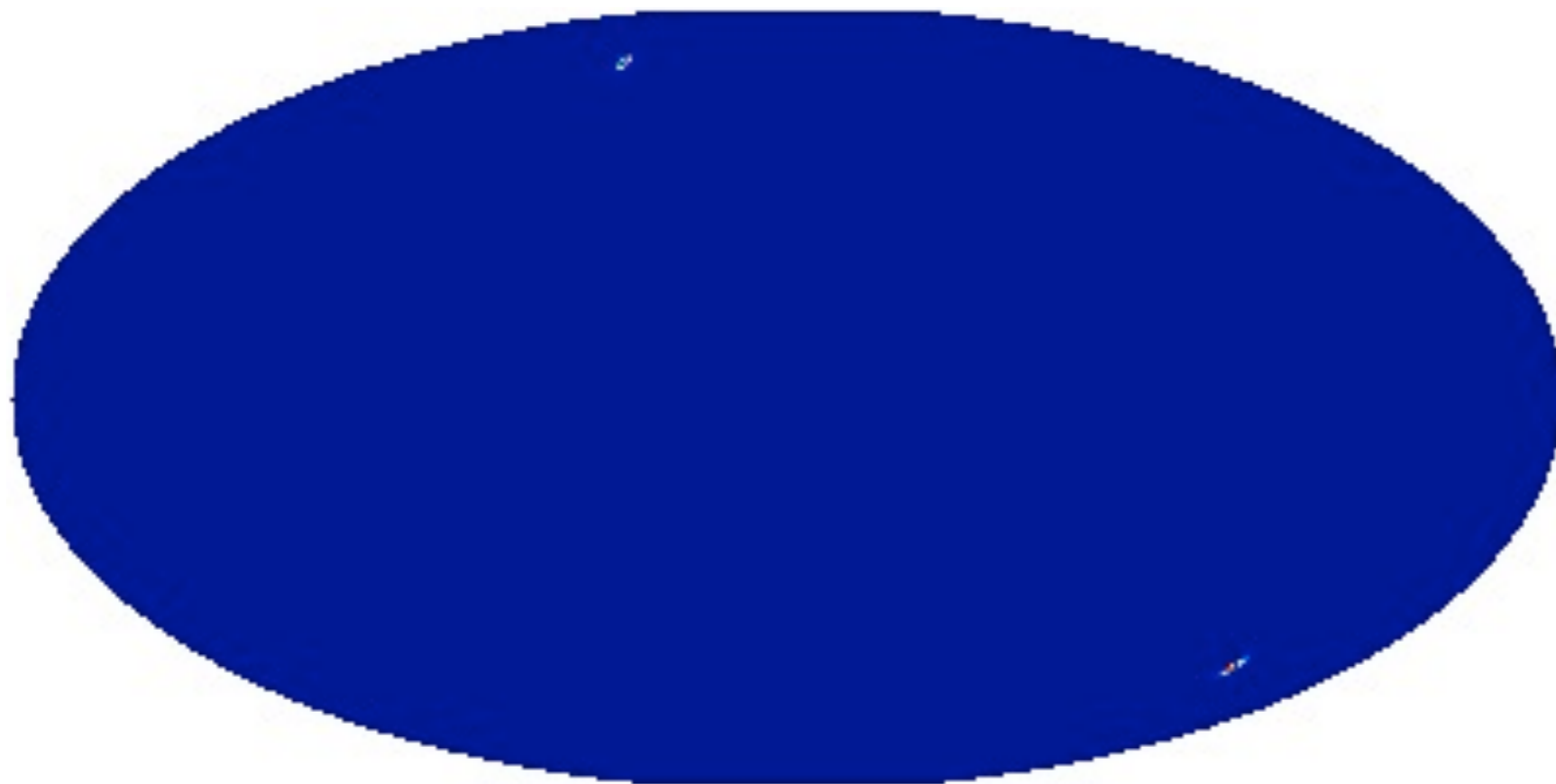

LHO-LLO-Virgo

LIGO/Virgo Sky Localization - NS-NS mergers

2016-17

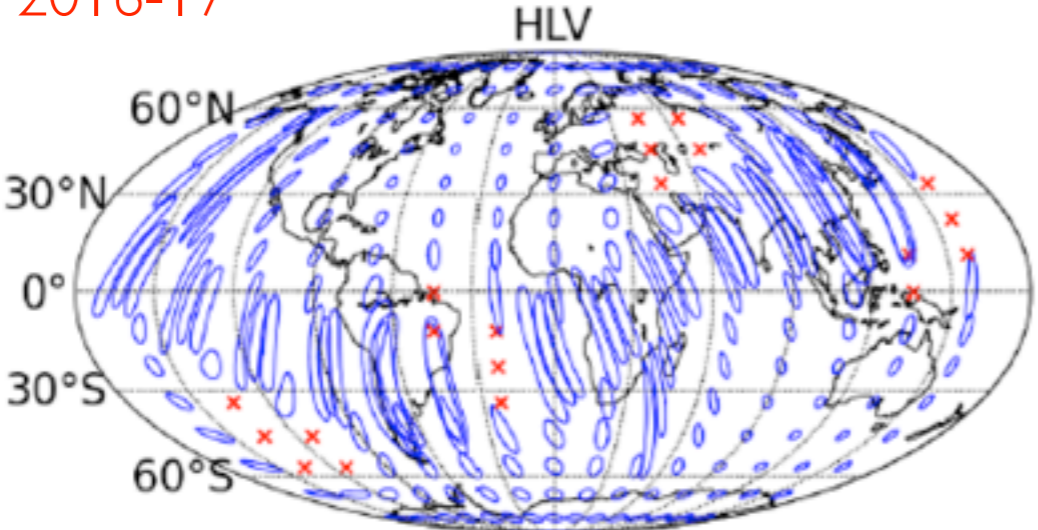

2017-18

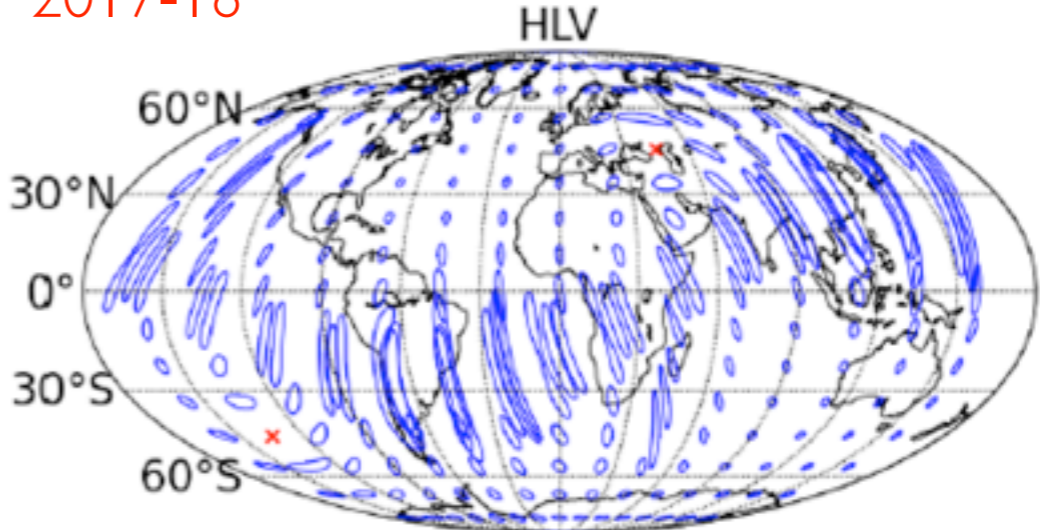

2019-21

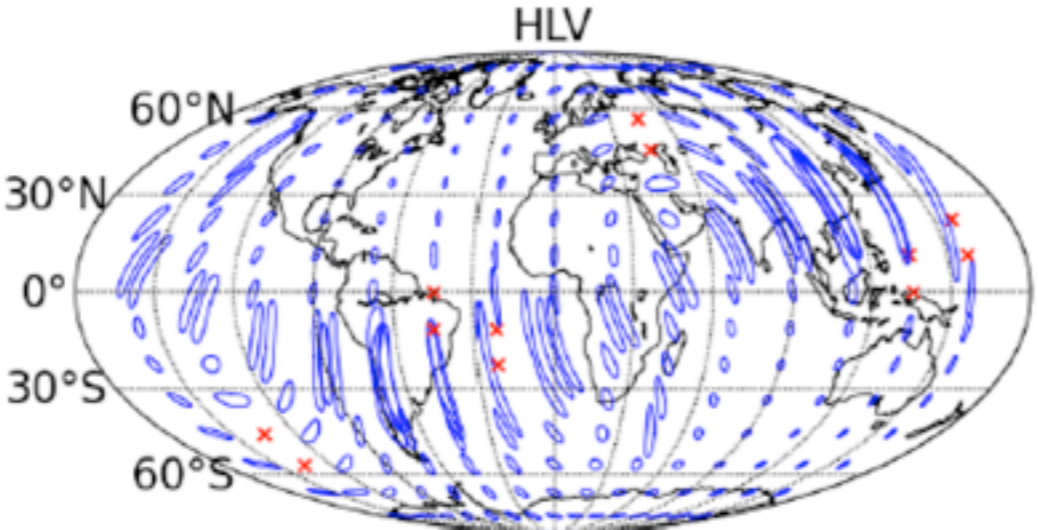

2023+

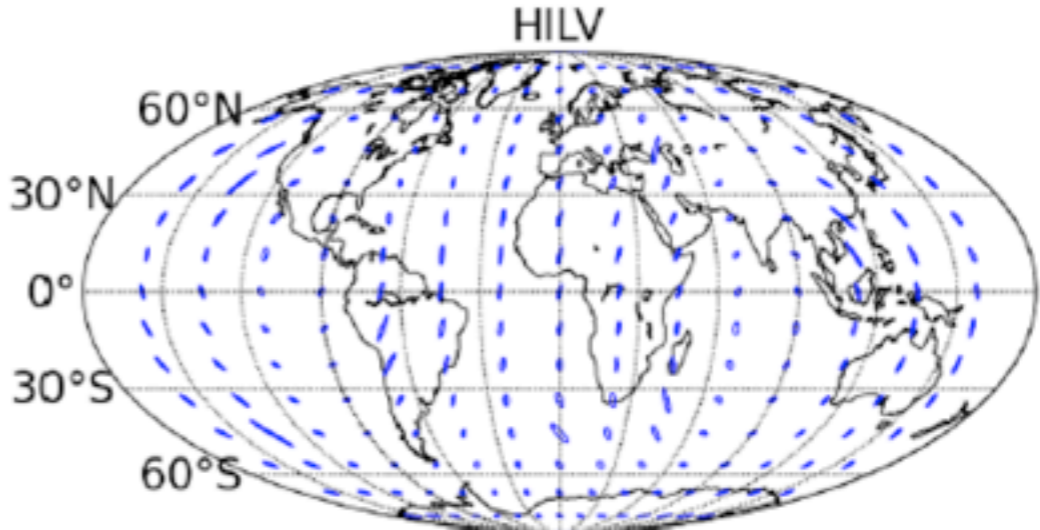

[LIGO-Virgo arXiv:1304.0670]

EM Counterparts..... Matter Required!

- NS-NS Mergers
- NS-BH Mergers
- Core Collapse Supernovae
- Collapsars/Hypernovae
- Pulsars
- LMXBs
- BH-BH Mergers (with some kind of gas inflow)

Electromagnetic Counterparts

Discovery	Follow-up
<ul style="list-style-type: none">● all sky field of view● multi-wavelength● good localization● rapid notification	<ul style="list-style-type: none">● rapid response● wide field of view● precise localization● multi-wavelength

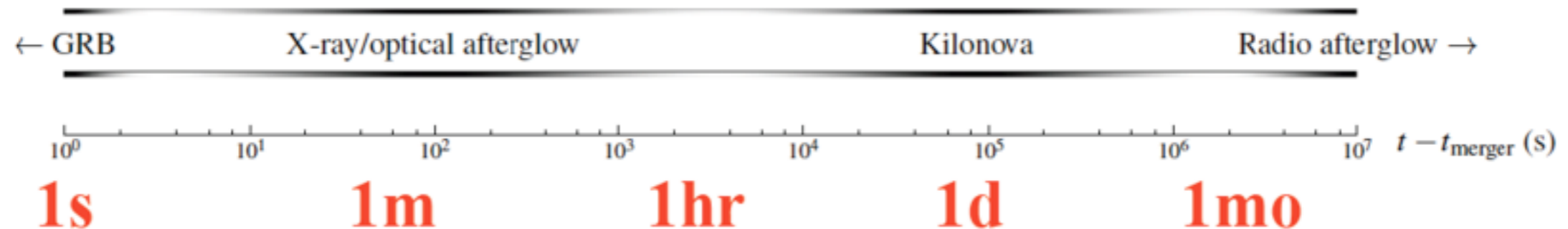

Singer et al. 2014

aLIGO Alerts

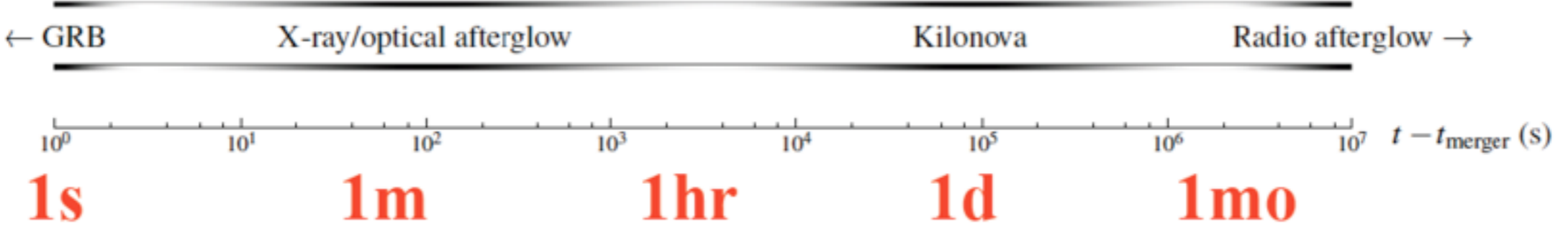

Singer et al. 2014

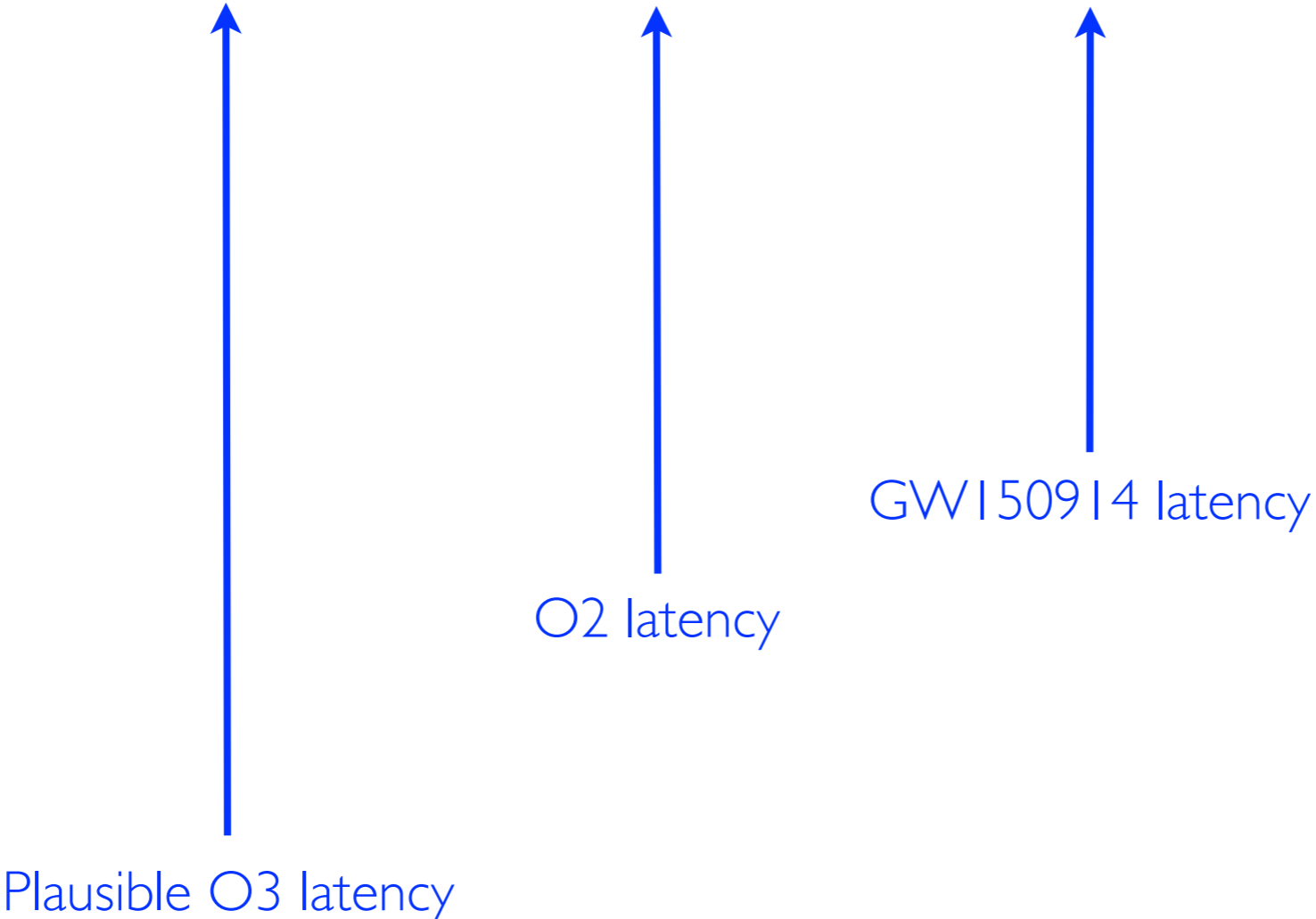

Selected high energy space missions

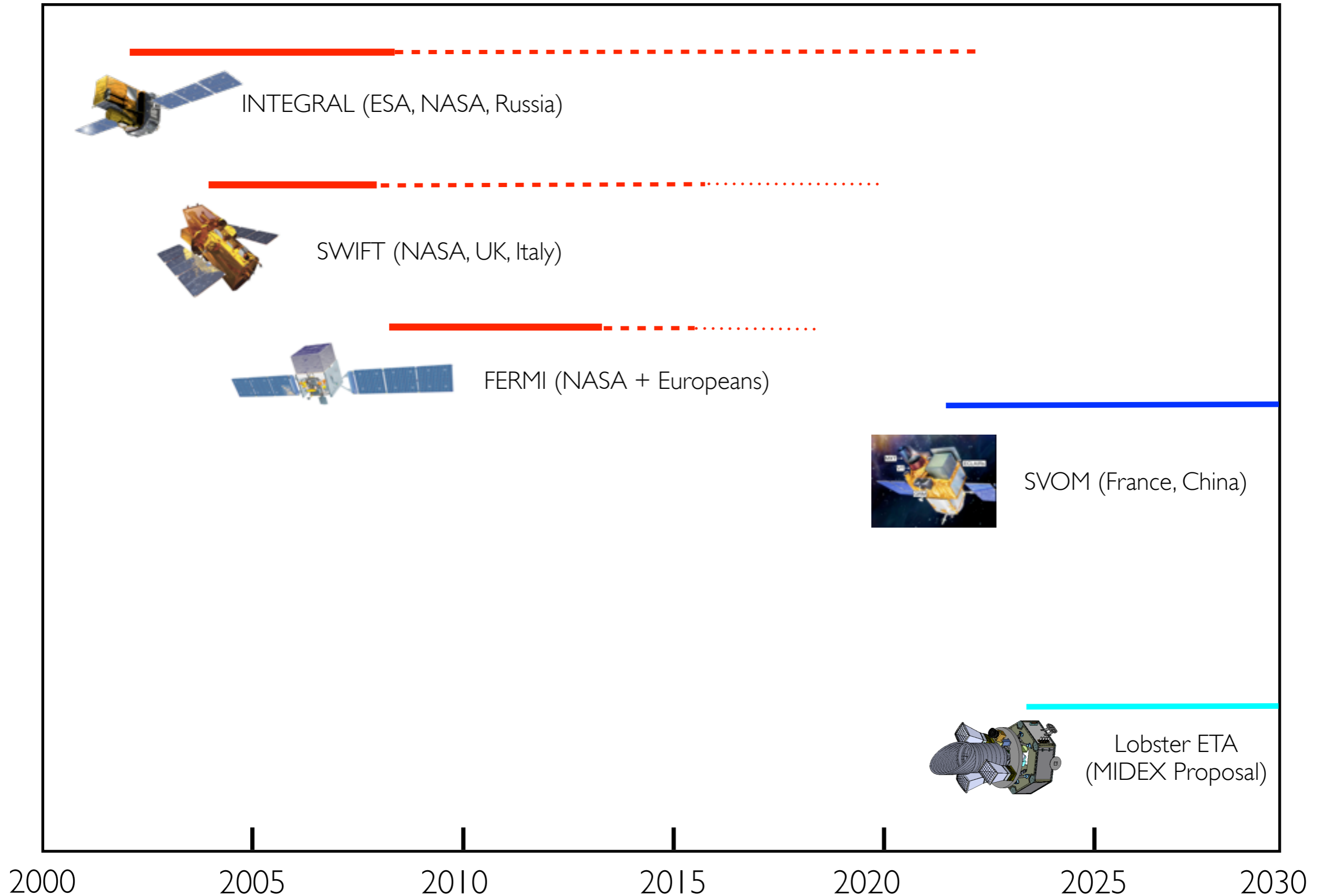

Selected high energy space missions

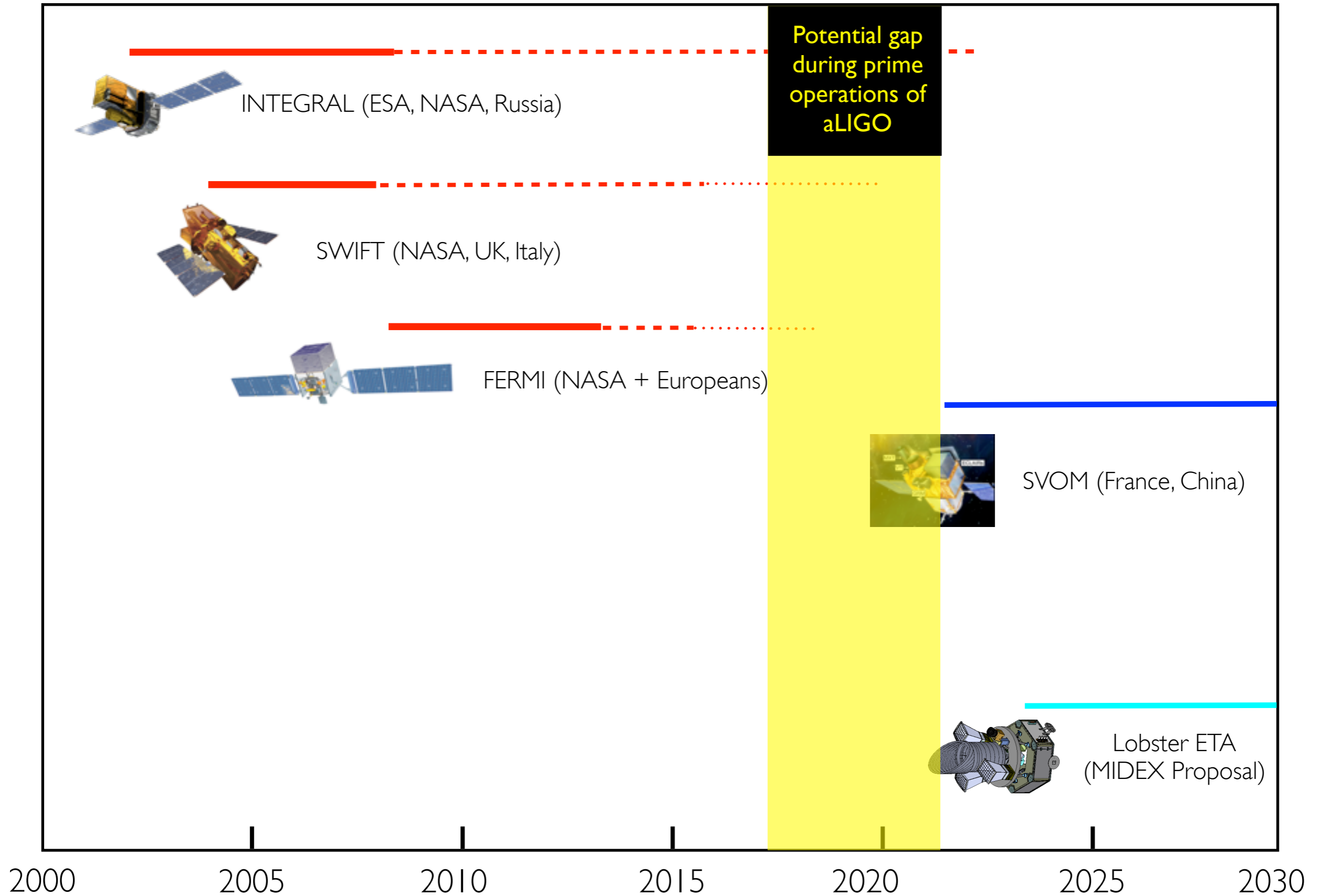

Selected high energy space missions

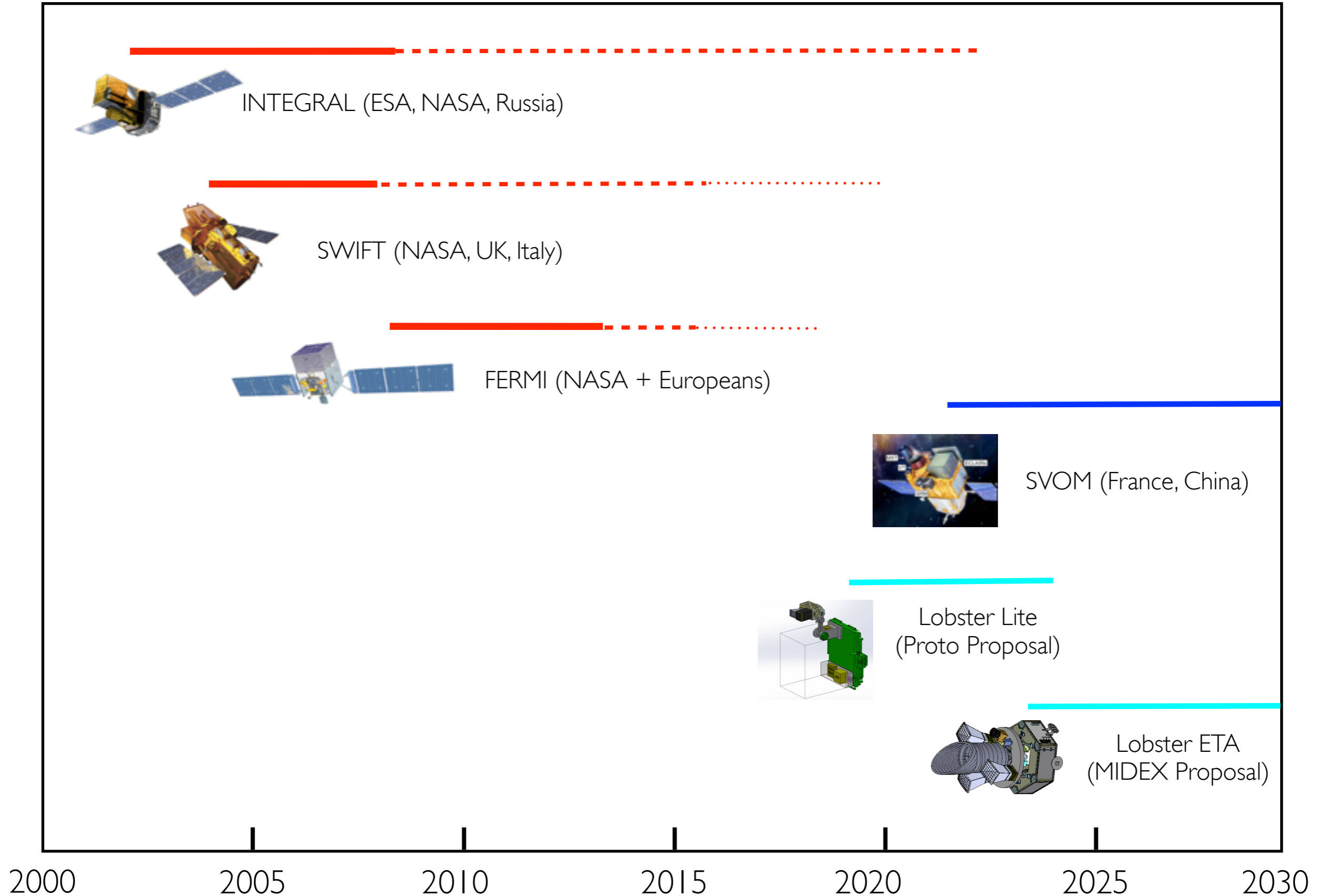

Explorer for Transient Astronomy Lobster ETA (2023+)

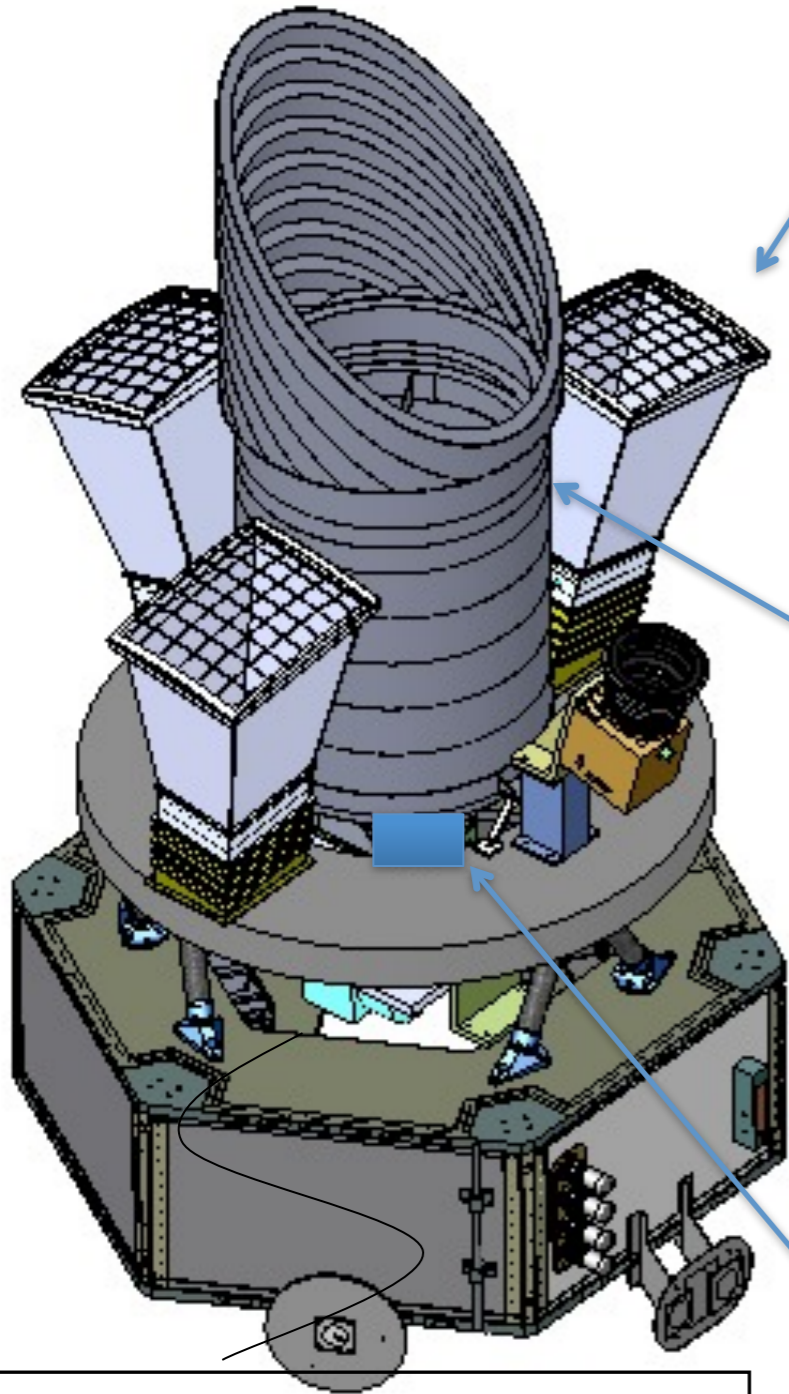

Spacecraft:
autonomous
rapid response

Wide Field Imager (WFI)

FoV: 1 steradian (8% of sky)

Sky coverage: 80% of sky every 1.5 hours

Energy Range: 0.3 - 6 keV

Detectors: CCDs

Optics: **Lobster-eye** microchannel optic

InfraRed Telescope (IRT)

Mirror Diameter: 40 cm

Wavelength Range: 0.6 – 2.1 microns

Detectors: HgCdTe

Multiband photometry, R=30 slit spectroscopy

Redshift determination on-board

Gamma-ray Transient Monitor (GTM)

Detectors: 3 x NaI scintillator (Fermi GBM size)

FoV: 8 steradians

Energy Range: 20 keV – 5 MeV

All technologies at TRL 6

Lobster Lite (Under Study)

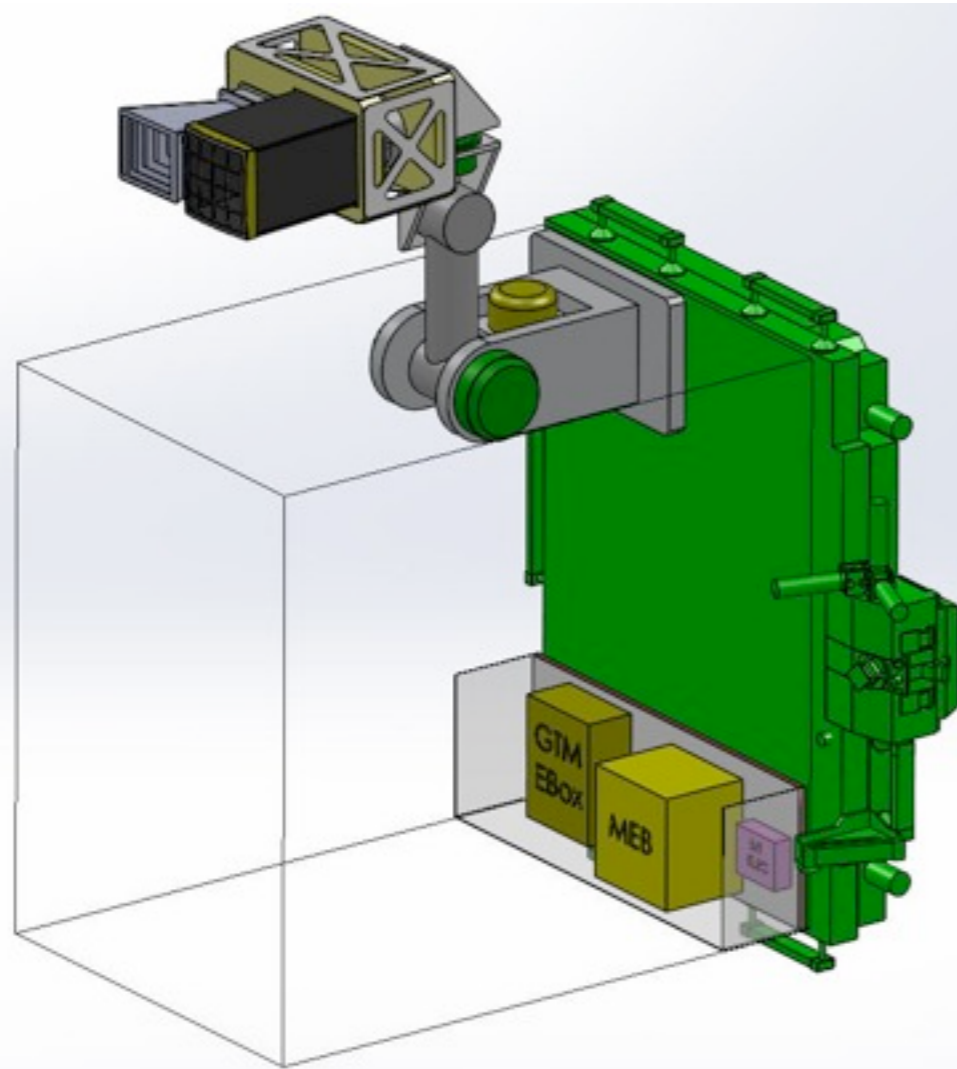

Descoped Field of View: 150 deg²

Air Force Space Test Program

Working with SSCO at Goddard

Leveraging RAVEN mission

GSFC
Israel Space Agency
Los Alamos Natl Lab

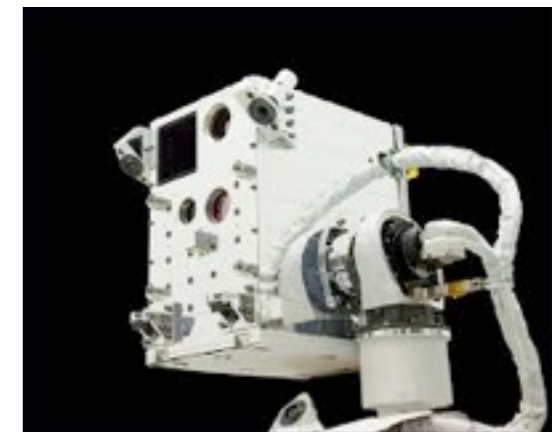

Operational in 2019 when LIGO at full sensitivity

Transient Astrophysics Probe

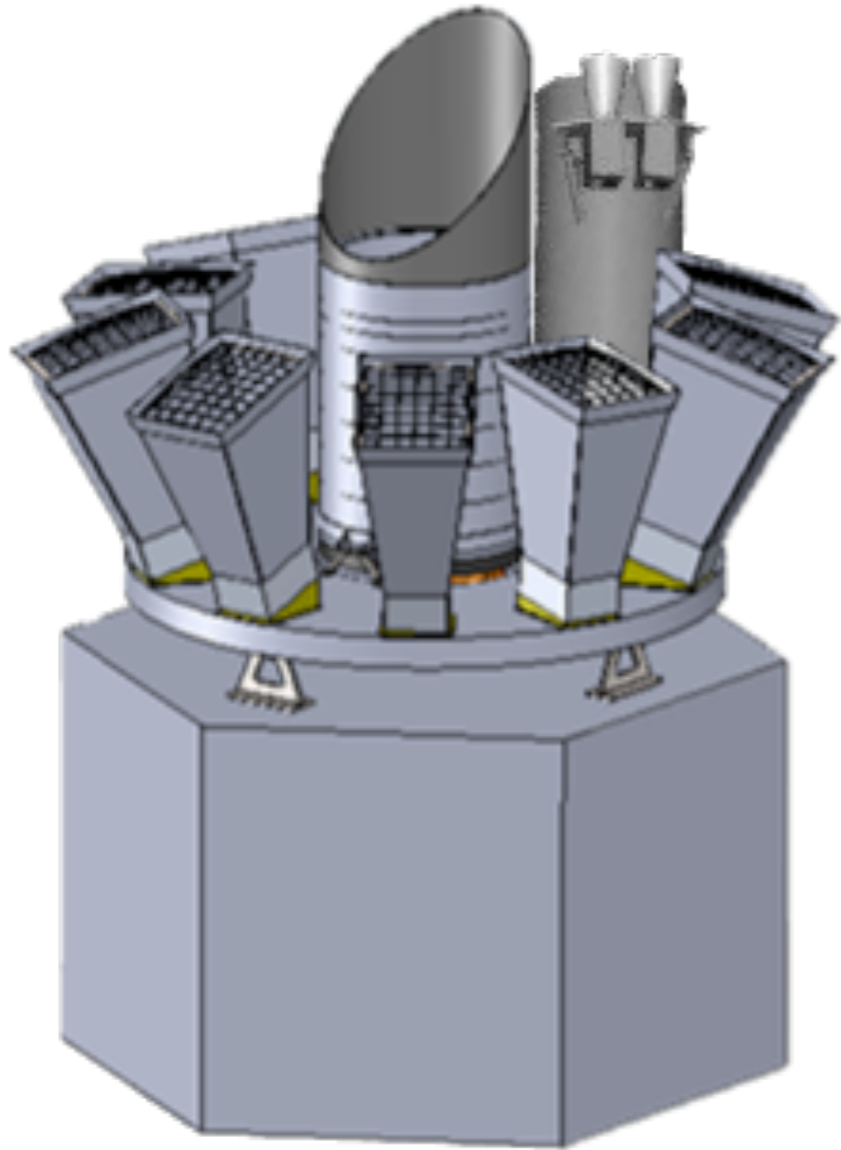

8 Lobster modules = 2 sr

IRT for WFI followup redshift measurement,
kilonova followup

X-ray Telescope: high sensitivity for WFI
and LISA followup (1deg² FoV)

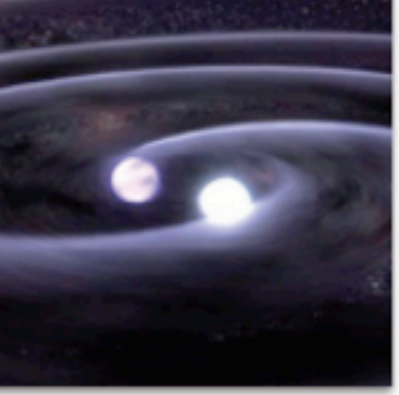

BurstCube: A CubeSat for Gravitational Wave Counterparts

PI: Jeremy Perkins (GSFC)

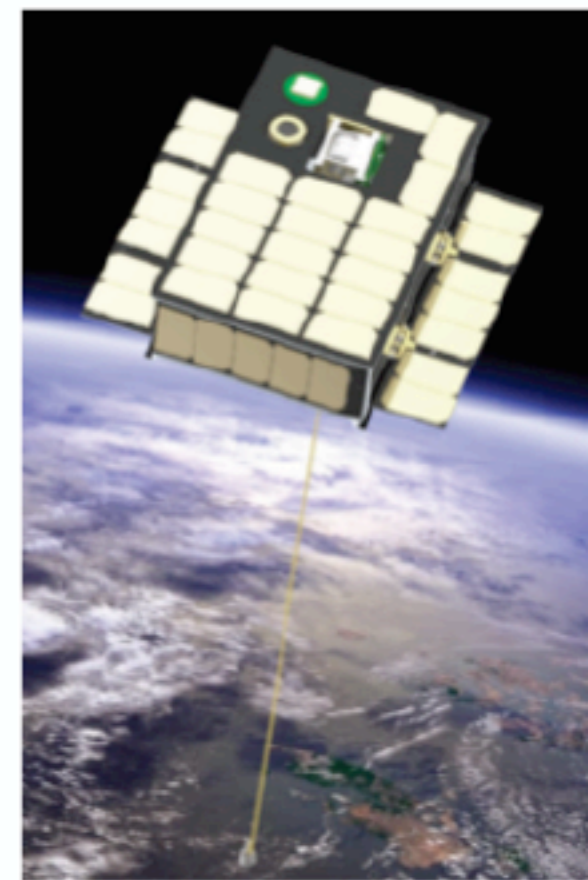

- BurstCube: a novel **6U CubeSat** that will **detect** and **localize** Gamma-ray Bursts (**GRBs**):
 - Focus on **short GRBs** (sGRBs; binary neutron star mergers) predicted to be the counterparts of gravitational wave (GW) sources.
- Will detect these with **four CsI** scintillators coupled with arrays of compact low-power **Silicon photomultipliers** (SiPMs).
- Spacecraft designed in-house (at WFF) using **off-the-shelf components** and a straightforward design and implementation.
- Complement to existing facilities (*Swift*, *Fermi*) and could be an **interim GRB instrument** before next generation missions fly.
- The ultimate configuration of BurstCube would be **a set of ~10 CubeSats** providing all-sky coverage for a very low cost.

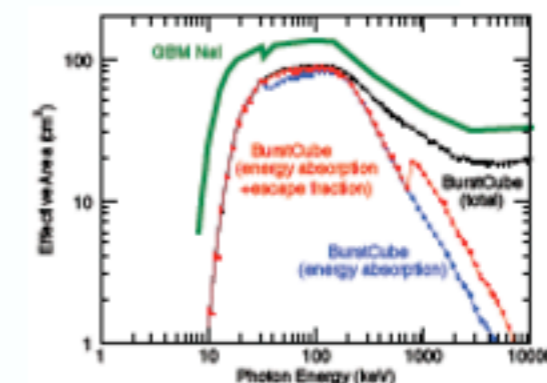
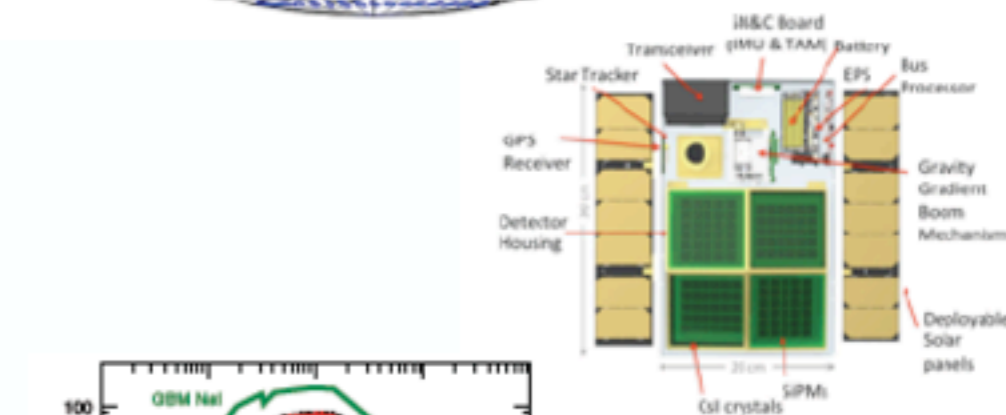
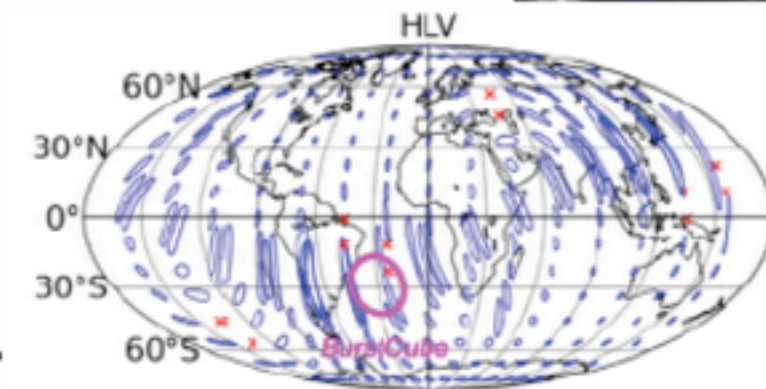

Finding NS-NS GRB Counterparts

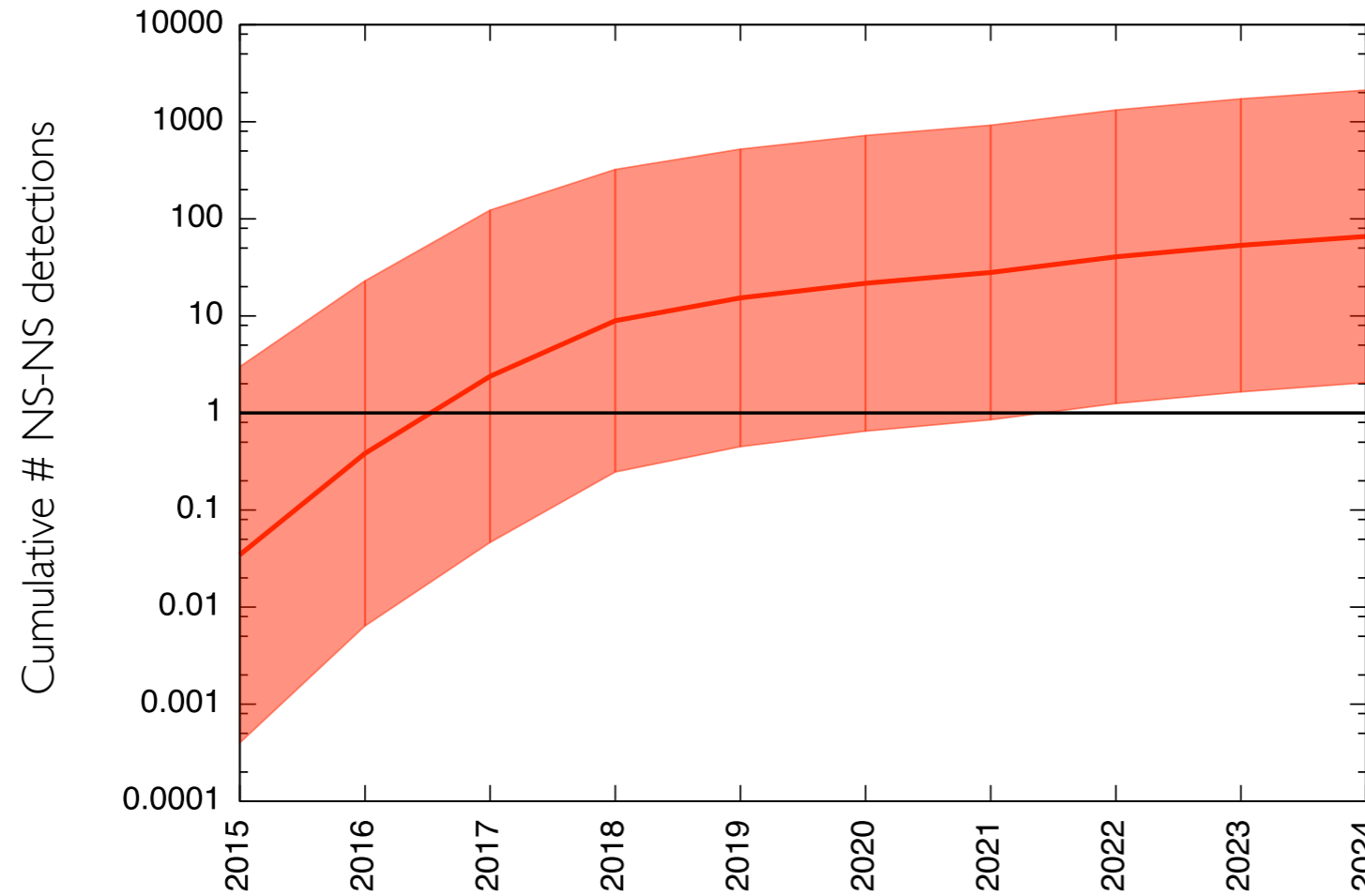

[LIGO-Virgo arXiv:1304.0670]

Coincidence rate estimation for AdV/aLIGO

Siellez et al arXiv:1405.2254

Missions	Swift	FERMI	SVOM
F.o.V.	1.4 sr	9.5 sr	2 sr
Energy band	15-150 keV	8 keV – 40 MeV	4 – 250 keV
Estimated rate (events yr ⁻¹)	0.11 ± 0.04	0.63 ± 0.21	0.14 ± 0.05

Rates versus sGRB beaming-angle (2017-18)

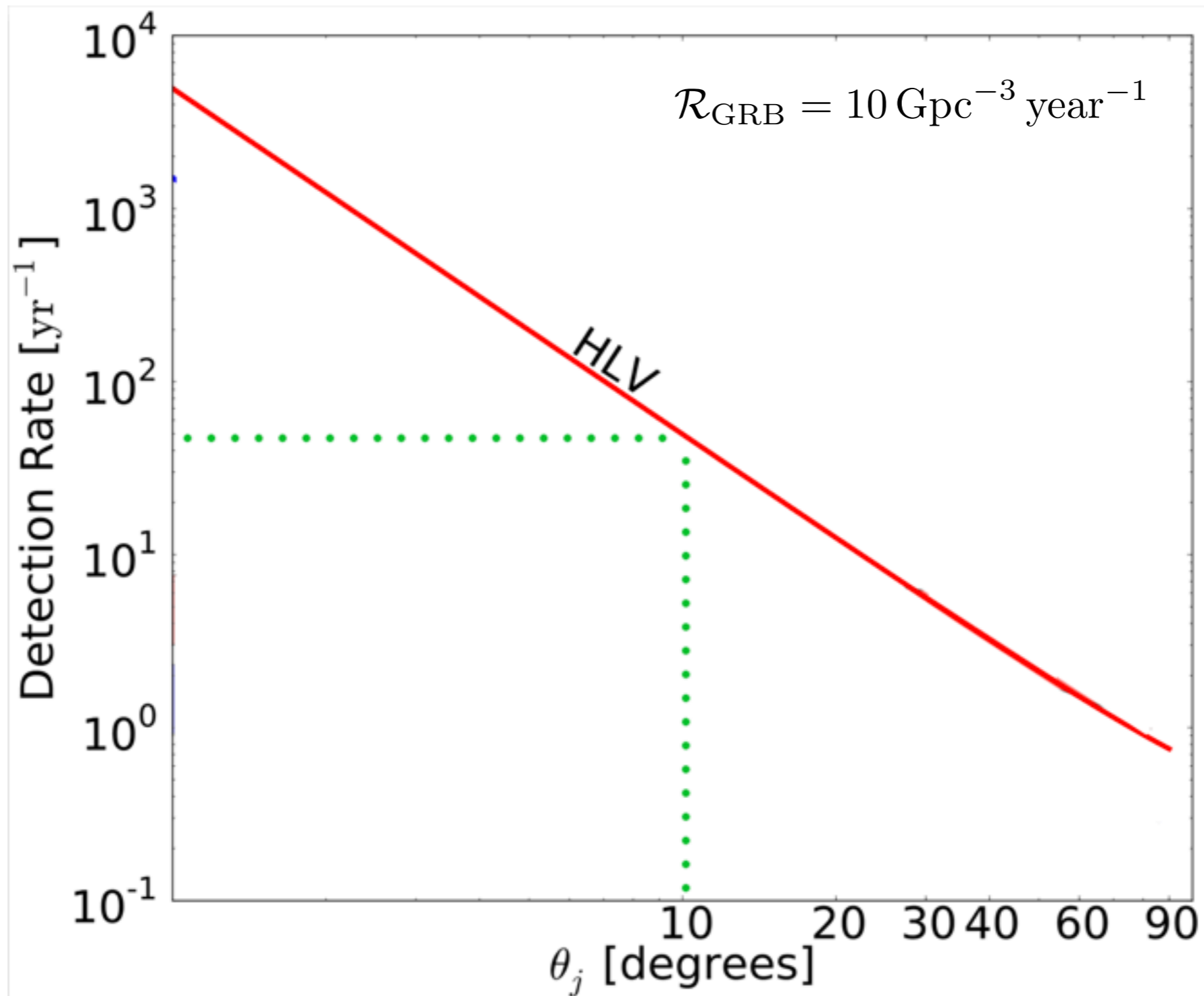

Chen & Holz (PRL 2012)

The only sure way to find counterparts to GW150914....

...fly LISA!

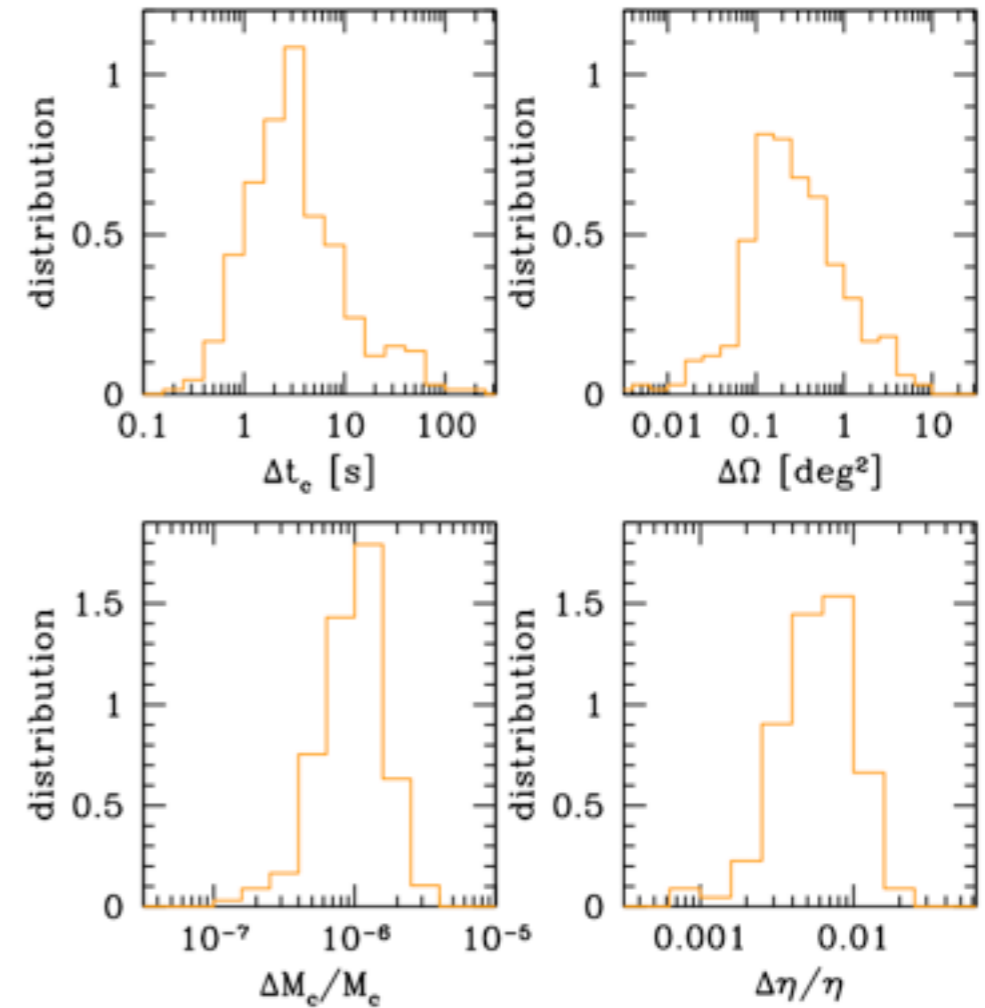
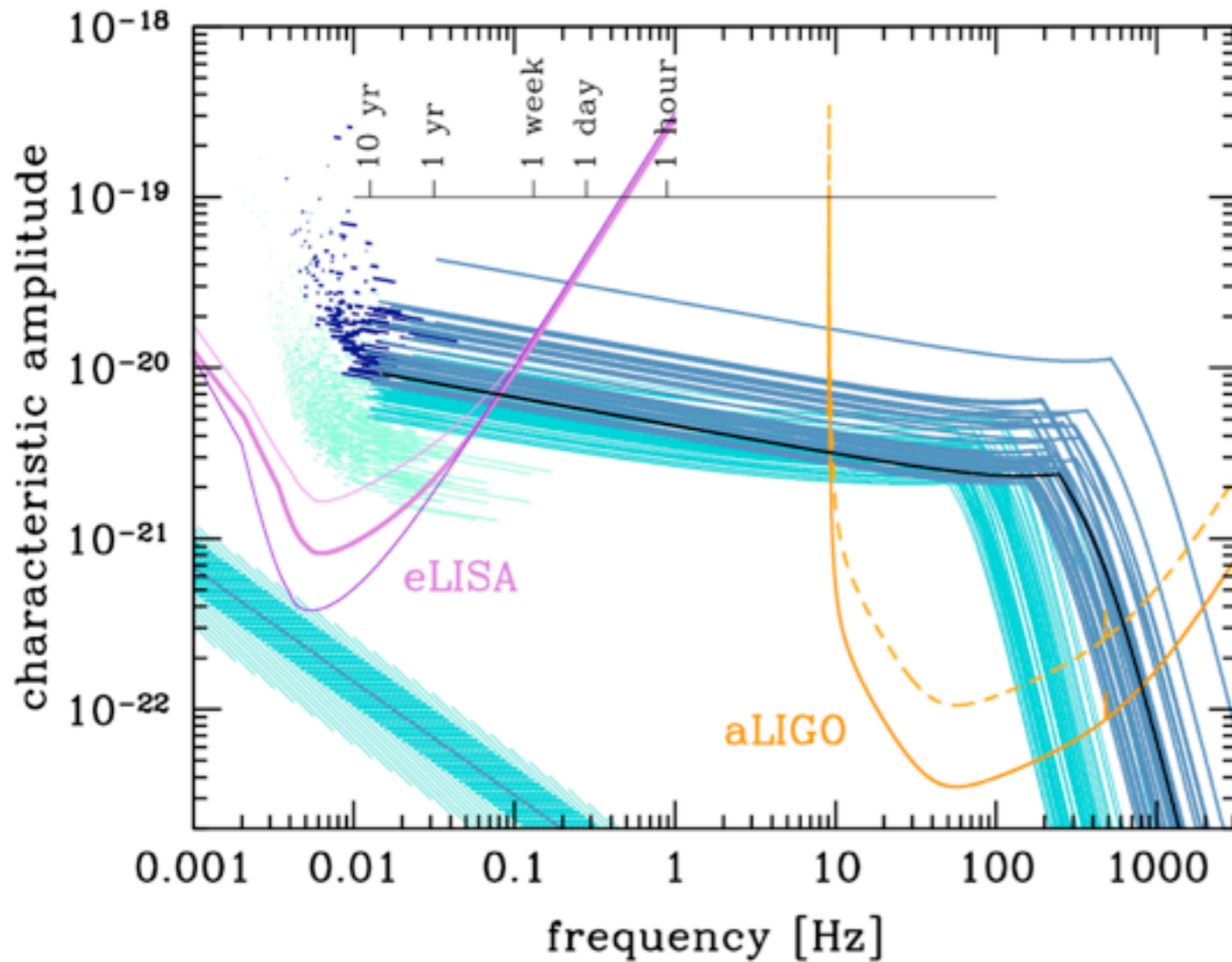

[A. Sesana arXiv: 1602.06951]

The only sure way to find counterparts to GW150914....

...fly LISA!

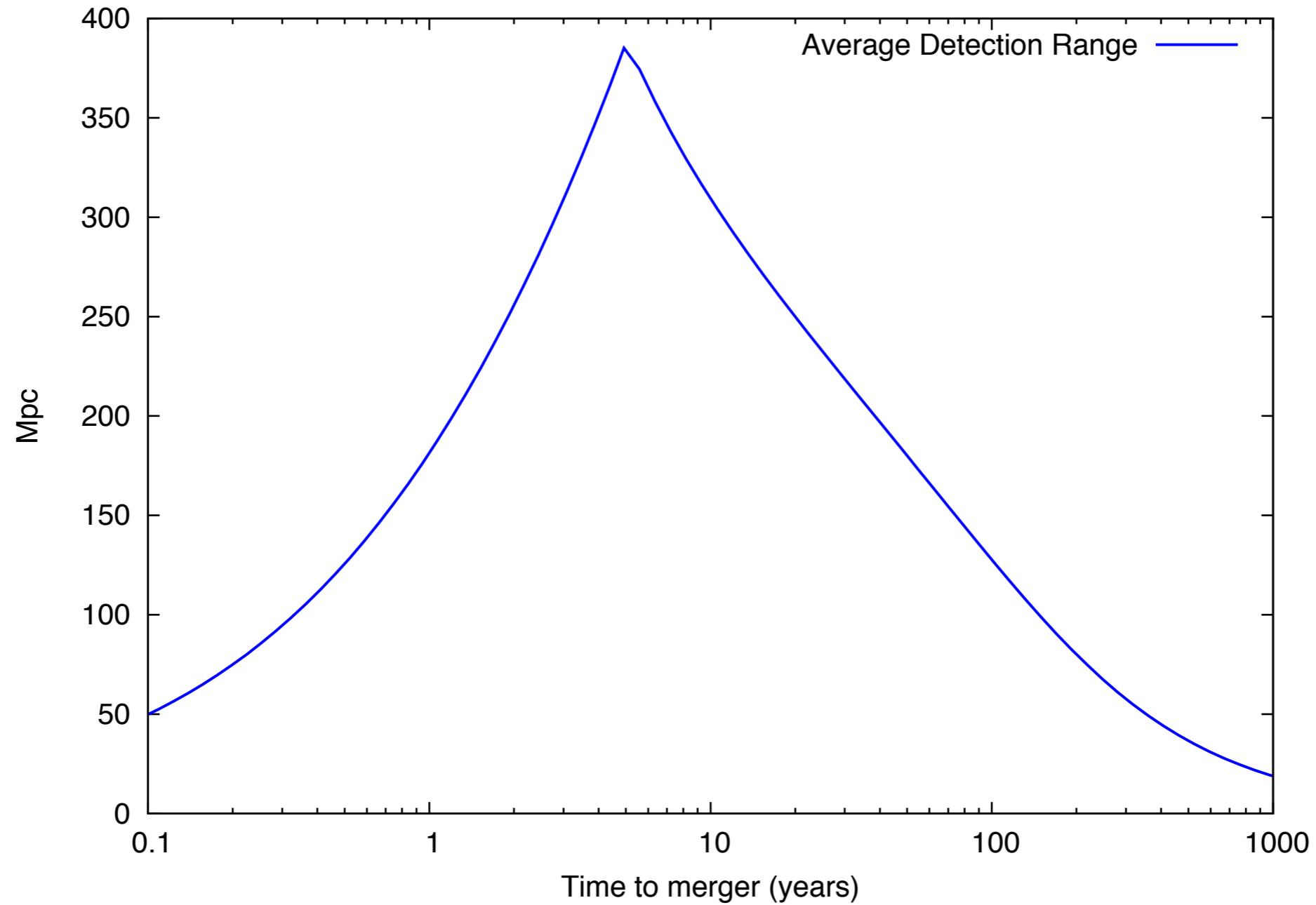

(assumes 5 year mission, 2 Gm, 6 links)

Conclusions

- Gravitational Wave Astronomy is here!
- Finding EM counterparts challenging but rewarding
- Assets may not be available during the prime 2020-2025 window for aLIGO
- Time to get serious about a space GW detector