

DETAIL A  
SCALE 2 : 1

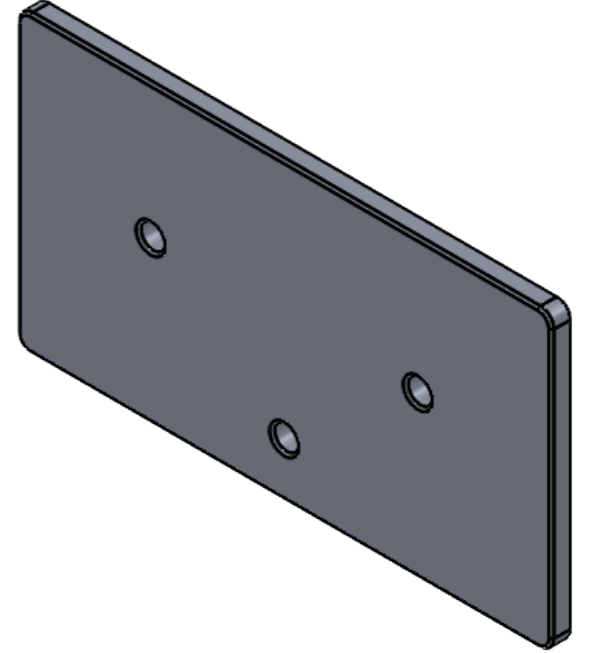
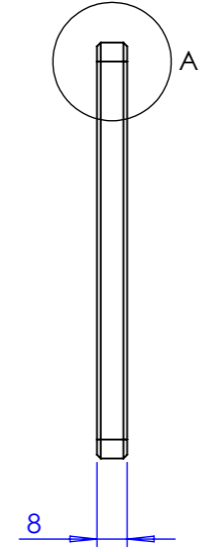

NOTES (UNLESS OTHERWISE SPECIFIED):		
DIMENSIONS ARE IN MILLIMETERS		
GENERAL TOLERANCES:		
0<X<50mm:	±0.1mm	
50<X<150mm:	±0.2mm	
150<X<1000mm:	±0.3mm	
ANGULAR:	±0.2°	
GEOMETRIC TOLERANCES:		
ISO-2768-K		
1. DEBUR AND BREAK SHARP EDGES		

DO NOT SCALE DRAWING		A3
GROUP:	Institute for Gravitational Research	
PROJECT:	CO2 Laser Pulling Machine	
SUB-SYSTEM:	--	
ASSEMBLY:	Spinning Mirror Assembly	
PART NAME:	Alignment Plate 1	
DRAWING NUMBER:	D1800133	REV: v1
SCALE: 1:2	PROJ: 3rd Angle	SHEET 1 OF 1